



 **CLAYTON**

STEAM MASTER

Clayton Industries' latest innovation, the small and highly efficient **Clayton STEAM MASTER**, has combined technical expertise and ease of use to deliver a superior product based on reliability and safety. It ushers in the next generation of superior products from Clayton Industries, a leader of steam boiler technology for more than 80 years.

SAVES FUEL | **SAVES SPACE** | **SAVES TIME** | **SAVES MONEY**

CLAYTON
STEAM MASTER

Clayton Steam Master

The Clayton Steam Master exemplifies the superior technological advancements of Clayton Industries' Research and Development Team and represents more than 80 years' experience engineering and building industrial steam boilers. Our newest product represents the next generation of Clayton Steam Generator and is rated for steam duties in the range up to 40 BHP/1400 PPH.

Technical Description

The Clayton Steam Master is available in three sizes that can be powered by either oil or gas. Gas-fired units have fully modulating output control from 100% to 20%. Oil-fired units are equipped with Clayton's three-step modulating controller. These units require only 220V single-phase electrical connection and typically consume less electricity than a domestic microwave oven.

The heart of the design is a heated once-through water tube coil that produces steam at an operating steam pressure of 100 psig. The Clayton Steam Master features Clayton's unique sealless and packless water pump that has been proven to give outstanding performance, response and reliability. Its durable construction is suitable for industrial environments and enables Clayton Industries to offer a five-year warranty* on materials and workmanship on pressure-related parts.

The Clayton Easy Start System offers a straight forward means of putting the unit into service. Its user-friendly touch screen presents immediate

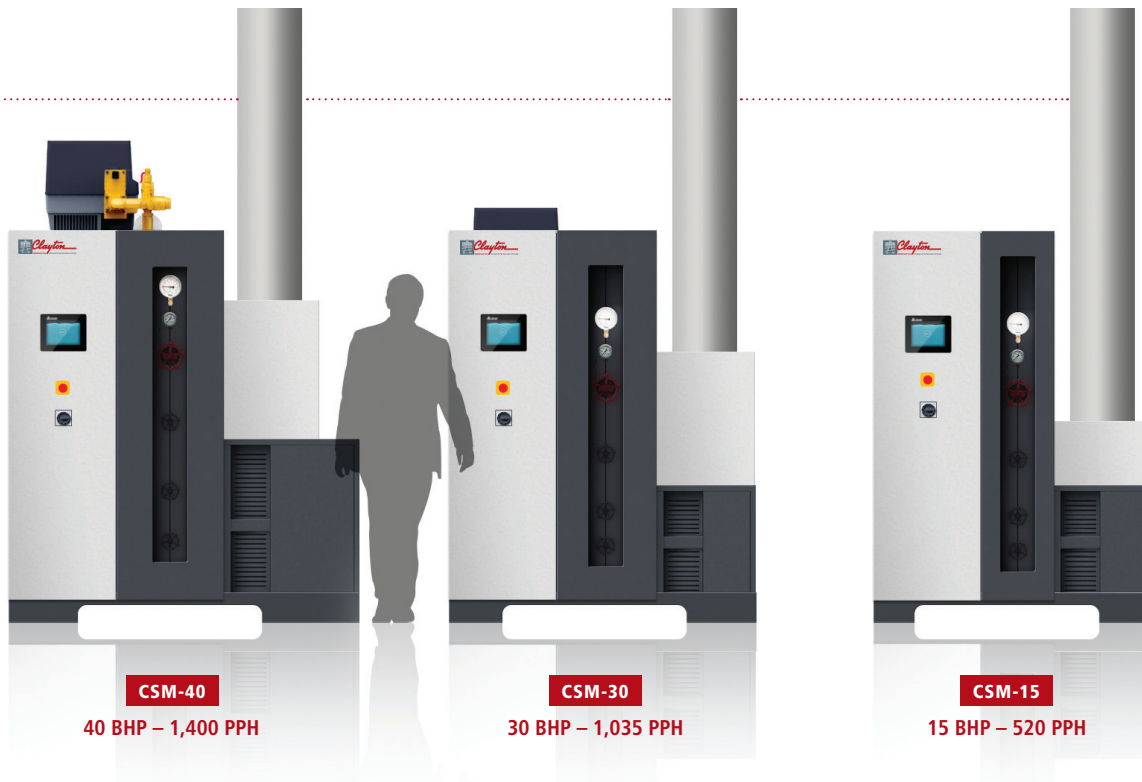

visual indication of status and prompts the operator with self-diagnostics. Information is clearly displayed to monitor your steam supply so you know it is functioning flawlessly.

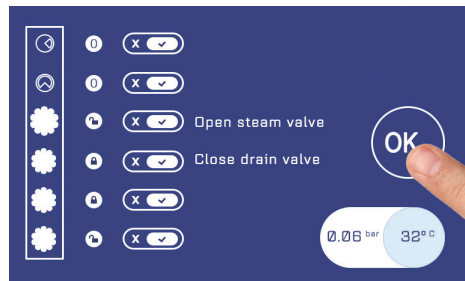

Approximate Overall Dimensions

	CSM-15	CSM-30	CSM-40
LENGTH	63"	71"	71"
WIDTH	46"	53"	53"
HEIGHT	67"	88"	98"

- Ease of Operation
- Touchscreen Control
- High Efficiency
- Five-Year Warranty*
- Full Modulation
- Low Emissions
- Safety
- Compact Size
- Short Start-up Time
- Reliability
- Low Maintenance
- Multiple/modular Boilers
- Complete Boiler Packages

Positioning of Water Treatment Package



POSITION 1

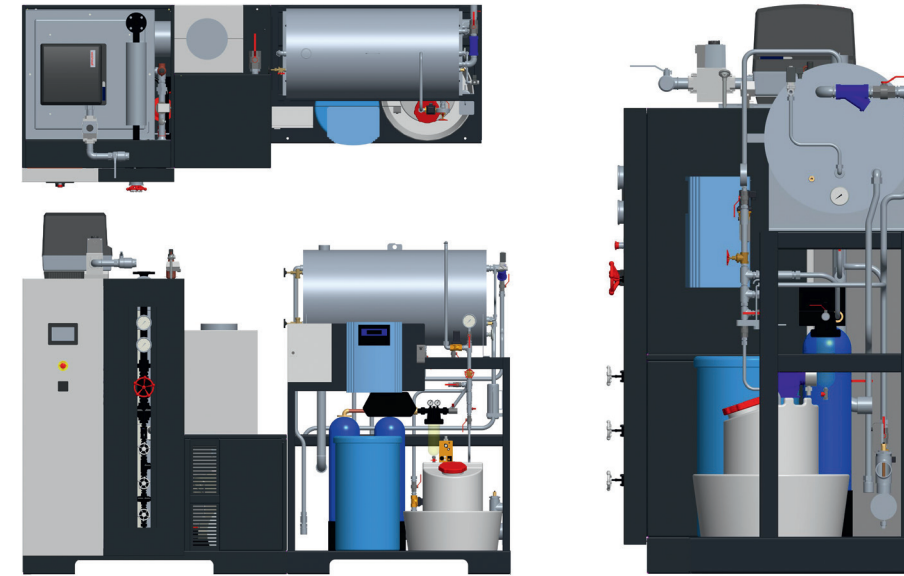

POSITION 2

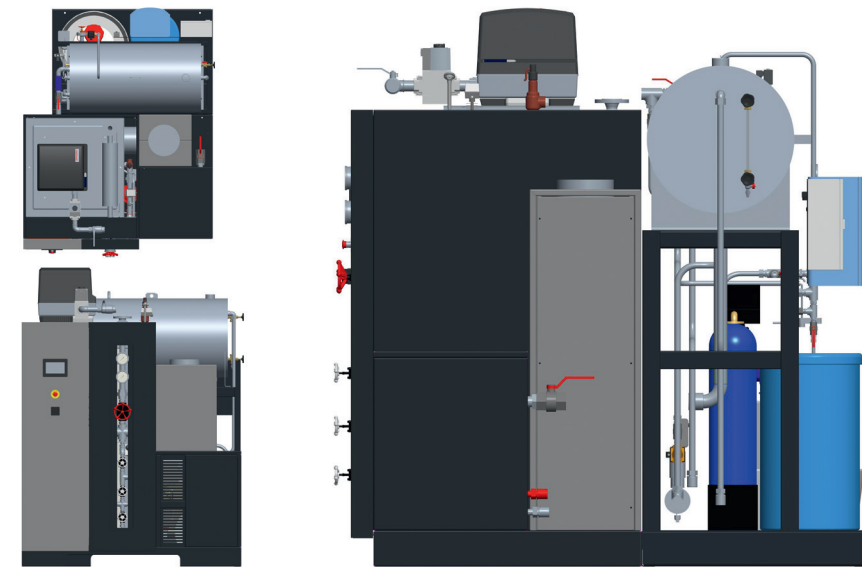

Option Packages

OPTION PACKAGES
Clayton Industries offers five packages to support configuration of the Clayton Steam Master to any specific application.

FUEL SAVING PACKAGE
Adding a finned-tube economizer section reduces fuel consumption and significantly lowers annual operating costs.

STEAM QUALITY PACKAGE
This package integrates a high-efficiency steam separator, steam trap and blowdown valve and can be supplied at initial product delivery or easily added after installation.

WATER TREATMENT PACKAGE
To help protect the boiler, this package adds a frame mounted and interconnected hotwell, chemical feed pump, blowdown tank, duplex water softener and sample cooler to be positioned next to and connected to the Clayton Steam Master.

REMOTE COMMUNICATION PACKAGE
For added peace of mind, have status messages sent to a mobile or Ethernet communication device for data exchange with a remote control system.

AUTOMATIC START/STOP PACKAGE
This package includes a backpressure regulator and uses a steam trap for unloading. It requires installation of the Steam Quality Package (above).

*Five-year limited warranty on pressure-related parts.

Advantages

The Clayton Steam Master's forced-circulation helical coil design produces outstanding benefits for the user.

HIGH EFFICIENCY

Very high efficiency is a benefit of its small size due to low radiation and convection heat losses and results in low running costs.

SMALL SIZE

Compact design means minimal space is required for a complete Clayton boiler house and its low weight allows for upper floor installation. In new constructions, building costs are reduced. In an existing application, a Clayton Steam Master system can be easily fitted into the available area. Its small size is also ideal for containerizing the perfect mobile boiler room.

RAPID START

The Clayton Steam Master will start up in five minutes from a completely cold condition. The warm-up fuel is minimized and the unit can be switched off when the operator leaves for the day, making it ideal for use in batch processes or as an auxiliary or standby boiler.

SAFETY

A steam explosion is not possible because the Clayton Steam Master does not store a large water volume.

5-YEAR WARRANTY

The Clayton Steam Master's extremely durable construction is suitable for industrial environments and enables Clayton Industries to offer a five-year limited warranty on materials and workmanship on its pressure-related parts.

RAPID RESPONSE

Extremely rapid response to changes in the demand for steam is inherent in the forced-circulation design. A Clayton Steam Master will quickly ramp up and run continuously at a stabilized maximum steam output.

LOW BLOWDOWN

The need for blowdown to prevent the buildup of impurities is greatly reduced in the Clayton Steam Master's design as compared to other boiler systems. This saves fuel, chemicals and water.

EASY OPERATION OF TOUCHSCREEN

Clayton Steam Master's touch screen panel is very easy to operate and displays operating instructions and manuals.

LOW MAINTENANCE

One practical benefit of the Steam Master's simple design is that it requires minimal maintenance. All of its components have been developed and improved over 85 years to make the Clayton Steam Master a reliable source of steam.

Clayton Industries' success is built on the reliability and expertise of our staff that is committed to providing exceptional levels of customer service and support. Clayton's lifetime customer care is second-to-none and our dedicated service team is ready to assist our clients at any time with immediate 24/7 technical support.

WORLDWIDE SALES & SERVICE SINCE 1930

Clayton Industries services the world with major manufacturing facilities in the USA, Europe, Latin America and Asia. Clayton direct sales and service offices and authorized distributors are located worldwide, offering around-the-clock customer support.

World Headquarters – USA

Tel: +1 (800) 423-4585
info@claytonindustries.com
www.claytonindustries.com

Canada

Tel: +1 (905) 791-3322
canada@claytonindustries.com
www.claytonindustries.com

Europe, Middle East, Africa Headquarters – Belgium

Tel: +32 (0)3 890 57 00
sales@clayton.be
www.clayton.be
www.clayton.fr
www.claytonindustries.co.uk
www.clayton-deutschland.de
www.clayton.es

Latin America Headquarters – Mexico

Tel: +52 (55) 55.86.51.00
sales@clayton.com.mx
www.clayton.com.mx

Asia Headquarters – China

Tel: +8621-62115832
asia@claytonindustries.com
www.claytonindustries.com

COIL →
 (FRONT DOOR OPEN)

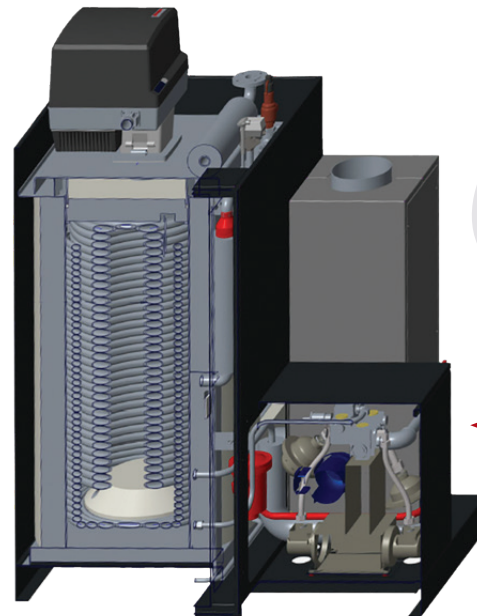

← **CLAYTON PUMP**
 (PANEL REMOVED)

