



---

## **MIRO BINDER**

---

COMPANY INFORMATION, DETAILED PRODUCT SPECIFICATIONS  
AND DATA, PRODUCT MAINTENANCE, WARRANTY, AND MORE

## Table of Contents

We are MIRO Industries.....	3
Terms and Conditions .....	4
List of Common MIRO Abbreviations .....	4
Warranty Card.....	5
Product Matrix – Naming Convention.....	6
MIRO Typical Base Specifications .....	8
Previous MIRO Model Names.....	9
Chart of Usual Pipe Sizes and Weights .....	10
Polycarbonate Resin Supply .....	11
Technical Properties For Polycarbonate Resin .....	12
General Installation and Maintenance.....	13
Pillow Block Supports.....	14
1.5 PILLOW BLOCK .....	15
3.0 PILLOW BLOCK.....	17
3-R-2 and 3-R-4.....	19
Roller Series Supports .....	22
3-RAH-8 and 3-RAH-12.....	23
4-RAH-10 and 4-RAH-14.....	26
4-RAH-8 SS and 4-RAH-12 SS .....	29
5-RAH-8 and 5-RAH-12.....	32
6-RAH-8, 6-RAH-12.....	35
6-RAH-8 SS and 6-RAH-12 SS .....	38
10-RAH-8 and 10-RAH-18.....	41
Strut Supports .....	44
8-Base Strut-2, 8-Base Strut-5, 8-Base Strut-8, 8-Base Strut-12.....	45
8-Base Strut-8 SS and 8-Base Strut-12 SS .....	50
12-Base Strut-8 and 12-Base Strut-12.....	53
12-Base Strut-8 SS and 12-Base Strut-12 SS .....	56
16-Base Strut-8 and 16-Base Strut-12.....	59
20-Base Strut-4, 20-Base Strut-8, and 20-Base Strut-18.....	62
24-Base Strut-5, 36-Base Strut-5, and 48-Base Strut-5.....	66
Custom Hanger Supports.....	70
6H (P), 6H (HDG) and 6H (SS).....	71
8H (P), 8H (HDG) and 8H (SS).....	74
10H (P)    77	
Custom Duct Supports .....	79
6DS (P), 6DS (HDG) and 6DS (SS).....	80
8DS (P), 8DS (HDG) and 8DS (SS).....	83

10DS (P) 86	
GENERAL INSTALLATION OF CUSTOM HANGER AND DUCT SUPPORT MODELS .....	88
INSTALACIÓN GENERAL DE LA PERCHA PERSONALIZADA Y MODELOS DE DE CONDUCTOS .....	89
CUSTOM SUPPORT SLOPE AND ADJUSTMENT .....	90
Mechanical Supports.....	91
LD MECHANICAL UNIT SUPPORTS.....	92
HD MECHANICAL UNIT SUPPORTS .....	97
Surefoot Access .....	101
SUREFOOT ACCESS BRIDGE CROSSOVERS .....	102
SUREFOOT ACCESS SERVICE PLATFORMS.....	104
SUREFOOT ACCESS RAMP.....	106
SUREFOOT ACCESS WALKWAYS .....	108
Wind and Seismic .....	110
SEISMIC & WIND COMPLIANT SYSTEMS .....	111
Accessories.....	117
SUPPORT PADS.....	118
1.5 SPACER.....	120
3-R SPACER .....	122
ROLLER 3 AND ROLLER 5.....	124
3-R Bracket.....	126
PIPE GUIDES.....	128
Custom Product Pricing .....	131
SECTION 07 70 00 ROOFTOP ACCESSORIES.....	132
Part 2    GENERAL .....	132
Part 2    PRODUCTS .....	135
Part 3    EXECUTION .....	159

## **WE ARE MIRO INDUSTRIES**

Mike (MI) and Rosy (RO) Neider formed MIRO Industries, Inc. with the help of their daughters in 1982 by taking the original version of the 1.5 Pillow Block rooftop support to market through distribution. Their daughter, Nicole, maintained the company into her college days where she met and married Nathan Sargent. Nicole and Nathan, seeing the potential with the product and services, have grown it to what it is today with the help of many dedicated and loyal friends and associates.

MIRO's mission statement is:

**“Produce superior rooftop support products while maintaining an elite focus on providing exceptional customer service as a turn-key solution to every customer.”**

MIRO Industries is a recognized leader in the rooftop support industry for providing solutions to meet the needs of contractors, consultants, engineers and architects. MIRO's mission is accomplished through its dedicated staff which pushes daily to exceed expectations. MIRO Industries, Inc. exists to find solutions to your specific rooftop support needs. MIRO is committed and highly motivated to assist you from preliminary budgeting and design through product delivery, installation and throughout the life of the facility. As we develop and invest in each of our relationships, we look forward to supporting you.

The roof of a building is one of its most important elements, and its integrity must be maintained regardless of the equipment placed on the roof. Whether used with new construction, a remodel or retrofit project, MIRO Industries Rooftop Supports are designed to distribute loads over the maximum appropriate surface area, reducing unwanted roof penetrations where possible. MIRO Industries selects the right materials to help mitigate other types of potential damage including UV degradation, corrosion and negative chemical interactions.

Whether supporting roof pipes conveying gas or liquid content, electrical conduit, solar piping, or other mechanical piping, HVAC equipment, valves, control boxes, or communication equipment, MIRO Rooftop Support Products offer both off-the-shelf and custom solutions, to meet and exceed your expectations.

Access to rooftop equipment is also an area of expertise for MIRO. Requirements in building codes, as well as OSHA requirements for working walking surfaces, are addressed with MIRO Industries Surefoot Access products. Surefoot access includes bridge or crossover structures to gain access from one roof level to another, or to navigate rooftops without needing to duck under or crawl over existing rooftop equipment or distribution lines. A variety of options can be used from our typical stair assemblies to ramps, ships ladders or vertical ladders where appropriate. Additionally, walkways and service platforms provide a level and safe working environment for maintenance personnel.

MIRO is your one-stop source for rooftop supports and access from planning through completion. MIRO's goal is your complete satisfaction with provided products and services. MIRO employs a ready-to-work staff that maximizes the value of your investment. Services provided include; Consulting, On-Site Takeoffs, Installation, and Maintenance Programs.



## TERMS AND CONDITIONS

MIRO Industries, Inc. ("MIRO") conducts all sales transactions in accordance with its Standard Sales Terms and Conditions available at [www.miroind.com/terms-conditions](http://www.miroind.com/terms-conditions).

### LIST OF COMMON MIRO ABBREVIATIONS

- R - Roller
- RAH – Roller Adjustable Height
- BS – Base Strut
- H – Hanger
- DS – Duct Support
- HD – Heavy Duty
- CO - Crossover
- P – Polycarbonate Composite
- SS – Stainless-steel
- HDG – Hot-dip Galvanized
- H.O.R. – Height off Roof
- ID – Inside Diameter
- OD – Outside Diameter
- C – Clevis Hanger
- BH – Band Hanger
- RH – Roller Hanger
- RC – Roller Chair
- T – Trapeze
- psi – pounds per square inch

**MIRO INDUSTRIES, INC.**  
**WARRANTY CARD**

1. Owner Name and Address:  
 \_\_\_\_\_  
 \_\_\_\_\_  
 \_\_\_\_\_

2. Building Address:  
 \_\_\_\_\_  
 \_\_\_\_\_  
 \_\_\_\_\_

3. Date of Purchase and MIRO invoice number:  
 \_\_\_\_\_

4. Distributor Name:  
 \_\_\_\_\_

5. Contractor Name:  
 \_\_\_\_\_

6. Date of Installation:  
 \_\_\_\_\_

7. Number and Model of MIRO supports installed:  
 \_\_\_\_\_  
 \_\_\_\_\_  
 \_\_\_\_\_

8. MIRO Representative:  
 \_\_\_\_\_

I attest that I have read the installation and specifications for MIRO products and installed the supports as directed using only MIRO products.

\_\_\_\_\_  
 Authorized Signature of Installer/Contractor

**LIMITED WARRANTY**

MIRO Industries, Inc. ("MIRO") warrants to owner of the building on which the MIRO products identified above are installed, that such products, at the time of installation, substantially conform to the Specification Sheets, Shop Drawings, and/or Professional Engineer's Drawings (whichever the case may be) attached hereto as Exhibit A, and that such products shall be free from defects in material and workmanship from the date of installation through the period of time specified in the Warranty Coverage Tables below if properly used and inspected in accordance with MIRO's instructions and/or recommendations. MIRO makes NO WARRANTY concerning components or accessories not manufactured by MIRO that may have been incorporated but will pass on to the purchaser all manufacturer warranties of such components to the extent that such warranties exist, if at

all. This warranty does not cover Acts of God, vandalism, neglect, improper use, or faulty installation. THE WARRANTIES SET FORTH HEREIN ARE MADE IN LIEU OF ALL OTHER WARRANTIES, EXPRESS, IMPLIED, OR STATUTORY, INCLUDING THE IMPLIED WARRANTY OF FITNESS FOR A PARTICULAR PURPOSE.

- To maintain this warranty, the building owner or its agent must:
1. Arrange for the MIRO products identified above to be inspected at least annually to check proper alignment and tighten all nuts and bolts appropriately; and
  2. Keep a log of such maintenance.

MIRO shall be immediately released from all obligations under this warranty in the event any of the above requirements have not been fully satisfied or if the MIRO products identified above, or any components related thereto:

1. Have been used inconsistent with MIRO's instructions or its intended use; or
2. Have been modified or repaired by anyone other than MIRO; or
3. Have been damaged because of misuse or neglect.

**CLAIMS AND LIMITED REMEDIES:** Claims must be submitted in writing within thirty (30) days of observance of any potential defects to MIRO Industries, Inc., 844 South 430 West, Heber City, UT 84032. The Limited Warranty holder must permit MIRO or its agents to inspect any potential defect and must provide MIRO or its agents with any installation reports, maintenance logs, or other documentation with respect to any claim under the Limited Warranty. If MIRO, in its sole discretion, approves a claim covered under the Limited Warranty, MIRO's sole obligation will be to repair or replace defective items with items of comparable value to the extent commercially reasonable. THE FOREGOING WILL CONSTITUTE THE EXCLUSIVE REMEDY FOR THE LIMITED WARRANTY. LIABILITY OF MIRO IS LIMITED TO THE ABOVE, AND IN NO EVENT WILL MIRO BE LIABLE FOR ANY INDIRECT, INCIDENTAL, SPECIAL OR CONSEQUENTIAL DAMAGES, INCLUDING WITHOUT LIMITATION ECONOMIC, LOSS OF PROFITS, OR OTHER DAMAGES OF ANY KIND WHATSOEVER. This provision is applicable to claims for breach of warranty, tortious conduct, or any other cause of action asserted against MIRO.

**LIMITATIONS.** This warranty is expressly given to the owner of the building on which MIRO products identified are installed and may not be transferred or assigned to any other person or entity without prior written consent from MIRO.

**WARRANTY COVERAGE TABLES**

Item Description	Length of Warranty
MIRO brand Products	20 years
ROOFTOP SLEEPER SUPPORT brand Products	2 years
UNIFLEX brand base only Products	1 year

**MIRO Industries, Inc.**

\_\_\_\_\_  
 Signature

\_\_\_\_\_  
 Title

\_\_\_\_\_  
 Date

## PRODUCT MATRIX – NAMING CONVENTION

The product matrix table below provides information for a quick reference to the Roller, Strut, and Custom series supports. Cross reference the Index on pages 1 and 2 for the page number of the pipe support that fits your needs. Still have questions? Call us at 1-800-768-6978 or email at [sales@miroind.com](mailto:sales@miroind.com).

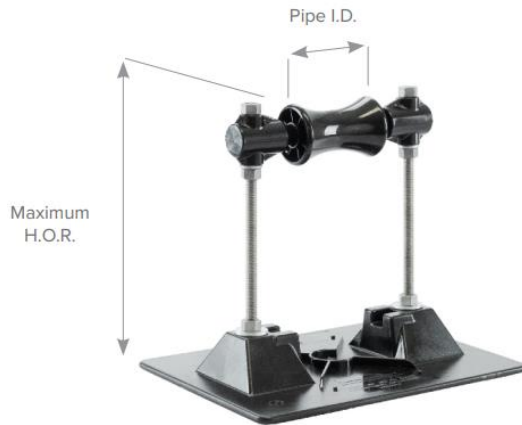

### ROLLER SERIES

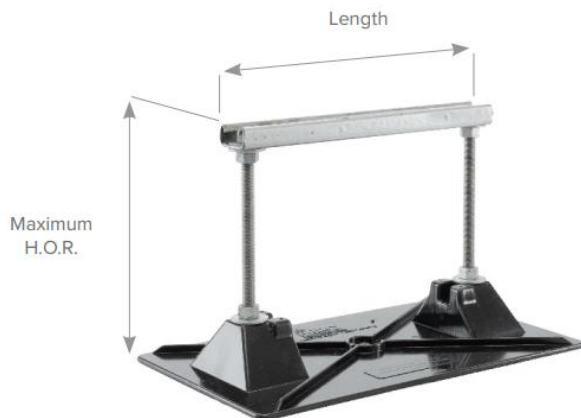

### STRUT SERIES

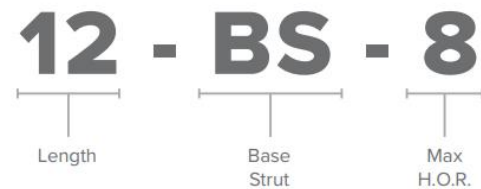

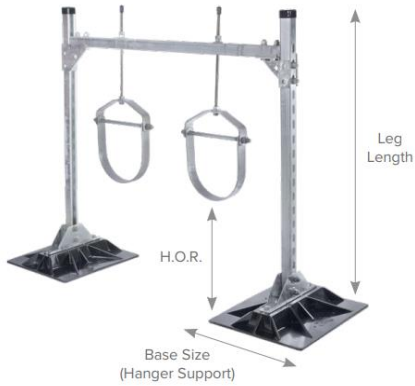

**WATER AND STEAM**

**8H - 2C36 P-20 W/(2)6" CLEVIS**



**DUCT AND CABLE TRAYS**

**8DS 36X58 P-14**



**HD MECHANICAL SUPPORT**

**8HD 36X48 SB-12**

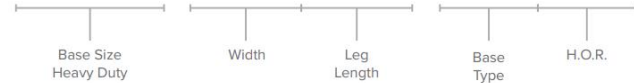

## MIRO TYPICAL BASE SPECIFICATIONS

Model Name	Base Dimensions (Inches)	Base Material	Roof Contact Area (Square Inches)	Allowable load at 3.0 psi (Pounds)
<b>PILLOW BLOCK SUPPORTS</b>				
1.5 Pillow Block	6 x 6	Polycarbonate	24.42	72
1.5 Spacer	6 x 6	Polycarbonate	31.78	72
3-R-2 Pillow Block	7-3/4 x 7-3/4	Polycarbonate	39.64	118
3-R-4 Pillow Block	7-3/4 x 7-3/4	Polycarbonate	39.64	118
3-R Spacer	7-3/4 x 7-3/4	Polycarbonate	39.64	118
<b>ROLLER SUPPORTS</b>				
3-RAH-8	7-1/2 x 10	Polycarbonate	57.5	172
3-RAH-12	7-1/2 x 10	Polycarbonate	57.5	172
4-RAH-10	9 x 15-1/4	Polycarbonate	111.75	335
4-RAH-14	9 x 15-1/4	Polycarbonate	111.75	186 <sup>(1)</sup>
5-RAH-8	9 x 15-1/4	Polycarbonate	111.75	335
5-RAH-12	9 x 15-1/4	Polycarbonate	111.75	335
6-RAH-8	16 x 18	Polycarbonate	192.89	578
6-RAH-12	16 x 18	Polycarbonate	192.89	578
10-RAH-8	19 x 23	Polycarbonate	320	960
10-RAH-18	19 x 23	Polycarbonate	320	803 <sup>(1)</sup>
4-RAH-8 SS	12 x 16	Stainless Steel	174.89	419 <sup>(1)</sup>
4-RAH-12 SS	12 x 16	Stainless Steel	174.89	186 <sup>(1)</sup>
6-RAH-8 SS	12 x 16	Stainless Steel	174.89	524
6-RAH-12 SS	12 x 16	Stainless Steel	174.89	524
<b>STRUT SUPPORTS</b>				
8-BASE STRUT-2	7-1/2 x 10	Polycarbonate	57.5	172
8-BASE STRUT-5	7-1/2 x 10	Polycarbonate	57.5	172
8-BASE STRUT-8	7-1/2 x 10	Polycarbonate	57.5	172
8-BASE STRUT-12	7-1/2 x 10	Polycarbonate	57.5	172
12-BASE STRUT-8	9 x 15-1/4	Polycarbonate	111.75	335
12-BASE STRUT-12	9 x 15-1/4	Polycarbonate	111.75	335
16-BASE STRUT-8	16 x 18	Polycarbonate	192.89	578
16-BASE STRUT-12	16 x 18	Polycarbonate	192.89	578
20-BASE STRUT-4	19 x 23	Polycarbonate	320	960
20-BASE STRUT-8	19 x 23	Polycarbonate	320	960
20-BASE STRUT-18	19 x 23	Polycarbonate	320	960
24-BASE STRUT-5	(2) 7-1/2 x 10	Polycarbonate	57.5	172 <sup>(2)</sup>
36-BASE STRUT-5	(3) 7-1/2 x 10	Polycarbonate	57.5	172 <sup>(2)</sup>
48-BASE STRUT-5	(4) 7-1/2 x 10	Polycarbonate	57.5	172 <sup>(2)</sup>
8-BASE STRUT-8 SS	12 x 16	Stainless Steel	174.89	419 <sup>(1)</sup>
8-BASE STRUT-12 SS	12 x 16	Stainless Steel	174.89	186 <sup>(1)</sup>
12-BASE STRUT-8 SS	12 x 16	Stainless Steel	174.89	524
12-BASE STRUT-12 SS	12 x 16	Stainless Steel	174.89	524
<b>CUSTOM HANGER SUPPORTS</b>				
6-H	9 x 15-1/4	Polycarbonate	111.75	335 <sup>(3)</sup>
6-H HDG / SS	8 x 14	HDG / SS	96.06	288 <sup>(3)</sup>
8-H	16 x 18	Polycarbonate	192.89	578 <sup>(3)</sup>
8-H HDG / SS	12 x 16	HDG / SS	174.89	524 <sup>(3)</sup>
10-H	19 x 23	Polycarbonate	320	960 <sup>(3)</sup>
16-H	(2) 16 x 18	Polycarbonate	(2) @ 192.89	1156 <sup>(3)</sup>
<b>CUSTOM DUCT SUPPORTS</b>				
6-DS	9 x 15-1/4	Polycarbonate	111.75	335 <sup>(3)</sup>
6-DS HDG / SS	8 x 14	HDG / SS	96.06	288 <sup>(3)</sup>
8-DS	16 x 18	Polycarbonate	192.89	578 <sup>(3)</sup>
8-DS HDG / SS	12 x 16	HDG / SS	174.89	524 <sup>(3)</sup>
10-DS	19 x 23	Polycarbonate	320	960 <sup>(3)</sup>

HDG - Hot Dip Galvanized    SS - Stainless Steel

- (1) Allowable loading controlled by the capacity of the vertical all-thread members.  
 (2) Assumes uniformly distributed or symmetrical loading on the vertical header bar.  
 (3) Assumes uniformly distributed or symmetrical loading on the vertical header bar. Frame must also be checked for bending and deflection limit states which may decrease the frame capacity depending on loading.



## PREVIOUS MIRO MODEL NAMES

1999 NAME	2000 NAME	2006 NAME	2019 NAME
02	1.5	1.5	1.5
24-R	3-R	3-R-2	3-R-2
25-R	4-R	<i>Discontinued</i> See 4-RAH supports	<i>Discontinued</i> See 4-RAH supports
-	-	3-RAH-7	3-RAH-8
24-RAH and 25-RAH	4-RAH	4-RAH-7	4-RAH-10
-	-	4-RAH-12	4-RAH-14
48-R2	8-R2	<i>Discontinued</i> See 5-RAH supports	<i>Discontinued</i> See 5-RAH supports
48-R6	8-R6	5-RAH-7	5-RAH-8
59-RAH	5-RAH	5-RAH-7	5-RAH-8
48-RAH	6-RAH	6-RAH-7	6-RAH-8
48-R12	8-R12	6-RAH-7	6-RAH-8
59-R	5-R	<i>Discontinued</i> See 5-RAH supports	<i>Discontinued</i> See 5-RAH supports
-	-	8-RAH-18	10-RAH-18
-	2.5 Conduit Support	2.5-CS-2	8-BS-2
-	-	2.5-CS-5	8-BS-5
-	2.5 Conduit-AH	2.5-CS-7	8-BS-8
-	-	2.5-CS-12	8-BS-12
-	-	16-BS-7	12-BS-8
-	-	16-BS-12	12-BS-12
-	-	20-BS-7	16-BS-8
-	-	20-BS-12	16-BS-12
-	-	24-BS-4	20-BS-4
-	-	24-BS-18	20-BS-18

## CHART OF USUAL PIPE SIZES AND WEIGHTS

Trade Size (in)	STEEL PIPE							
	Sch. 40				Sch. 80			
	ID (in)	OD (in)	Empty (lb/ft)	*Full (lb/ft)	ID (in)	OD (in)	Empty (lb/ft)	*Full (lb/ft)
0.5	0.62	0.84	0.85	0.98	0.55	0.84	1.09	1.19
0.75	0.82	1.05	1.13	1.36	0.74	1.05	1.48	1.66
1	1.05	1.32	1.68	2.06	0.96	1.32	2.17	2.49
1.25	1.38	1.66	2.27	2.92	1.28	1.66	3.00	3.56
1.5	1.61	1.90	2.72	3.60	1.50	1.90	3.63	4.40
2	2.07	2.38	3.66	5.11	1.94	2.38	5.03	6.31
2.5	2.47	2.88	5.80	7.87	2.32	2.88	7.67	9.51
3	3.07	3.50	7.58	10.79	2.90	3.50	10.26	13.13
3.5	3.55	4.00	9.12	13.40	3.36	4.00	12.52	16.37
4	4.03	4.50	10.80	16.32	3.83	4.50	15.00	19.98
5	5.05	5.56	14.63	23.30	4.81	5.56	20.80	28.69
6	6.07	6.63	18.99	31.52	5.76	6.63	28.60	39.90
8	7.98	8.63	28.58	50.27	7.63	8.63	43.43	63.23
10	10.02	10.75	40.52	74.71	9.56	10.75	64.39	95.53
12	11.94	12.75	53.57	102.10	11.38	12.75	88.59	132.66

Trade Size (in)	STAINLESS STEEL PIPE							
	Sch. 40s				Sch. 80s			
	ID (in)	OD (in)	Empty (lb/ft)	*Full (lb/ft)	ID (in)	OD (in)	Empty (lb/ft)	*Full (lb/ft)
0.5	0.62	0.84	0.87	1.00	0.55	0.84	1.1	1.20
0.75	0.82	1.05	1.2	1.43	0.74	1.05	1.5	1.69
1	1.05	1.32	1.7	2.07	0.96	1.32	2.2	2.51
1.25	1.38	1.66	2.3	2.95	1.28	1.66	3.1	3.66
1.5	1.61	1.90	2.8	3.68	1.50	1.90	3.7	4.47
2	2.07	2.38	3.7	5.15	1.94	2.38	5.1	6.38
2.5	2.47	2.88	5.9	7.97	2.32	2.88	7.8	9.64
3	3.07	3.50	7.8	11.00	2.90	3.50	10.5	13.36
3.5	3.55	4.00	9.3	13.58	3.36	4.00	12.8	16.65
4	4.03	4.50	11	16.52	3.83	4.50	15.3	20.28
5	5.05	5.56	15	23.67	4.81	5.56	21.3	29.18
6	6.07	6.63	19.4	31.92	5.76	6.63	29.2	40.50
8	7.98	8.63	29.2	50.88	7.63	8.63	44.4	64.19
10	10.02	10.75	41.4	75.57	9.75	10.75	56	88.35
12	12.00	12.75	50.7	99.71	11.75	12.75	67	113.99

Trade Size (in)	PVC PIPE							
	Sch. 40				Sch. 80			
	ID (in)	OD (in)	Empty (lb/ft)	*Full (lb/ft)	ID (in)	OD (in)	Empty (lb/ft)	*Full (lb/ft)
0.5	0.62	0.84	0.16	0.29	0.55	0.84	0.20	0.30
0.75	0.82	1.05	0.21	0.44	0.74	1.05	0.27	0.46
1	1.05	1.32	0.32	0.69	0.96	1.32	0.41	0.72
1.25	1.38	1.66	0.43	1.08	1.28	1.66	0.52	1.08
1.5	1.61	1.90	0.51	1.39	1.50	1.90	0.67	1.44
2	2.07	2.38	0.68	2.13	1.94	2.38	0.95	2.23
2.5	2.47	2.88	1.07	3.15	2.32	2.88	1.45	3.29
3	3.07	3.50	1.41	4.61	2.90	3.50	1.94	4.80
3.5	--	--	--	--	--	--	--	--
4	4.03	4.50	2.01	7.53	3.83	4.50	2.75	7.73
5	5.05	5.56	2.73	11.40	4.81	5.56	3.87	11.76
6	6.07	6.63	3.53	16.06	5.76	6.63	5.42	16.72
8	7.98	8.63	5.39	27.08	7.63	8.63	8.05	27.85
10	10.02	10.75	7.55	41.74	9.56	10.75	12.00	43.15
12	11.94	12.75	10.01	58.54	11.38	12.75	16.50	60.57

Trade Size (in)	CONDUIT							
	Rigid Steel Conduit (RSC)				Inter. Metal Conduit (IMC)			
	ID (in)	OD (in)	Empty (lb/ft)	Full (lb/ft)	ID (in)	OD (in)	Empty (lb/ft)	*Full (lb/ft)
0.5	0.63	0.84	0.82	0.96	0.68	0.82	0.07	0.22
0.75	--	--	--	--	0.88	1.03	0.92	1.18
1	1.06	1.32	1.61	1.99	1.12	1.29	1.20	1.63
1.25	1.39	1.66	2.18	2.84	1.47	1.64	1.53	2.26
1.5	1.62	1.90	2.63	3.53	1.70	1.88	1.88	2.87
2	2.08	2.38	3.50	4.98	2.17	2.36	2.51	4.11
2.5	2.49	2.88	5.59	7.70	2.60	2.86	4.22	6.52
3	3.09	3.50	7.27	10.52	3.22	3.48	5.20	8.72
3.5	3.57	4.00	8.80	13.14	3.71	3.97	6.05	10.74
4	4.05	4.50	10.30	15.89	4.21	4.47	6.74	12.76
5	5.07	5.56	14.00	22.76	--	--	--	--
6	6.09	6.63	18.40	31.04	--	--	--	--
8	--	--	--	--	--	--	--	--
10	--	--	--	--	--	--	--	--
12	--	--	--	--	--	--	--	--

## **POLYCARBONATE RESIN SUPPLY**



August 24, 2016

2700 South 900 West Suite D  
Salt Lake City, Utah  
84119

TEL 801.355.2705  
FAX 801.355.3045  
www.biomerics.com

Miro Industries

844 South 430 West

Heber City, UT 84032

Miro Polycarbonate Resin

Dear Miro,

The purpose of this letter is to certify that the polycarbonate resin supplied by Biomerics to Miro Industries for use in its roofing systems is prime medical grade regrind polycarbonate resin. The material is from a single source pre-consumer feed stream and meets the performance requirements of Miro's material specification. The material is inspected and is free from foreign material contamination. Also, all products manufactured for Miro Industries by Biomerics are solely produced at Biomerics' facility in Salt Lake City, Utah.

Sincerely,

A handwritten signature in black ink that reads "Travis Sessions".

Travis Sessions

CEO

Biomerics, LLC.

2700 South 900 West, Ste D

Salt Lake City UT 84119

P 801-355-2705 F 801-355-3045



## TECHNICAL PROPERTIES FOR POLYCARBONATE RESIN

PROPERTY	ASTM TEST METHOD	VALUE	PROPERTY	ASTM TEST METHOD	VALUE
<b>PHYSICAL</b>			Volume Resistivity, ohm-cm @ 73 °F, dry (23 °C)	D257	>10 <sup>16</sup>
Specific Gravity	D792	1.20	Arc Resistance, sec	D495	10-11
Specific Volume, in <sup>3</sup> /lb (cm <sup>3</sup> /g)	—	23.1 (0.83)	Stainless Steel Electrodes		120
Weight Volume, lbs <sup>3</sup> /in (g/cm <sup>3</sup> )	—	0.043 (1.20)	Tungsten Electrodes		120
Water Absorption %	D570		<b>MECHANICAL</b>		
24 hours @ 73°F (23°C)		0.15	Tensile Strength, psi (MPa)	D638	
Equilibrium, 73°F (23°C)		0.35	Yield		9,000 (62)
Equilibrium, 212°F (100°C)		0.58	Ultimate		10,000 (69)
Mold Shrinkage, in/in (mm/mm)	D955	0.005-0.007	Elongation, %	D638	
Light Transmittance, % at 0.125"	D1003	89	Rupture		130
Haze, % @ 0.125"	D1003	1	Flexural Strength, psi (MPa)	D790	14,000 (97)
Refractive Index	—	1.586	Flexural Modulus, 10 <sup>5</sup> psi (MPa)	D790	3.40 (2,300)
<b>THERMAL</b>			Compressive Strength, psi (MPa)	D695	12,500 (86)
Deflection Temperature F°(C°)	D648		Compressive Modulus, psi (MPa)	D695	
@ 66 psi (0.46 MPa)		270 ( )	10 <sup>5</sup> osu (MPa)		3.45 (2,400)
@ 254 psi (1.82 MPa)		0.30 (1.25)	Shear Strength, psi (MPa)	D732	
Specific Heat, Btu/lb°F (kJ/kg°K)	—		Yield		6,000 (40)
Thermal Conductivity			Ultimate		10,000 (70)
Btu-in/h-ft <sup>2</sup> - °F (W/Km)	—	1.35 (.19)	Shear Modulus, 10 <sup>5</sup> psi (MPa)	—	1.14 (790)
Coefficient of Thermal Expansion			Izod Impact Strength, ft-lbs/in (J/m)	D1822	
in/in/°F (m.m /°C)	D696	3.75 x 10 <sup>-5</sup> (6.75 x 10 <sup>-5</sup> )	Notched, 1/8" thick (3.22mm)		15 (801)
Vicat Softening Temperature °F(°C)	D1525	305-315 (152-157)	Tensile Impact Strength, ft-lbs/in <sup>2</sup> (kJ/m <sup>2</sup> )	D1822	
Viscosity Midpoint	D1238	9.5	S-type		275 (579)
(Melt Flow Rate) g/10 min.	Condition 0		Dynatup Impact Strength, ft-lbs/in (J)	D3763	47 (64)
Brittleness Temperature °F (°C)	D746	<-200 (-129)	Fatigue Strength, psi @ 2.5mm cycles (MPa)	D671	1,000 (7.0)
Flammability Ratings			Rockwell Hardness	D785	
ASTM	D365°	AEB>1"	M		70
UL Standard 94 1/16" (1.6 mm)	UL94	V-2	R		118
UL Standard 94 1/8" (3.2 mm)	UL94	V-2	Deformation Under Load %	D621	
Oxygen Index	D2863	25.0	4000 psi @ 73°F (27 MPa @ 23°C)		0.2
			4000 psi @ 158°F (27 MPa @ 70°C)		0.5
<b>PHYSICAL</b>			Taber Abrasion Resistance		
Dielectric Strength, volts/mil (kV/mm)	D149	380 (15.0)	Weight Loss, mg/1000 cycles	D1044	10
Short time, 125 mils (3.2mm)					
Dielectric Constant	D150				
60 Hz		3.17			
10 <sup>6</sup> Hz		2.96			
Dielectric Factor	D150				
60 Hz		0.0009			
10 <sup>6</sup> Hz		0.010			

## **GENERAL INSTALLATION AND MAINTENANCE**

### **INSTALLATION:**

MIRO supports shall be installed per the product specifications or project specific submittals. Care must be taken when placing components on each support. Avoid dropping components or causing any undue impact on the support. Center the component being supported beneath the stand and adjust the stand accordingly to ensure even-load distribution to each frame. MIRO recommends an additional sheet of roofing material, or a support pad be installed beneath the base of each stand. For ballasted or built-up roofs, all loose aggregate shall be removed from an area 2 inches outside each base footprint.

### **MAINTENANCE:**

Normal maintenance is not required. Semi-annual inspection is required to check pipe stand position, to maintain pipe alignment, to check proper weight distribution and to correct improper installation that may cause pipe stand damage or failure.

The following inspection procedures should take place:

1. Determine that the component is still resting in a position centered over the stand, centered between the two bases, or centered properly in the hanger component.
2. Determine that the component is running at a perpendicular angle to the supporting product.
3. Determine that the base is still resting upon the additional sheet of roofing material, or the support pad.
4. Determine that each support is resting flat upon the roof and not angled in any manner. For example, a lateral force on a pipe stand as the pipe settles into its final resting position may cause enough force to push the pipe stand base upon a side or corner, which is an improper functioning position and could damage the roof.
5. Determine that the support structure and components are functioning properly. Look for any signs that the support or any of the components are not functioning properly.



## **PILLOW BLOCK SUPPORTS**

Our Pillow Block supports are an easy-to-install and low-cost solution to many of your basic rooftop support needs. The various models can support gas lines, electrical conduit, solar lines, or any other mechanical piping. The load-dispersing foot design can be used in conjunction with a spacer to add additional height, if required, or can be used on its own without risk of compromising the roof membrane. All Pillow Block Supports are made of 100% UV stable polycarbonate.

**Optimal Pipe Size:**  
Up to a 1-1/2" Pipe or  
1.9" Max OD

## Product Data Sheet

# 1.5 PILLOW BLOCK

1. **Product Name:** 1.5 Pillow Block. **NOTE:** The 1.5 Pillow Block support is designed to carry up to a 1-1/2 inch pipe with a maximum outside diameter of 1.9 inches.
2. **Manufacturer:** MIRO INDUSTRIES, INC.  
844 South 430 West, Suite 100,  
Heber City, Utah 84032  
Phone: (800) 768-6978  
Fax: (800) 440-7958
3. **Product Description:** A pipe support used to support roof-mounted gas pipes, electrical conduit, solar piping, or other mechanical piping. The unique design absorbs thermal expansion and contraction of pipes, thus preventing damage to the roof membrane. Pipes rest in a "U-shaped" cradle situated in a polycarbonate resin seat. Each pipe stand will accommodate up to 1-1/2 inch customary or "trade" size pipes. The maximum outside diameter of pipe, which can be cradled in the 1.5 Pillow Block support is 1.9 inches.
4. **Product Performance:** The design of the cradle serves to keep the pipestand system directly beneath the pipe without binding. All base edges are gently rounded to prevent gouging the roof membrane.
5. **Compatibility:** Pillow Block Pipestands are recommended and are compatible to use with all current deck types and with all commonly used built-up and single-ply roofing membranes where roof-mounted pipes occur.
6. **Load Weight:** Maximum load weight may not exceed 72 pounds per pipestand.
7. **Composition and Materials:** A one-piece base with a "U-shaped" housing. The pipestand is composed of rigid polycarbonate resin with carbon black added for UV-resistance and protection.
8. **Size:** The Pillow Block Pipestand Model 1.5 is made in one standard size. The deck base is 6 inches square, the top of the "U" cradle is 3 inches high, and the maximum inside width of the cradle is 1.9 inches. The pipestand has a clearance height of 2 inches from the roof to the bottom of the pipe or conduit. The 1.5 Spacers can be stacked 2 or 3 high, to give greater clearance from the roof to the bottom of the pipe or conduit. Each 1.5 Spacer increases the clearance height by 1.5 inches.
9. **Installation:** To install the pillow block pipestand, (1) center the pipestand beneath the pipe so that the pipe will rest centered in the cradle of the pipestand. (2) Set the pipe in the pipestand without dropping or causing any undue impact. (3) An additional sheet of roofing material, or a MIRO Support Pad should be installed beneath the pipestand. For built up roofs, clear all loose aggregate from an area 2 inches outside each base footprint and then follow the installation directions described above. Care should be taken to install each pipestand, so it supports a proportional and equal amount of weight with all other pipestands.  
  
In addition, the pipe may be secured to the pipestand by using a MIRO Pipe Guide and two #8 stainless-steel screws in the guide holes at the top of each pipestand. Note: the pipe guide should not be rigidly-attached to the pipe in the pipestand, thus allowing the supported pipe to expand and contract without binding.
10. **Spacing:** Manufacturer's recommended spacing is not to exceed 7 foot centers depending upon the load. Make certain each pipestand is properly elevated and adjusted to ensure even-load distribution to all pipestands. Support spacing is not to exceed the maximum spacing required in the pipe specifications, where applicable.
11. **Availability:** Pillow Block Pipestands are marketed throughout the United States through representatives and distributors.
12. **Maintenance:** Normal maintenance is not required. Semi-annual inspection is required to check pipestand position and set pipe alignment, check proper weight distribution, and to correct improper installation that may cause pipestand damage or failures.
13. **Technical Services:** Please call MIRO INDUSTRIES, INC: (800) 768-6978 or visit our website [www.miroind.com](http://www.miroind.com) for technical information and for graphic and CAD drawing downloads.

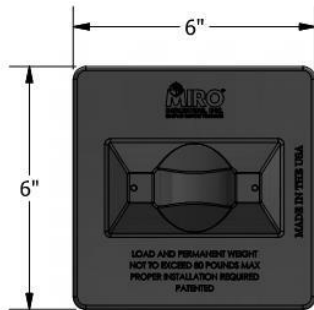

**TOP VIEW**

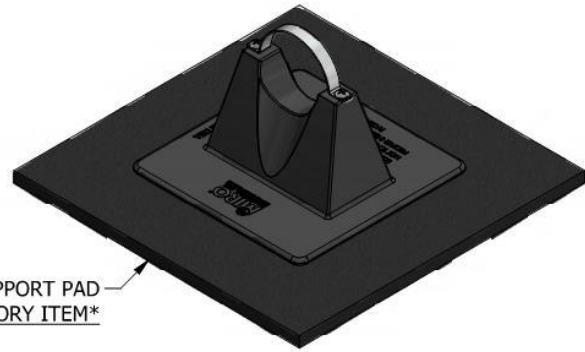

12 x 12 SUPPORT PAD  
\*ACCESSORY ITEM\*

**ISOMETRIC VIEW**

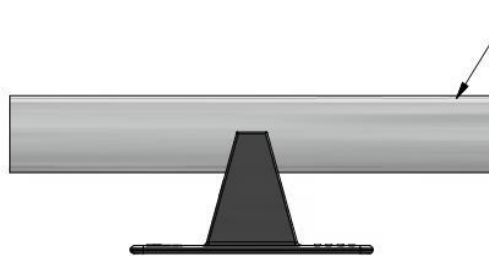

**SIDE VIEW**

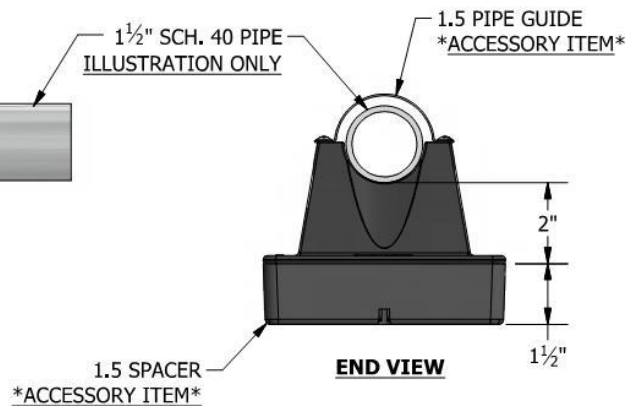

**END VIEW**

**ACCESSORIES**

- 1.5 pipe guide
- 1.5 spacer
- 12x12 Support pad
- Eternabond® 2-sided tape

**PRODUCT DESCRIPTION**

A pipe support used to support roof-mounted gas pipes, electrical conduit, solar piping and other mechanical piping. Unique design absorbs thermal expansion and contraction of pipes thus preventing damage to the roof membrane. Pipes rest in a 'U' shaped cradle situated in a polycarbonate resin base.

**KEY INFORMATION**

- Support is optimized to carry up to a 1½" pipe.
- Maximum pipe OD for the support is 1.9".
- Pipe clearance is 2"
- Maximum load is 72 lbs. based on 3.0 psi to the roof deck. Even load required.
- 63 per case, 22 lbs. per case, (DW= 14 lbs.)
- Recommended spacing is not to exceed 7' centers depending upon the load. Make certain each pipe support is properly elevated to evenly distribute weight at all pipe support locations.
- Base Material: Polycarbonate
- 20 Year Warranty

The information contained in this drawing is the sole property of MIRO Industries, Inc. Any reproduction in part or as a whole without written permission of MIRO Industries, Inc. is prohibited.

DATE:  
JAN 2019

1.5 PILLOW BLOCK



**Optimal Pipe Size:**  
Up to a 3" Pipe or  
3.6" Max OD

## Product Data Sheet

# 3.0 PILLOW BLOCK

1. **Product Name:** 3.0 Pillow Block. **NOTE:** The 3.0 Pillow Block support is designed to carry up to a 3 inch pipe with a maximum outside diameter of 3.6 inches.
2. **Manufacturer:** MIRO INDUSTRIES, INC. Phone: (800) 768-6978  
844 South 430 West, Suite 100, Fax: (800) 440-7958  
Heber City, Utah 84032
3. **Product Description:** A pipe support used to support roof-mounted gas pipes, electrical conduit, solar piping, or other mechanical piping. The unique design absorbs thermal expansion and contraction of pipes, thus preventing damage to the roof membrane. Pipes rest in a "U-shaped" cradle situated in a polycarbonate resin seat. Each pipe stand will accommodate up to a 3 inch customary or "trade" size pipes. The maximum outside diameter of pipe, which can be cradled in the 3.0 Pillow Block support is 3.6 inches.
4. **Product Performance:** The design of the cradle serves to keep the pipestand system directly beneath the pipe without binding. All base edges are gently rounded to prevent gouging the roof membrane.
5. **Compatibility:** Pillow Block Pipestands are recommended and are compatible to use with all current deck types and with all commonly used built-up and single-ply roofing membranes where roof-mounted pipes occur.
6. **Load Weight:** Maximum load weight may not exceed 120 pounds per pipestand.
7. **Composition and Materials:** A one-piece base with a "U-shaped" housing. The pipestand is composed of rigid polycarbonate resin with carbon black added for UV-resistance and protection.
8. **Size:** The Pillow Block Pipestand Model 3.0 is made in one standard size. The deck base is 7-3/4 inches square, the top of the "U" cradle is 6-7/16 inches high, and the maximum inside width of the cradle is 3.6 inches. The pipestand has a clearance height of 5 inches from the roof to the bottom of the pipe or conduit. The 3-R Spacers can be stacked 1 to 3 high, to give greater clearance from the roof to the bottom of the pipe or conduit. Each 3-R Spacer increases the clearance height by 2 inches.
9. **Installation:** To install the pillow block pipestand, (1) center the pipestand beneath the pipe so that the pipe will rest centered in the cradle of the pipestand. (2) Set the pipe in the pipestand without dropping or causing any undue impact. (3) An additional sheet of roofing material, or a MIRO Support Pad should be installed beneath the pipestand. For built up roofs, clear all loose aggregate from an area 2 inches outside each base footprint and then follow the installation directions described above. Care should be taken to install each pipestand, so it supports a proportional and equal amount of weight with all other pipestands.  
  
In addition, the pipe may be secured to the pipestand by using a MIRO Pipe Guide and two #8 stainless-steel screws in the guide holes at the top of each pipestand. Note: the pipe guide should not be rigidly-attached to the pipe in the pipestand, thus allowing the supported pipe to expand and contract without binding.
10. **Spacing:** Manufacturer's recommended spacing is not to exceed 10 foot centers depending upon the load. Make certain each pipestand is properly elevated and adjusted to ensure even-load distribution to all pipestands. Support spacing is not to exceed the maximum spacing required in the pipe specifications, where applicable.
11. **Availability:** Pillow Block Pipestands are marketed throughout the United States through representatives and distributors.
12. **Maintenance:** Normal maintenance is not required. Semi-annual inspection is required to check pipestand position and set pipe alignment, check proper weight distribution, and to correct improper installation that may cause pipestand damage or failures.
13. **Technical Services:** Please call MIRO INDUSTRIES, INC: (800) 768-6978 or visit our website [www.miroind.com](http://www.miroind.com) for technical information and for graphic and CAD drawing downloads.

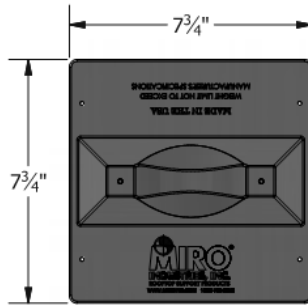

**TOP VIEW**

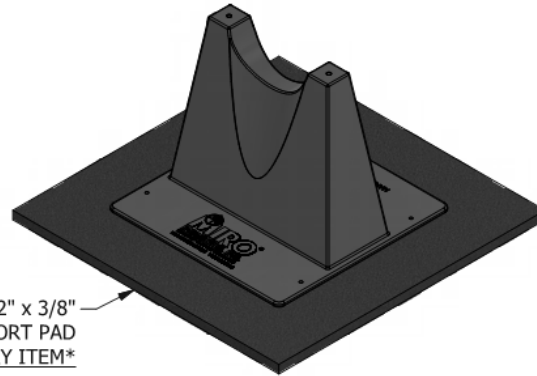

12" x 12" x 3/8"  
SUPPORT PAD  
\*ACCESSORY ITEM\*

**ISOMETRIC VIEW**

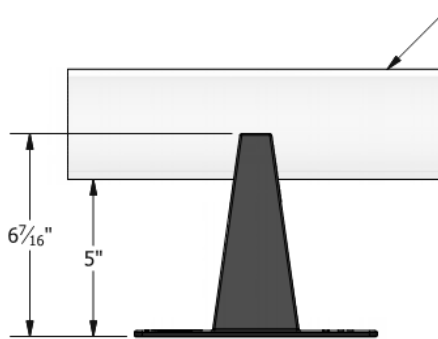

**SIDE VIEW**

3" SCH. 40 PIPE  
ILLUSTRATION ONLY

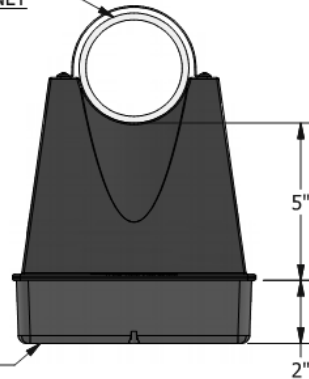

3-R SPACER  
\*ACCESSORY ITEM\*

**END VIEW**

**ACCESSORIES**

- 3.0 pipe guide
- 3-R spacer
- 12x12 Support pad
- Eternabond® 2-sided tape

**PRODUCT DESCRIPTION**

A pipe support used to support roof-mounted gas pipes, electrical conduit, solar piping and other mechanical piping. Unique design absorbs thermal expansion and contraction of pipes thus preventing damage to the roof membrane. Pipes rest in a 'U' shaped cradle situated in a polycarbonate resin base.

**KEY INFORMATION**

- Support is optimized to carry up to a 3" pipe.
- Maximum pipe OD for the support is 3.6".
- Pipe clearance is 5"
- 3-R Spacer accessory adds an additional 2" of height per spacer. Manufacturer recommends a maximum of (2) spacer be used.
- Maximum load is 120 lbs. based on 3.0 psi to the roof deck. Even load required.
- 16 per case, 20 lbs. per case, (DW= 16 lbs.)
- Recommended spacing is not to exceed 10' centers depending upon the load. Make certain each pipe support is properly elevated to evenly distribute weight at all pipe support locations.
- Base Material: Polycarbonate
- 20 Year Warranty

The information contained in this drawing is the sole property of MIRO Industries, Inc. Any reproduction in part or as a whole without written permission of MIRO Industries, Inc. is prohibited.	DATE:	<b>3.0 PILLOW BLOCK</b>
	JAN 2020	

**Optimal Pipe Size:**  
Up to a 3" Pipe or  
3-3/4" Max OD

## Product Data Sheet

### 3-R-2 and 3-R-4

1. **Product Name:** 3-R-2 and 3-R-4 Pillow Block Support. **NOTE:** The 3-R-2 and 3-R-4 Pillow Block supports are designed to carry up to a 3 inch pipe with a maximum outside diameter of 3-3/4 inches.
2. **Manufacturer:** MIRO INDUSTRIES, INC. Phone: (800) 768-6978  
844 South 430 West, Suite 100, Fax: (800) 440-7958  
Heber City, Utah 84032
3. **Product Description:** A "roller-bearing" pipe support used to support roof-mounted gas pipes, electrical conduit, solar piping, or other mechanical piping. The unique design absorbs thermal expansion and contraction of pipes, thus preventing damage to the roof membrane. Pipes rest on a polycarbonate resin roller and a polycarbonate axle situated in a polycarbonate resin base. The maximum pipe outside diameter (including insulation) is 3-3/4 inches.
4. **Product Performance:** The polycarbonate roller serves to keep the pipestand system directly beneath the pipe without binding. It also allows for some lateral expansion of the pipe system. All base edges are gently rounded to prevent gouging the roof membrane.
5. **Compatibility:** Pillow Block Pipestands are recommended and are compatible to use with all current deck types and with all commonly used built-up and single-ply roofing membranes where roof-mounted pipes occur.
6. **Load Weight:** Maximum load weight may not exceed 118 pounds per pipestand.
7. **Composition and Materials:** A one-piece roof deck base, a 9/16 inch diameter axle and a 3 inch roller support composed of rigid polycarbonate resin with carbon black added for UV-resistance and protection.
8. **Size:** The Pillow Block Pipestand Model 3-R-2 and 3-R-4 have a deck base of 7-3/4 inches square, the top of the cradle is 4 inches high, and the maximum width of the interior of the cradle is 3.875 inches. Components supported on the 3-R-2 pipestand will have a clearance of 2-1/8 inches. Components supported on the 3-R-4 pipestand will have a clearance of 4 inches. Model 3-R spacers can be stacked 1 to 3 high to give greater height to the pipe or conduit. Each 3-R spacer increases the clearance of the pipe by 2 inches.
9. **Installation:** To install the pillow block pipestand, (1) center the pipestand beneath the pipe so that the pipe will rest centered directly on the roller. (2) Set the pipe in the pipestand without dropping or causing any undue impact. (3) An additional sheet of roofing material, or a MIRO Support Pad should be installed beneath the pipestand. For built up roofs, clear all loose aggregate from an area 2 inches outside each base footprint and then follow the installation directions described above. Care should be taken to install each pipestand, so it supports a proportional and equal amount of weight with all other pipestands.  
  
In addition, the pipe may be secured to the pipestand by using a MIRO Pipe Guide and two #8 stainless-steel screws in the guide holes at the top of each pipestand. **Note:** the pipe guide should not be rigidly-attached to the pipe in the pipestand, thus allowing the supported pipe to expand and contract without binding.
10. **Spacing:** Manufacturer's recommended spacing is not to exceed 7 foot centers depending upon the load. Make certain each pipestand is properly elevated and adjusted to ensure even-load distribution to all pipestands. Support spacing is not to exceed the maximum spacing required in the pipe specifications, where applicable.
11. **Availability:** Pillow Block Pipestands are marketed throughout the United States through representatives and distributors.
12. **Maintenance:** Normal maintenance is not required. Semi-annual inspection is required to check pipestand position and set pipe alignment, check proper weight distribution, and to correct improper installation that may cause pipestand damage or failures.
13. **Technical Services:** Please call MIRO INDUSTRIES, INC: (800) 768-6978 or visit our website [www.miroind.com](http://www.miroind.com) for technical information and for graphic and CAD drawing downloads.



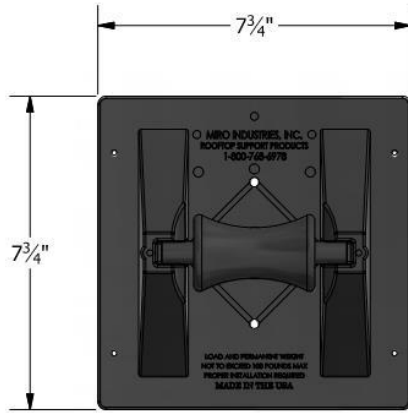

**TOP VIEW**

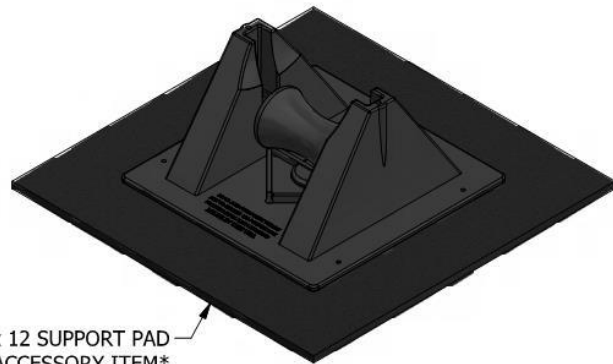

12 x 12 SUPPORT PAD  
\*ACCESSORY ITEM\*

**ISOMETRIC VIEW**

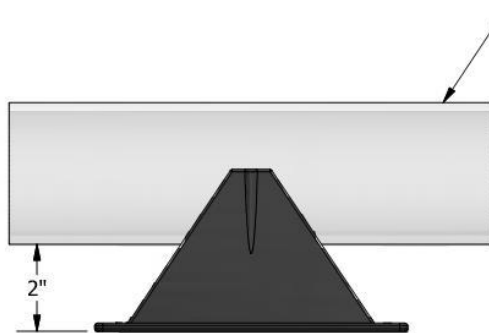

**SIDE VIEW**

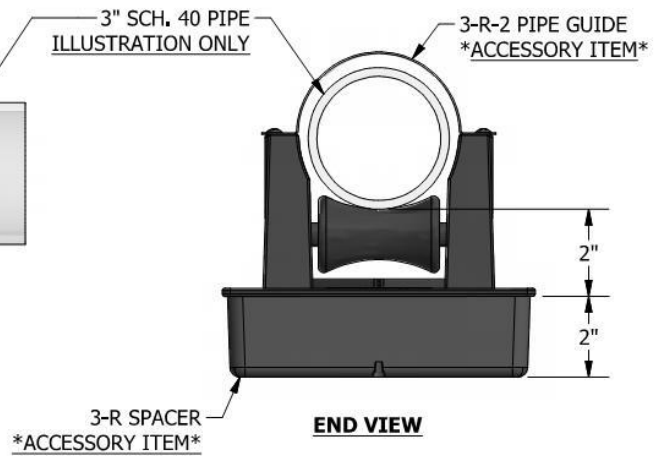

**END VIEW**

**ACCESSORIES**

- 3-R-2 pipe guide
- 3-R spacer
- Support pad
- Eternabond® 2-sided tape

**PRODUCT DESCRIPTION**

A "roller-bearing" pipe support used to support roof-mounted gas pipes, electrical conduit, solar piping and other mechanical piping. Unique design absorbs thermal expansion and contraction of pipes thus preventing damage to the roof membrane. Pipes rest on a polycarbonate resin roller and a rod situated in a polycarbonate resin seat.

**KEY INFORMATION**

- Support is optimized to carry up to a 3" pipe.
- Maximum pipe OD for the support is 3 3/4".
- Pipe clearance is 2"
- Maximum load is 118 lbs. based on 3.0 psi to the roof deck. Even load required.
- 24 per case, 26 lbs. per case, (DW= 21 lbs.)
- Recommended spacing is not to exceed 7' centers depending upon the load. Make certain each pipe support is properly elevated to evenly distribute weight at all pipe support locations.
- Base Material: Polycarbonate
- Axle and Roller Material: Polycarbonate
- 20 Year Warranty

The information contained in this drawing is the sole property of MIRO Industries, Inc. Any reproduction in part or as a whole without written permission of MIRO Industries, Inc. is prohibited.	DATE:	3-R-2
	JAN 2019	

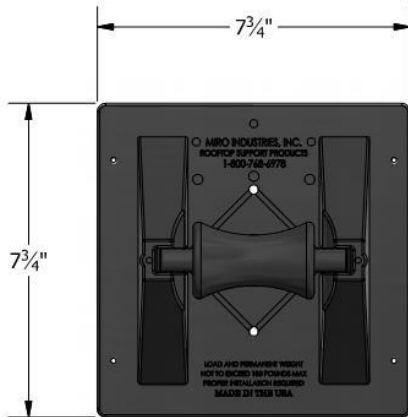

**TOP VIEW**

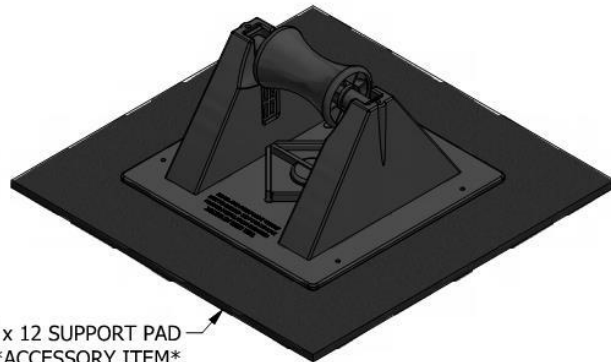

**ISOMETRIC VIEW**

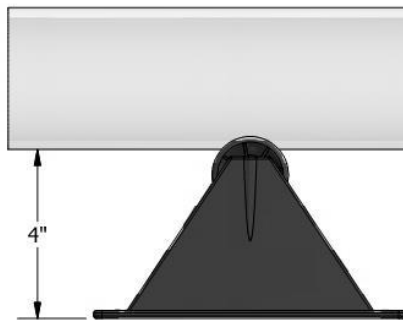

**SIDE VIEW**

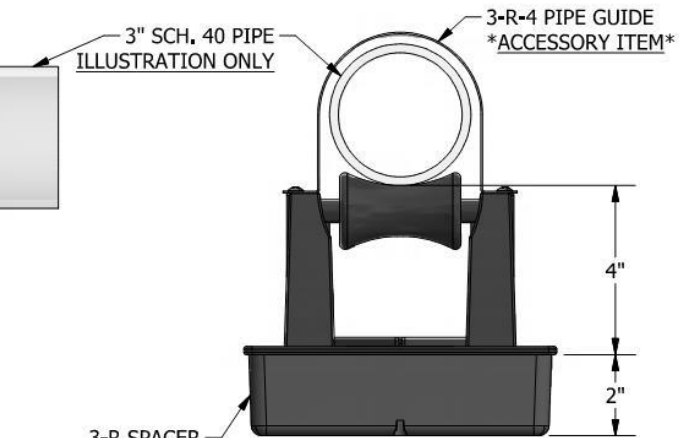

**END VIEW**

**ACCESSORIES**

- 3-R-4 pipe guide
- 3-R spacer
- Support pad
- Eternabond® 2-sided tape

**PRODUCT DESCRIPTION**

A "roller-bearing" pipe support used to support roof-mounted gas pipes, electrical conduit, solar piping and other mechanical piping.

Unique design absorbs thermal expansion and contraction of pipes thus preventing damage to the roof membrane.

Pipes rest on a polycarbonate resin roller and a rod situated in a polycarbonate resin seat.

**KEY INFORMATION**

- Support is optimized to carry up to a 3" pipe.
- Maximum pipe OD for the support is 3 3/4".
- Pipe clearance is 4"
- Maximum load is 118 lbs. based on 3.0 psi to the roof deck. Even load required.
- 24 per case, 27 lbs. per case, (DW=28 lbs.)
- Recommended spacing is not to exceed 7' centers depending upon the load. Make certain each pipe support is properly elevated to evenly distribute weight at all pipe support locations.
- Base Material: Polycarbonate
- Axle and Roller Material: Polycarbonate

The information contained in this drawing is the sole property of MIRO Industries, Inc. Any reproduction in part or as a whole without written permission of MIRO Industries, Inc. is prohibited.	DATE:	3-R-4
	JAN 2019	



## **ROLLER SERIES SUPPORTS**

Designed specifically for use in expansion/contraction applications, the Roller Series Supports use a roller to allow for longitudinal movement, while securely maintaining lateral alignment. The various models can support gas lines, electrical conduit, solar lines, or any other mechanical piping. These maintenance-free designs use self-lubricating rollers, UV and temperature-stable polycarbonate, stainless-steel all-thread, and hot-dip galvanized hardware. Some Roller Series Supports are also available with a stainless-steel base. The appropriate MIRO Support Pad is recommended for additional protection of the roof membrane. Roller Series Supports are optimally designed to carry up to a 10 inch pipe and can elevate pipes from 3-7/8 inches to 18 inches above the roof surface.

**Optimal Pipe Size:**  
Up to a 3" Pipe or  
5-1/2" Max OD

## Product Data Sheet

# 3-RAH-8 and 3-RAH-12

- Product Name:** Roller Support 3-RAH-8 and 3-RAH-12. **NOTE:** Roller Support pipestand model numbers correspond to the optimal pipe sizes for the support. With variation in pipe wall thickness and actual outside dimensions, or where the pipe is insulated, the 3-RAH-8 and 3-RAH-12 can accommodate up to a 5-1/2 inches maximum outside diameter. The 3-RAH-8 and 3-RAH-12 will hold up to all nominal and customary 3 inch and smaller pipe sizes. Larger pipe with up to a maximum outside diameter of 5-1/2 inches may be placed on the Model 3-RAH-8 and 3-RAH-12 at reduced support spacing as approved by MIRO Industries.
- Manufacturer:** MIRO INDUSTRIES, INC. Phone: (800) 768-6978  
844 South 430 West, Suite 100, Fax: (800) 440-7958  
Heber City, Utah 84032
- Product Description:** A "roller-bearing" pipe support used to support roof-mounted gas pipes, electrical conduit, solar piping, or other mechanical piping. The unique design absorbs thermal expansion and contraction of pipes thus preventing damage to the roof membrane. Pipes rest on a polycarbonate resin roller and a polycarbonate axle collar assembly that is attached to a polycarbonate resin base via 3/8 inch stainless-steel all-thread. The height of the roller assembly can be adjusted down on the all-thread to meet project specific heights and slopes.
- Product Performance:** The polycarbonate roller serves to keep the pipestand system directly beneath the pipe without binding. It also allows for some lateral expansion of the pipe system. All base edges are gently rounded to prevent gouging the roof membrane.
- Compatibility:** The 3-RAH-8 and 3-RAH-12 pipestands are recommended and are compatible to use with all current deck types and with all commonly used built-up and single-ply roofing membranes where roof-mounted pipes occur.
- Load Weight:** Maximum load weight may not exceed 172 pounds per pipestand.
- Composition and Materials:** The pipestand consists of three major components: (1) A polycarbonate resin deck base, (2) stainless-steel vertical all-thread with hot-dip galvanized hardware, and (3) a polycarbonate axle/roller assembly. Carbon black is added to the polycarbonate resin for UV-resistance and protection.
- Size:** The 3-RAH-8 and 3-RAH-12 have a 7-1/2 x 10 inch deck base and a roller assembly that can carry up to a 5-1/2 inch maximum outside diameter pipe (including insulation). The 3-RAH support series is optimally designed to carry a 3 inch pipe. The 3-RAH-8 can adjust in height from the factory-set maximum height of 8 inches down to 3-7/8 inches from the deck to the bottom of the pipe. The 3-RAH-12 can adjust in height from the factory-set maximum height of 12 inches down to 3-7/8 inches from the deck to the bottom of the pipe.
- Installation:** To install the 3-RAH series pipestand, (1) center the pipestand beneath the pipe so that the pipe will rest centered directly on the roller. (2) Set the pipe in the pipestand without dropping or causing any undue impact. (3) An additional sheet of roofing material, or a MIRO Support Pad should be installed beneath the pipestand. For built up roofs, clear all loose aggregate from an area 2 inches outside each base footprint and then follow the installation directions outlined above. Care should be taken to install each pipestand, so it supports a proportional and equal amount of weight with all other pipestands.  
  
In addition, the pipe may be secured to the pipestand by using a MIRO Pipe Guide. The pipe guide is attached to the stand by removing the nuts from the top of the support, placing the pipe guide on the all-thread and re-installing the nuts. **Note:** the pipe guide should not be rigidly-attached to the pipe in the pipestand, thus allowing the supported pipe to expand and contract without binding.
- Spacing:** Manufacturer's recommended spacing is not to exceed 10 foot centers depending upon the load. Make certain each pipestand is properly elevated and adjusted to ensure even-load distribution to all pipestands. Support spacing is not to exceed the maximum spacing required in the pipe specifications, where applicable.
- Availability:** The 3-RAH-8 and 3-RAH-12 pipestands are marketed throughout the United States through representatives and distributors.
- Maintenance:** Normal maintenance is not required. Semi-annual inspection is required to check pipestand position and set pipe alignment, check proper weight distribution, and to correct improper installation that may cause pipestand damage or failures.
- Technical Services:** Please call MIRO INDUSTRIES, INC: (800) 768-6978 or visit our website [www.miroind.com](http://www.miroind.com) for technical information and for graphic and CAD drawing downloads.



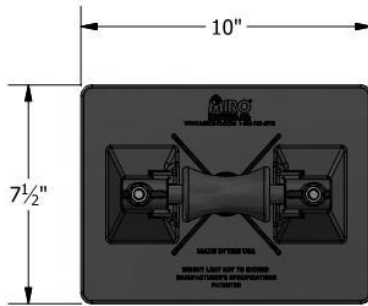

**TOP VIEW**

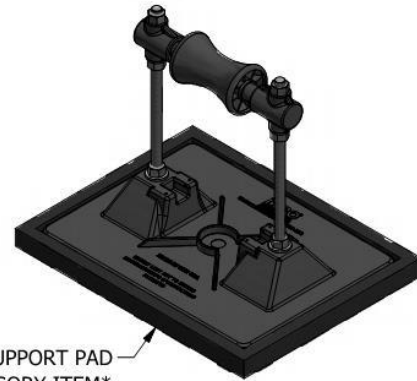

7 1/2" x 10" SUPPORT PAD  
\*ACCESSORY ITEM\*

**ISOMETRIC VIEW**

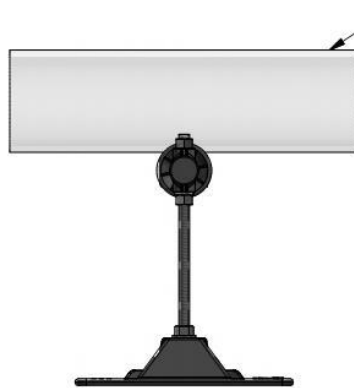

**SIDE VIEW**

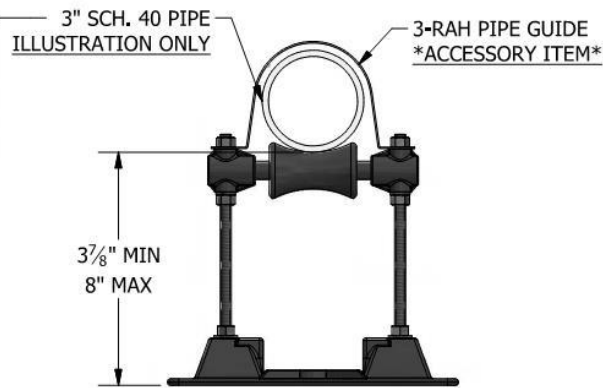

**END VIEW**

**ACCESSORIES**

- Refer to 3-RAH Pipe Guide specification for available sizes.
- 7 1/2" x 10" Support pad
- Eternabond® 2-sided tape

**PRODUCT DESCRIPTION**

A "roller-bearing" pipe support used to support roof-mounted gas pipes, electrical conduit, solar piping and other mechanical piping. Unique design absorbs thermal expansion and contraction of pipes thus preventing damage to the roof membrane. Pipes rest on a self-lubricating polycarbonate resin axle and roller.

**KEY INFORMATION**

- Optimally designed for a 3" pipe.
- Maximum pipe OD (with insulation) is 5-1/2".
- Adjustable from the factory set maximum height of 8" down to a minimum height of 3-7/8".
- Maximum load is 172 lbs. (3.0 psi) Make certain each pipe support is properly elevated to evenly distribute weight at all pipe support locations.
- Unit weight: 1.72 lbs.
- 12 per case, 21 lbs., (DW=29 lbs.)
- Recommended spacing is not to exceed 10' centers depending upon the load.
- Base Material: Polycarbonate
- Roller, Axle and Collar Material: Polycarbonate
- 3/8" all-thread is stainless steel
- All other metal parts are hot-dip galvanized

The information contained in this drawing is the sole property of MIRO Industries, Inc. Any reproduction in part or as a whole without written permission of MIRO Industries, Inc. is prohibited.	DATE:	3-RAH-8
	JAN 2019	

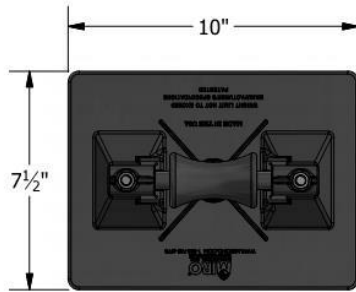

**TOP VIEW**

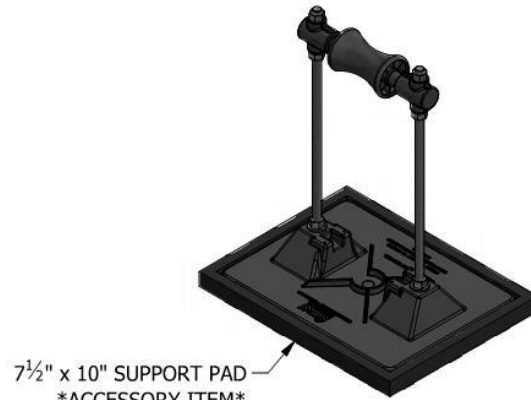

**ISOMETRIC VIEW**



**SIDE VIEW**

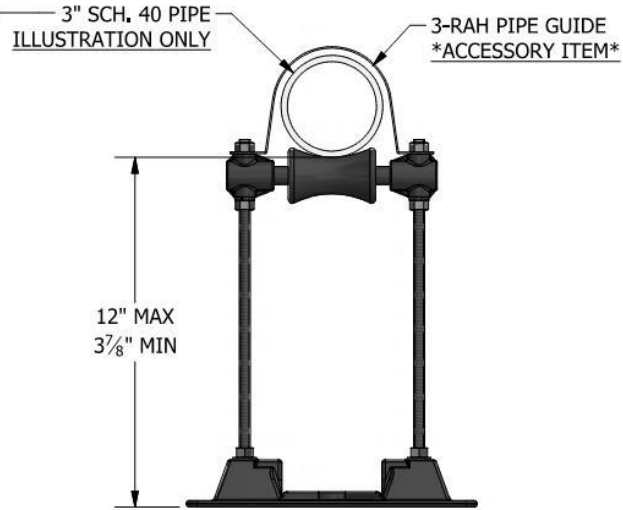

**END VIEW**

**ACCESSORIES**

- Refer to 3-RAH Pipe Guide specification for available sizes.
- 7½" x 10" Support pad
- Eternabond® 2-sided tape

**PRODUCT DESCRIPTION**

A "roller-bearing" pipe support used to support roof-mounted gas pipes, electrical conduit, solar piping and other mechanical piping. Unique design absorbs thermal expansion and contraction of pipes thus preventing damage to the roof membrane. Pipes rest on a self-lubricating polycarbonate resin axle and roller.

**KEY INFORMATION**

- Optimally designed for a 3" pipe.
- Maximum pipe OD (with insulation) is 5-1/2".
- Adjustable from the factory set maximum height of 12" down to a minimum height of 3-7/8".
- Maximum load is 172 lbs. (3.0 psi) Make certain each pipe support is properly elevated to evenly distribute weight at all pipe support locations.
- Unit weight: 1.96 lbs.
- 7 per case, 16 lbs., (DW=20 lbs.)
- Recommended spacing is not to exceed 10' centers depending upon the load.
- Base Material: Polycarbonate
- Roller, Axle and Collar Material: Polycarbonate
- 3/8" all-thread is stainless steel
- All other metal parts are hot-dip galvanized

The information contained in this drawing is the sole property of MIRO Industries, Inc. Any reproduction in part or as a whole without written permission of MIRO Industries, Inc. is prohibited.

DATE:  
JAN 2019

3-RAH-12

**Optimal Pipe Size:**

Up to a 4" Pipe or  
5-1/2" Max OD

**Product Data Sheet**

**4-RAH-10 and 4-RAH-14**

1. **Product Name:** Roller Support 4-RAH-10 and 4-RAH-14. **NOTE:** Roller Support pipestand model numbers correspond to the optimal pipe sizes for the support. With variation in pipe wall thickness and actual outside dimensions, or where the pipe is insulated, the 4-RAH-10 and 4-RAH-14 can accommodate up to a 5-1/2 inch maximum outside diameter. The 4-RAH-10 and 4-RAH-14 will hold up to all nominal and customary 4 inch and smaller pipe sizes. Larger pipe with up to a maximum outside diameter of 5-1/2 inches may be placed on the Model 4-RAH-10 and 4-RAH-14 at reduced support spacing as approved by MIRO Industries.
2. **Manufacturer:** MIRO INDUSTRIES, INC. Phone: (800) 768-6978  
844 South 430 West, Suite 100, Fax: (800) 440-7958  
Heber City, Utah 84032
3. **Product Description:** A "roller-bearing" pipe support used to support roof-mounted gas pipes, electrical conduit, solar piping, or other mechanical piping. The unique design absorbs thermal expansion and contraction of pipes thus preventing damage to the roof membrane. Pipes rest on a polycarbonate resin roller and a polycarbonate axle collar assembly that is attached to a polycarbonate resin base via 3/8 inch stainless-steel all-thread. The height of the roller assembly can be adjusted down on the all-thread to meet project specific heights and slopes.
4. **Product Performance:** The polycarbonate roller serves to keep the pipestand system directly beneath the pipe without binding. It also allows for some lateral expansion of the pipe system. All base edges are gently rounded to prevent gouging the roof membrane.
5. **Compatibility:** The 4-RAH-10 and 4-RAH-14 pipestands are recommended and are compatible to use with all current deck types and with all commonly used built-up and single-ply roofing membranes where roof-mounted pipes occur.
6. **Load Weight:** Maximum load weight on the 4-RAH-10 may not exceed 335 pounds per pipestand. Maximum load weight on the 4-RAH-14 may not exceed 186 pounds per pipestand.
7. **Composition and Materials:** The pipestand consists of three major components: (1) A polycarbonate resin deck base, (2) stainless-steel vertical all-thread with hot-dip galvanized hardware, and (3) a polycarbonate axle/roller assembly. Carbon black is added to the polycarbonate resin for UV-resistance and protection.
8. **Size:** The 4-RAH-10 and 4-RAH-14 have a 9 x 15-1/4 inch deck base and a roller assembly that can carry up to a 5-1/2 inch maximum outside diameter pipe (including insulation). The 4-RAH-10 and 4-RAH-14 supports are optimally designed to carry a 4 inch pipe. The 4-RAH-10 can adjust from the factory-set maximum height of 9-5/8 inches down to 4-1/2 inches from the deck to the bottom of the pipe. The 4-RAH-14 can adjust from the factory-set maximum height of 13-5/8 inches down to 4-1/2 inches from the deck to the bottom of the pipe.
9. **Installation:** To install the 4-RAH series pipestand, (1) center the pipestand beneath the pipe so that the pipe will rest centered directly on the roller. (2) Set the pipe in the pipestand without dropping or causing any undue impact. (3) An additional sheet of roofing material, or a MIRO Support Pad should be installed beneath the pipestand. For built up roofs, clear all loose aggregate from an area 2 inches outside each base footprint and then follow the installation directions outlined above. Care should be taken to install each pipestand, so it supports a proportional and equal amount of weight with all other pipestands.  
  
In addition, the pipe may be secured to the pipestand by using a MIRO Pipe Guide. The pipe guide is attached to the stand by removing the nuts from the top of the support, placing the pipe guide on the all-thread and re-installing the nuts. **Note:** the pipe guide should not be rigidly-attached to the pipe in the pipestand, thus allowing the supported pipe to expand and contract without binding.
10. **Spacing:** Manufacturer's recommended spacing is not to exceed 10 foot centers depending upon the load. Make certain each pipestand is properly elevated and adjusted to ensure even-load distribution to all pipestands. Support spacing is not to exceed the maximum spacing required in the pipe specifications, where applicable.
11. **Availability:** The 4-RAH-10 and 4-RAH-14 pipestands are marketed throughout the United States through representatives and distributors.
12. **Maintenance:** Normal maintenance is not required. Semi-annual inspection is required to check pipestand position and set pipe alignment, check proper weight distribution, and to correct improper installation that may cause pipestand damage or failures.
13. **Technical Services:** Please call MIRO INDUSTRIES, INC: (800) 768-6978 or visit our website [www.miroind.com](http://www.miroind.com) for technical information and for graphic and CAD drawing downloads.

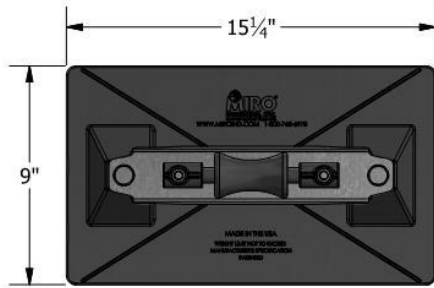

**TOP VIEW**



**ISOMETRIC VIEW**



**SIDE VIEW**

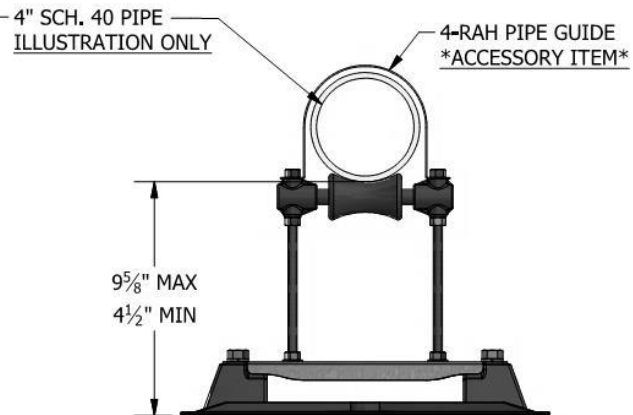

**END VIEW**

**ACCESSORIES**

- Refer to 4-RAH Pipe Guide specification for available sizes,
- Support pad or deck plate
- Eternabond® 2-sided tape

**PRODUCT DESCRIPTION**

A "roller-bearing" pipe support used to support roof-mounted gas pipes, electrical conduit, solar piping and other mechanical piping. Unique design absorbs thermal expansion and contraction of pipes thus preventing damage to the roof membrane. Pipes rest on a self-lubricating polycarbonate resin axle and roller.

**KEY INFORMATION**

- Optimally designed for a 4" pipe.
- Maximum pipe OD (with insulation) is 5-1/2".
- Adjustable from the factory set maximum height of 9-5/8" down to a minimum height of 4-1/2".
- Maximum load is 335 lbs. (3.0 psi) Make certain each pipe support is properly elevated to evenly distribute weight at all pipe support locations.
- Unit weight: 3.25 lbs.
- 7 per case, 25 lbs., (DW=36 lbs.)
- Recommended spacing is not to exceed 10' centers depending upon the load.
- Base Material: Polycarbonate
- Roller, Axle and Collar Material: Polycarbonate
- 3/8" all-thread is stainless steel
- All other metal parts are hot-dip galvanized

The information contained in this drawing is the sole property of MIRO Industries, Inc. Any reproduction in part or as a whole without written permission of MIRO Industries, Inc. is prohibited.	DATE:	4-RAH-10
	JAN 2019	



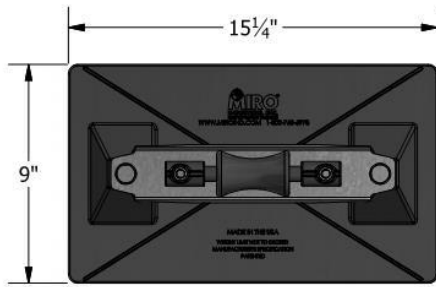

**TOP VIEW**



9" x 15-1/4" SUPPORT PAD  
\*ACCESSORY ITEM\*

**ISOMETRIC VIEW**



**SIDE VIEW**

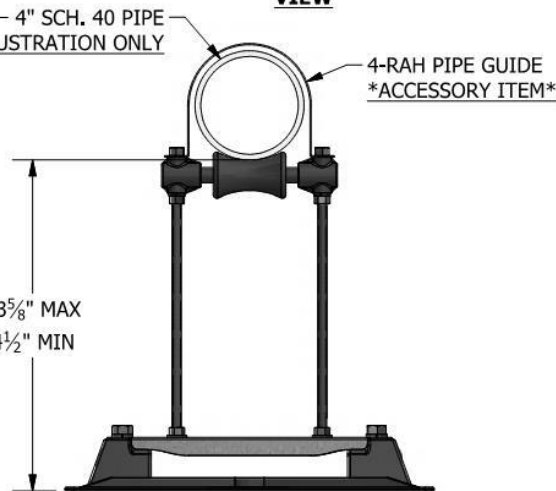

**END VIEW**

**ACCESSORIES**

- Refer to 4-RAH Pipe Guide specification for available sizes.
- 9" x 15 1/4" Support pad
- Eternabond® 2-sided tape

**PRODUCT DESCRIPTION**

A "roller-bearing" pipe support used to support roof-mounted gas pipes, electrical conduit, solar piping and other mechanical piping. Unique design absorbs thermal expansion and contraction of pipes thus preventing damage to the roof membrane. Pipes rest on a self-lubricating polycarbonate resin axle and roller.

**KEY INFORMATION**

- Optimally designed for a 4" pipe.
- Maximum pipe OD (with insulation) is 5-1/2".
- Adjustable from the factory set maximum height of 13-5/8" down to a minimum height of 4-1/2".
- Maximum load is 186 lbs. (All-thread capacity) Make certain each pipe support is properly elevated to evenly distribute weight at all pipe support locations.
- Unit weight: 3,48 lbs.
- 5 per case, 19 lbs., (DW=36 lbs.)
- Recommended spacing is not to exceed 10' centers depending upon the load.
- Base Material: Polycarbonate
- Roller, Axle and Collar Material: Polycarbonate
- 3/8" all-thread is stainless steel
- All other metal parts are hot-dip galvanized

The information contained in this drawing is the sole property of MIRO Industries, Inc. Any reproduction in part or as a whole without written permission of MIRO Industries, Inc. is prohibited.	DATE:	4-RAH-14
	JAN 2019	

**Optimal Pipe Size:**  
Up to a 4" Pipe or  
5-1/2" Max OD

## Product Data Sheet

# 4-RAH-8 SS and 4-RAH-12 SS

1. **Product Name:** Roller Support 4-RAH-8 SS and 4-RAH-12 SS. **NOTE:** Roller Support pipestand model numbers correspond to the optimal pipe sizes for the support. With variation in pipe wall thickness and actual outside dimensions, or where the pipe is insulated, the 4-RAH-8 SS and 4-RAH-12 SS can accommodate up to a 5-1/2 inch maximum outside diameter. The 4-RAH-8 SS and 4-RAH-12 SS will hold up to all nominal and customary 4 inch and smaller pipe sizes. Larger pipe with up to a maximum outside diameter of 5-1/2 inches may be placed on the Model 4-RAH-8 SS and 4-RAH-12 SS at reduced support spacing as approved by MIRO Industries.
2. **Manufacturer:** MIRO INDUSTRIES, INC. Phone: (800) 768-6978  
844 South 430 West, Suite 100, Fax: (800) 440-7958  
Heber City, Utah 84032
3. **Product Description:** A "roller-bearing" pipe support used to support roof-mounted gas pipes, electrical conduit, solar piping, or other mechanical piping. The unique design absorbs thermal expansion and contraction of pipes, thus preventing damage to the roof membrane. Pipes rest on a polycarbonate resin roller and a polycarbonate axle collar assembly that is attached to a stainless-steel base via 3/8 inch stainless-steel all-thread. The height of the roller assembly can be adjusted down on the all-thread to meet project specific heights and slopes.
4. **Product Performance:** The polycarbonate roller serves to keep the pipestand system directly beneath the pipe without binding. It also allows for some lateral expansion of the pipe system. All base edges are gently rounded to prevent gouging the roof membrane.
5. **Compatibility:** The 4-RAH-8 SS and 4-RAH-12 SS pipestands are recommended and are compatible to use with all current deck types and with all commonly used built-up and single-ply roofing membranes where roof-mounted pipes occur.
6. **Load Weight:** Maximum load weight on the 4-RAH-8 SS may not exceed 419 pounds per pipestand. Maximum load weight on the 4-RAH-12 SS may not exceed 186 pounds per pipestand.
7. **Composition and Materials:** The pipestand consists of three major components: (1) A stainless-steel deck base, (2) stainless-steel vertical all-thread with hot-dip galvanized hardware, and (3) a polycarbonate axle/roller assembly. Carbon black is added to the polycarbonate resin for UV-resistance and protection.
8. **Size:** The 4-RAH-8 SS and 4-RAH-12 SS have a 12x16 inch deck base and a roller assembly that can carry up to a 5-1/2 inch maximum outside diameter pipe (including insulation). The 4-RAH SS support series is optimally designed to carry a 4 inch pipe. The 4-RAH-8 SS can adjust in height from the factor set height of 8 inches down to 3-3/4 inches from the deck to the bottom of the pipe. The 4-RAH-12 can adjust in height from the factory-set height of 12 inches down to 3-3/4 inches from the deck to the bottom of the pipe.
9. **Installation:** To install the 4-RAH series pipestand, (1) center the pipestand beneath the pipe so that the pipe will rest centered directly on the roller. (2) Set the pipe in the pipestand without dropping or causing any undue impact. (3) An additional sheet of roofing material, or a MIRO Support Pad should be installed beneath the pipestand. For built up roofs, clear all loose aggregate from an area 2 inches outside each base footprint and then follow the installation directions outlined above. Care should be taken to install each pipestand, so it supports a proportional and equal amount of weight with all other pipestands.  
  
In addition, the pipe may be secured to the pipestand by using a MIRO Pipe Guide. The pipe guide is attached to the stand by removing the nuts from the top of the support, placing the pipe guide on the all-thread and re-installing the nuts. **Note:** the pipe guide should not be rigidly-attached to the pipe in the pipestand, thus allowing the supported pipe to expand and contract without binding.
10. **Spacing:** Manufacturer's recommended spacing is not to exceed 10 foot centers depending upon the load. Make certain each pipestand is properly elevated and adjusted to ensure even-load distribution to all pipestands. Support spacing is not to exceed the maximum spacing required in the pipe specifications, where applicable.
11. **Availability:** 4-RAH SS series pipestands are marketed throughout the United States through representatives and distributors.
12. **Maintenance:** Normal maintenance is not required. Semi-annual inspection is required to check pipestand position and set pipe alignment, check proper weight distribution, and to correct improper installation which may cause pipestand damage or failures.
13. **Technical Services:** Please call MIRO INDUSTRIES, INC: (800) 768-6978 or visit our website [www.miroind.com](http://www.miroind.com) for technical information and for graphic and CAD drawing downloads.

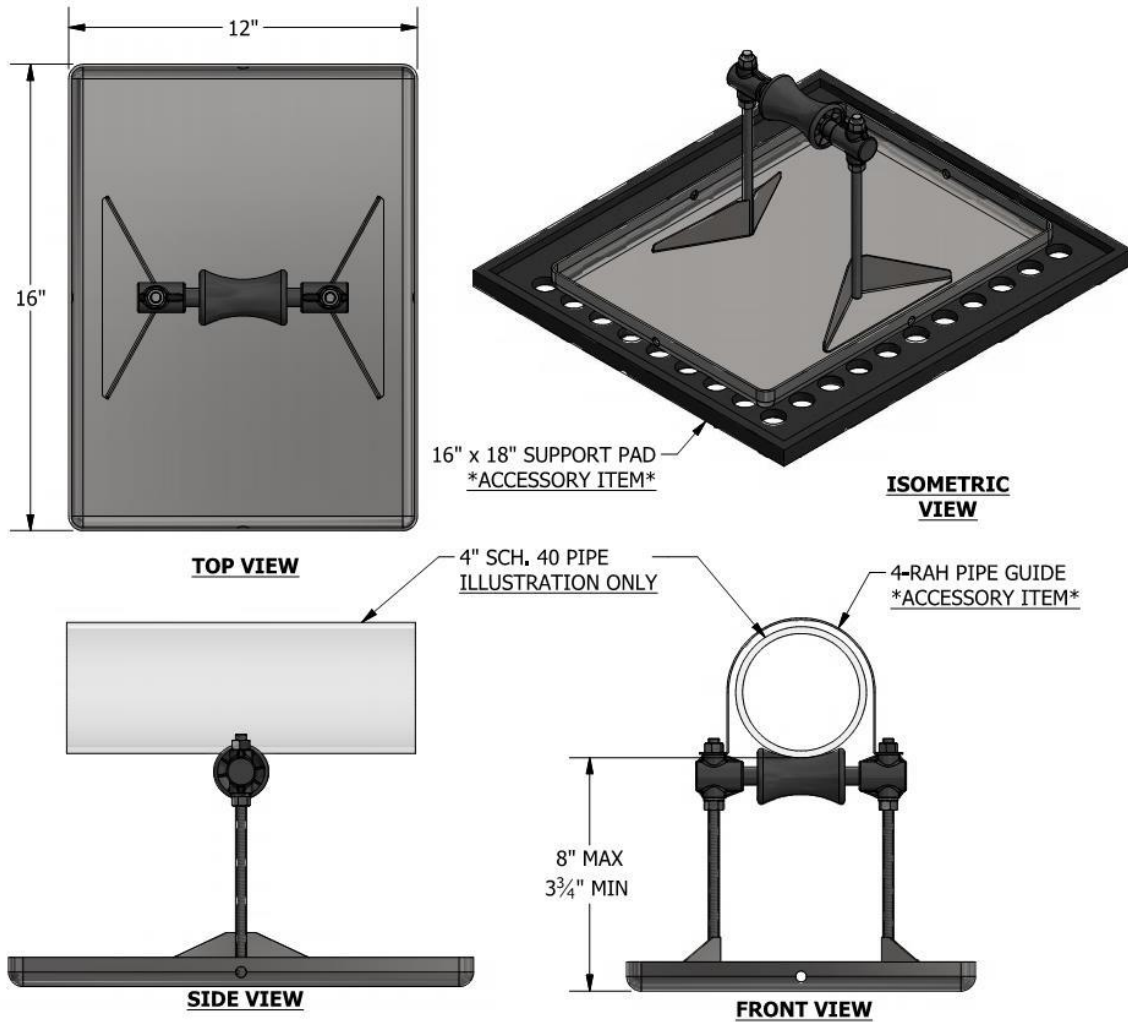

**ACCESSORIES**

- Refer to 4-RAH Pipe Guide specification for available sizes.
- 16" x 18" Support pad
- Eternabond® 2-sided tape

**PRODUCT DESCRIPTION**

A "roller-bearing" pipe support used to support roof-mounted gas pipes, electrical conduit, solar piping and other mechanical piping. Unique design absorbs thermal expansion and contraction of pipes thus preventing damage to the roof membrane. Pipes rest on a self-lubricating polycarbonate resin axle and roller.

**KEY INFORMATION**

- Optimally designed for a 4" pipe.
- Maximum pipe OD (with insulation) is 5-1/2".
- Adjustable from the factory set maximum height of 8" down to a minimum height of 3-3/4".
- Maximum load is 419 lbs. (3.0 psi) Make certain each pipe support is properly elevated to evenly distribute weight at all pipe support locations.
- Unit weight: 8.08 lbs.
- Recommended spacing is not to exceed 10' centers depending upon the load.
- Base Material: Stainless Steel
- Roller, Axle and Collar Material: Polycarbonate
- 3/8" all-thread is stainless steel
- All other metal parts are hot-dip galvanized

The information contained in this drawing is the sole property of MIRO Industries, Inc. Any reproduction in part or as a whole without written permission of MIRO Industries, Inc. is prohibited.	DATE:	4-RAH-8 SS
	JAN 2019	

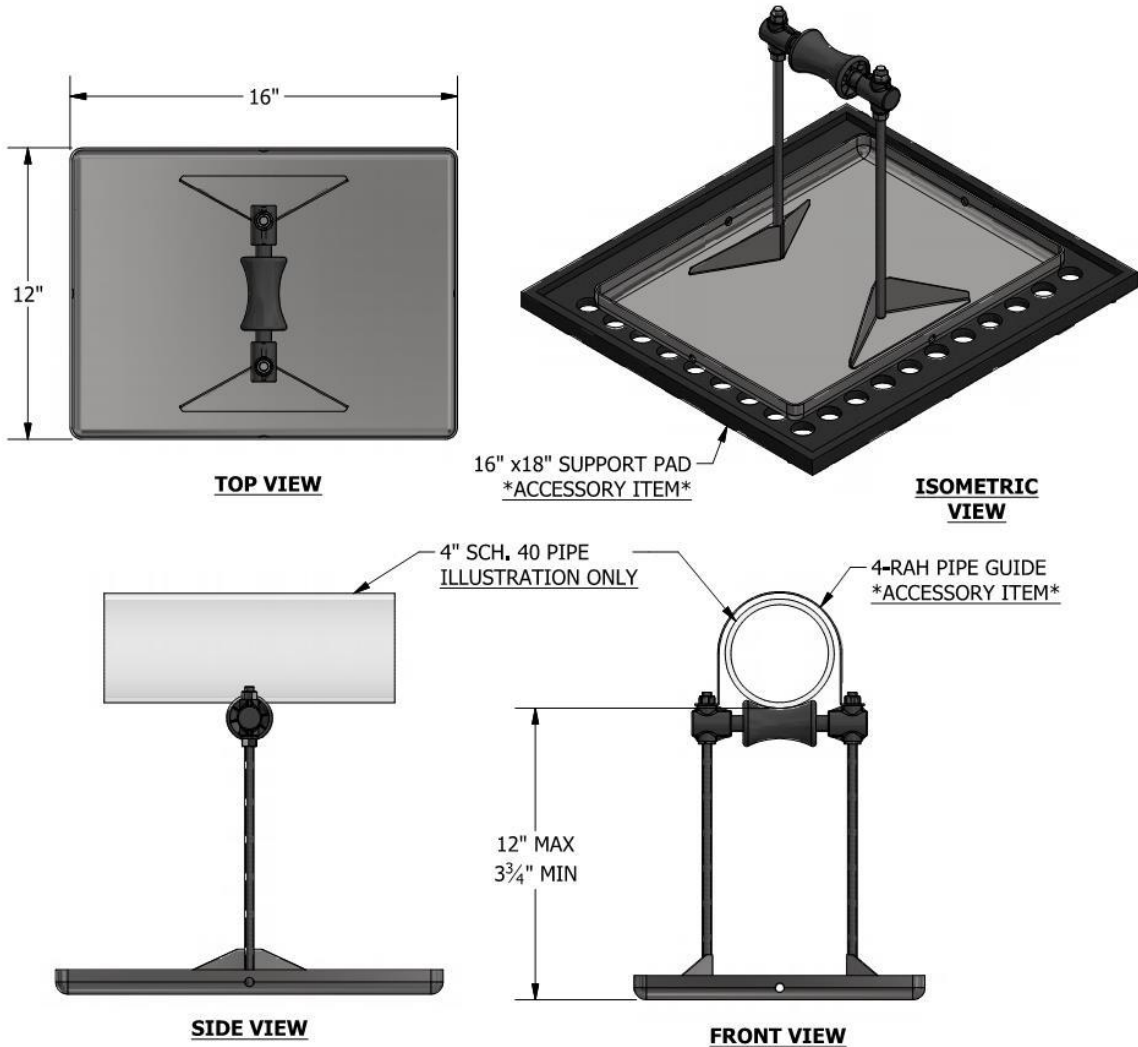

**ACCESSORIES**

- Refer to 4-RAH Pipe Guide specification for available sizes.
- 16" x 18" Support pad
- Eternabond® 2-sided tape

**PRODUCT DESCRIPTION**

A "roller-bearing" pipe support used to support roof-mounted gas pipes, electrical conduit, solar piping and other mechanical piping. Unique design absorbs thermal expansion and contraction of pipes thus preventing damage to the roof membrane. Pipes rest on a self-lubricating polycarbonate resin axle and roller.

**KEY INFORMATION**

- Optimally designed for a 4" pipe.
- Maximum pipe OD (with insulation) is 5-1/2".
- Adjustable from the factory set maximum height of 12" down to a minimum height of 3-3/4".
- Maximum load is 186 lbs. (All-thread capacity) Make certain each pipe support is properly elevated to evenly distribute weight at all pipe support locations.
- Unit weight: 8.32 lbs.
- Recommended spacing is not to exceed 10' centers depending upon the load.
- Base Material: Stainless Steel
- Roller, Axle and Collar Material: Polycarbonate
- 3/8" all-thread is stainless steel
- All other metal parts are hot-dip galvanized

The information contained in this drawing is the sole property of MIRO Industries, Inc. Any reproduction in part or as a whole without written permission of MIRO Industries, Inc. is prohibited.	DATE:	4-RAH-12 SS
	JAN 2019	



**Optimal Pipe Size:**  
Up to a 5" Pipe or  
8-1/2" Max OD

## Product Data Sheet

# 5-RAH-8 and 5-RAH-12

- Product Name:** Roller Support 5-RAH-8 and 5-RAH-12. **NOTE:** Roller Support pipestand model numbers correspond to the optimal pipe sizes for the support. With variation in pipe wall thickness and actual outside dimensions, or where the pipe is insulated, the 5-RAH-8 and 5-RAH-12 can accommodate up to an 8-1/2 inch maximum outside diameter. The 5-RAH-8 and 5-RAH-12 will hold up to all nominal and customary 5 inch and smaller pipe sizes. Larger pipe with up to a maximum outside diameter of 8-1/2 inches may be placed on the Model 5-RAH-8 and 5-RAH-12 at reduced support spacing as approved by MIRO Industries.
- Manufacturer:** MIRO INDUSTRIES, INC.  
844 South 430 West, Suite 100,  
Heber City, Utah 84032  
Phone: (800) 768-6978  
Fax: (800) 440-7958
- Product Description:** A "roller-bearing" pipe support used to support roof-mounted gas pipes, electrical conduit, solar piping, or other mechanical piping. The unique design absorbs thermal expansion and contraction of pipes, thus preventing damage to the roof membrane. Pipes rest on a polycarbonate resin roller and a stainless-steel axle assembly that is attached to a polycarbonate resin base via 1/2 inch stainless-steel all-thread. The height of the roller assembly can be adjusted down on the all-thread to meet project specific heights and slopes.
- Product Performance:** The polycarbonate roller serves to keep the pipestand system directly beneath the pipe without binding. It also allows for some lateral expansion of the pipe system. All base edges are gently rounded to prevent gouging the roof membrane.
- Compatibility:** The 5-RAH-8 and 5-RAH-12 pipestands are recommended and are compatible to use with all current deck types and with all commonly used built-up and single-ply roofing membranes where roof-mounted pipes occur.
- Load Weight:** Maximum load weight on the 5-RAH-8 and the 5-RAH-12 may not exceed 335 pounds per pipestand.
- Composition and Materials:** The pipestand consists of three major components: (1) A polycarbonate resin deck base, (2) stainless-steel vertical all-thread with hot-dip galvanized hardware, and (3) a polycarbonate roller and stainless-steel axle assembly. Carbon black is added to the polycarbonate resin for UV-resistance and protection.
- Size:** The 5-RAH-8 and 5-RAH-12 have a 9 x 15-1/4 inch deck base and a roller assembly that can carry up to an 8-1/2 inch maximum outside diameter pipe (including insulation). The 5-RAH-8 and 5-RAH-12 supports are optimally designed to carry a 5 inch pipe. The 5-RAH-8 can adjust from the factory-set maximum height of 8 inches down to 3-3/4 inches from the deck to the bottom of the pipe. The 5-RAH-12 can adjust from the factory-set maximum height of 12 inches down to 3-3/4 inches from the deck to the bottom of the pipe.
- Installation:** To install the 5-RAH series pipestand, (1) center the pipestand beneath the pipe so that the pipe will rest centered directly on the roller. (2) Set the pipe in the pipestand without dropping or causing any undue impact. (3) An additional sheet of roofing material, or a MIRO Support Pad should be installed beneath the pipestand. For built up roofs, clear all loose aggregate from an area 2 inches outside each base footprint and then follow the installation directions outlined above. Care should be taken to install each pipestand so it supports a proportional and equal amount of weight with all other pipestands.  
  
In addition, the pipe may be secured to the pipestand by using a MIRO Pipe Guide. The pipe guide is attached to the stand by removing the nuts from the top of the support, placing the pipe guide on the all-thread and re-installing the nuts. **Note:** the pipe guide should not be rigidly-attached to the pipe in the pipestand, thus allowing the supported pipe to expand and contract without binding.
- Spacing:** Manufacturer's recommended spacing is not to exceed 10 foot centers depending upon the load. Make certain each pipestand is properly elevated and adjusted to ensure even-load distribution to all pipestands. Support spacing is not to exceed the maximum spacing required in the pipe specifications, where applicable.
- Availability:** The 5-RAH-8 and 5-RAH-12 pipestands are marketed throughout the United States through representatives and distributors.
- Maintenance:** Normal maintenance is not required. Semi-annual inspection is required to check pipestand position and set pipe alignment, check proper weight distribution, and to correct improper installation that may cause pipestand damage or failures.
- Technical Services:** Please call MIRO INDUSTRIES, INC: (800) 768-6978 or visit our website [www.miroind.com](http://www.miroind.com) for technical information and for graphic and CAD drawing downloads.

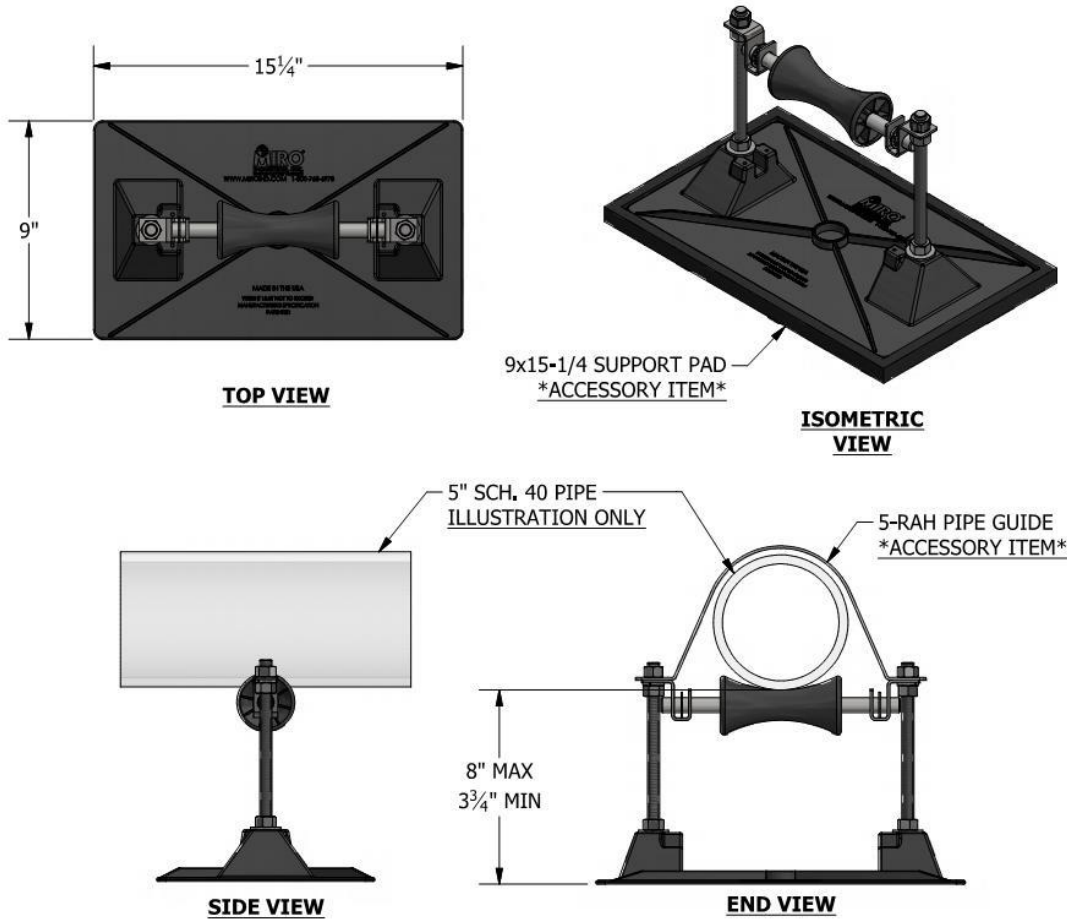

**ACCESSORIES**

- Refer to 5-RAH Pipe Guide specification for available sizes.
- 9" x 15 1/4" Support pad
- Eternabond® 2-sided tape

**PRODUCT DESCRIPTION**

A "roller-bearing" pipe support used to support roof-mounted gas pipes, electrical conduit, solar piping and other mechanical piping. Unique design absorbs thermal expansion and contraction of pipes thus preventing damage to the roof membrane. Pipes rest on a self-lubricating polycarbonate resin roller and a stainless steel axle.

**KEY INFORMATION**

- Optimally designed for a 5" pipe.
- Maximum pipe OD (with insulation) is 8-1/2".
- Adjustable from the factory set maximum height of 8" down to a minimum height of 3-3/4".
- Maximum load is 335 lbs. (3.0 psi) Make certain each pipe support is properly elevated to evenly distribute weight at all pipe support locations.
- Unit weight: 3.87 lbs.
- 7 per case, 29 lbs. per case, (DW=36 lbs.)
- Recommended spacing is not to exceed 10' centers depending upon the load.
- Base Material: Polycarbonate
- Roller Material: Polycarbonate
- 1/2" all-thread and 5/8" axle are stainless steel
- All other metal parts are hot-dip galvanized

The information contained in this drawing is the sole property of MIRO Industries, Inc. Any reproduction in part or as a whole without written permission of MIRO Industries, Inc. is prohibited.	DATE:	5-RAH-8
	JAN 2019	

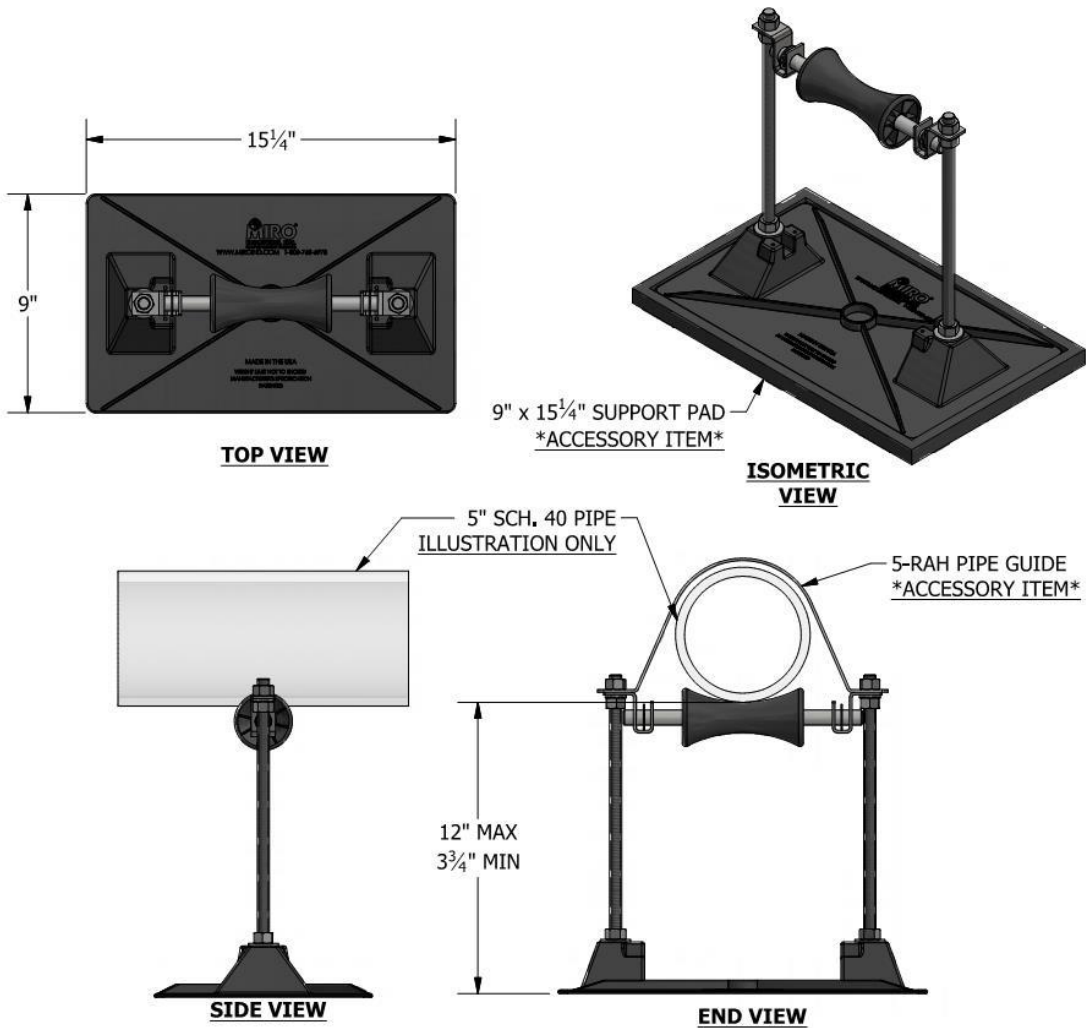

#### ACCESSORIES

- Refer to 5-RAH Pipe Guide specification for available sizes.
- 9" x 15 $\frac{1}{4}$ " Support pad
- Eternabond® 2-sided tape

#### PRODUCT DESCRIPTION

A "roller-bearing" pipe support used to support roof-mounted gas pipes, electrical conduit, solar piping and other mechanical piping. Unique design absorbs thermal expansion and contraction of pipes thus preventing damage to the roof membrane. Pipes rest on a self-lubricating polycarbonate resin roller and a stainless steel axle.

#### KEY INFORMATION

- Optimally designed for a 5" pipe.
- Maximum pipe OD (with insulation) is 8-1/2".
- Adjustable from the factory set maximum height of 12" down to a minimum height of 3-3/4".
- Maximum load is 335 lbs. (3,0 psi) Make certain each pipe support is properly elevated to evenly distribute weight at all pipe support locations.
- Unit weight: 4.32 lbs.
- 6 per case, 26 lbs. per case, (DW=36 lbs.)
- Recommended spacing is not to exceed 10' centers depending upon the load.
- Base Material: Polycarbonate
- Roller Material: Polycarbonate
- 1/2" all-thread and 5/8" axle are stainless steel
- All other metal parts are hot-dip galvanized

The information contained in this drawing is the sole property of MIRO Industries, Inc. Any reproduction in part or as a whole without written permission of MIRO Industries, Inc. is prohibited.

DATE:  
JAN 2019

5-RAH-12

**Optimal Pipe Size:**  
Up to a 6" Pipe or  
8-1/2" Max OD

## Product Data Sheet

# 6-RAH-8, 6-RAH-12

- Product Name:** Roller Support 6-RAH-8 and 6-RAH-12. **NOTE:** Roller Support pipestand model numbers correspond to the optimal pipe sizes for the support. With variation in pipe wall thickness and actual outside dimensions, or where the pipe is insulated, the 6-RAH-8 and 6-RAH-12 can accommodate up to an 8-1/2 inch maximum outside diameter. The 6-RAH series supports will hold up to all nominal and customary 6 inch and smaller pipe sizes. Larger pipe with up to a maximum outside diameter of 8-1/2 inches may be placed on the 6-RAH series supports at reduced support spacing as approved by MIRO Industries.
- Manufacturer:** MIRO INDUSTRIES, INC. Phone: (800) 768-6978  
844 South 430 West, Suite 100, Fax: (800) 440-7958  
Heber City, Utah 84032
- Product Description:** A "roller-bearing" pipe support used to support roof-mounted gas pipes, electrical conduit, solar piping, or other mechanical piping. The unique design absorbs thermal expansion and contraction of pipes, thus preventing damage to the roof membrane. Pipes rest on a polycarbonate resin roller and a stainless-steel axle assembly that is attached to a polycarbonate resin base via 1/2 inch stainless-steel all-thread. The height of the roller assembly can be adjusted down on the all-thread to meet project specific heights and slopes.
- Product Performance:** The polycarbonate roller serves to keep the pipestand system directly beneath the pipe without binding. It also allows for some lateral expansion of the pipe system. All base edges are gently rounded to prevent gouging the roof membrane.
- Compatibility:** The 6-RAH-8 and 6-RAH-12 pipestands are recommended and are compatible to use with all current deck types and with all commonly used built-up and single-ply roofing membranes where roof-mounted pipes occur.
- Load Weight:** Maximum load weight on the 6-RAH-8 and the 6-RAH-12 may not exceed 578 pounds per pipestand.
- Composition and Materials:** The pipestand consists of three major components: (1) A polycarbonate resin deck base, (2) stainless-steel vertical all-thread with hot-dip galvanized hardware, and (3) a polycarbonate roller and stainless-steel axle assembly. Carbon black is added to the polycarbonate resin for UV-resistance and protection.
- Size:** The 6-RAH-8 and 6-RAH-12 have a 16 x 18 inch polycarbonate deck base. All 6-RAH series supports have a roller assembly that can carry up to an 8-1/2 inch maximum outside diameter pipe (including insulation). The 6-RAH series supports are optimally designed to carry a 6 inch pipe. The 6-RAH-8 and 6-RAH-12 can adjust from the factory-set maximum height of 8 inches and 12 inches respectively, down to 4-3/8 inches from the deck to the bottom of the pipe.
- Installation:** To install the 6-RAH series pipestand, (1) center the pipestand beneath the pipe so that the pipe will rest centered directly on the roller. (2) Set the pipe in the pipestand without dropping or causing any undue impact. (3) An additional sheet of roofing material, or a MIRO Support Pad should be installed beneath the pipestand. For built up roofs, clear all loose aggregate from an area 2 inches outside each base footprint, and then follow the installation directions outlined above. Care should be taken to install each pipestand, so it supports a proportional and equal amount of weight with all other pipestands.  
  
In addition, the pipe may be secured to the pipestand by using a MIRO Pipe Guide. The pipe guide is attached to the stand by removing the nuts from the top of the support, placing the pipe guide on the all-thread and re-installing the nuts. **Note:** the pipe guide should not be rigidly-attached to the pipe in the pipestand, thus allowing the supported pipe to expand and contract without binding.
- Spacing:** Manufacturer's recommended spacing is not to exceed 10 foot centers depending upon the load. Make certain each pipestand is properly elevated and adjusted to ensure even-load distribution to all pipestands. Support spacing is not to exceed the maximum spacing required in the pipe specifications, where applicable.
- Availability:** The 6-RAH series pipestands are marketed throughout the United States through representatives and distributors.
- Maintenance:** Normal maintenance is not required. Semi-annual inspection is required to check pipestand position and set pipe alignment, check proper weight distribution, and to correct improper installation which may cause pipestand damage or failures.
- Technical Services:** Please call MIRO INDUSTRIES, INC: (800) 768-6978 or visit our website [www.miroind.com](http://www.miroind.com) for technical information and for graphic and CAD drawing downloads.



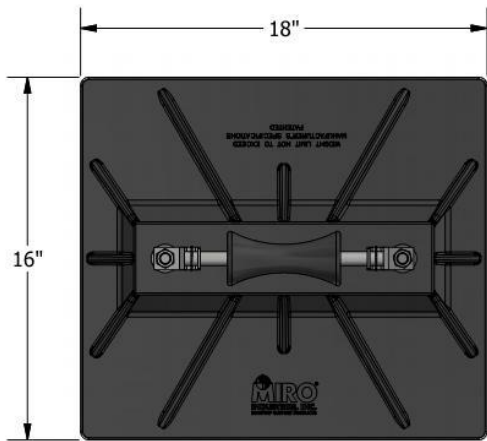

**TOP VIEW**

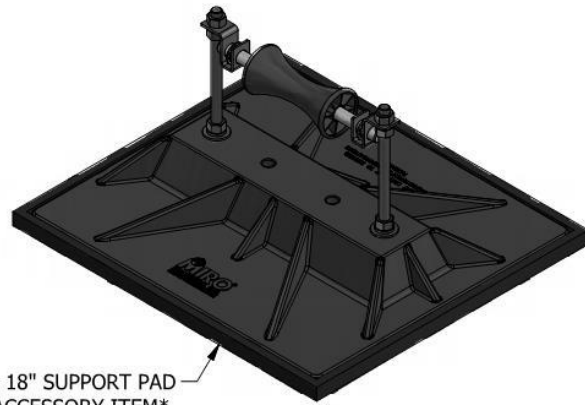

**ISOMETRIC VIEW**

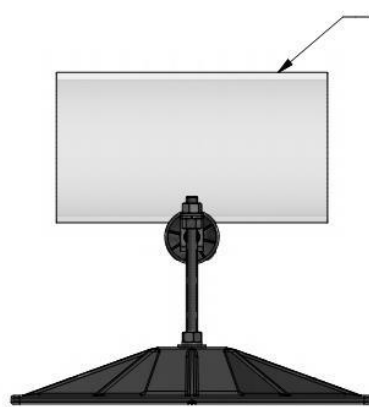

**SIDE VIEW**

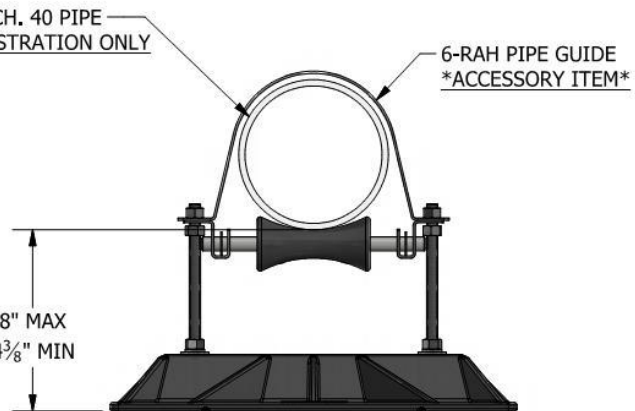

**END VIEW**

**ACCESSORIES**

- Refer to 6-RAH Pipe Guide specification for available sizes.
- 16" x 18" Support pad
- Eternabond® 2-sided tape

**PRODUCT DESCRIPTION**

A "roller-bearing" pipe support used to support roof-mounted gas pipes, electrical conduit, solar piping and other mechanical piping. Unique design absorbs thermal expansion and contraction of pipes thus preventing damage to the roof membrane. Pipes rest on a self-lubricating polycarbonate resin roller and a stainless steel axle.

**KEY INFORMATION**

- Optimally designed for a 6" pipe.
- Maximum pipe OD (with insulation) is 8-1/2".
- Adjustable from the factory set maximum height of 8" down to a minimum height of 4-3/8".
- Maximum load is 578 lbs. (3.0 psi) Make certain each pipe support is properly elevated to evenly distribute weight at all pipe support locations.
- Unit weight: 7.02 lbs.
- 4 per case, 33 lbs. per case, (DW=42 lbs.)
- Recommended spacing is not to exceed 10' centers depending upon the load.
- Base Material: Polycarbonate
- Roller Material: Polycarbonate
- 1/2" all-thread and 5/8" axle are stainless steel
- All other metal parts are hot-dip galvanized

The information contained in this drawing is the sole property of MIRO Industries, Inc. Any reproduction in part or as a whole without written permission of MIRO Industries, Inc. is prohibited.	DATE:	6-RAH-8
	JAN 2019	

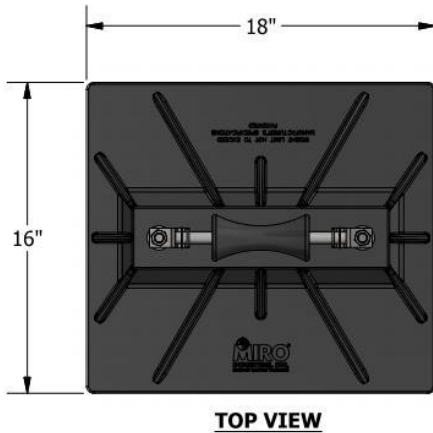

**TOP VIEW**

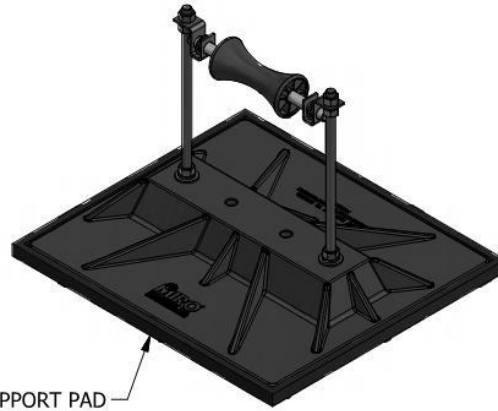

16" x 18" SUPPORT PAD  
\*ACCESSORY ITEM\*

**ISOMETRIC VIEW**



**SIDE VIEW**

6" SCH. 40 PIPE  
ILLUSTRATION ONLY

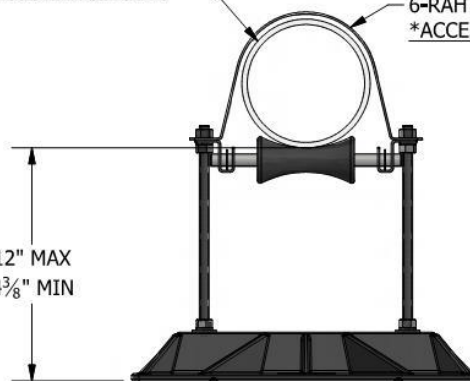

12" MAX  
4<sup>3</sup>/<sub>8</sub>" MIN

**END VIEW**

**ACCESSORIES**

- Refer to 6-RAH Pipe Guide specification for available sizes.
- 16" x 18" Support pad
- Eternabond® 2-sided tape

**PRODUCT DESCRIPTION**

A "roller-bearing" pipe support used to support roof-mounted gas pipes, electrical conduit, solar piping and other mechanical piping. Unique design absorbs thermal expansion and contraction of pipes thus preventing damage to the roof membrane. Pipes rest on a self-lubricating polycarbonate resin roller and a stainless steel axle.

**KEY INFORMATION**

- Optimally designed for a 6" pipe.
- Maximum pipe OD (with insulation) is 8-1/2".
- Adjustable from the factory set maximum height of 12" down to a minimum height of 4-3/8".
- Maximum load is 578 lbs. (3.0 psi) Make certain each pipe support is properly elevated to evenly distribute weight at all pipe support locations.
- Unit weight: 7.47 lbs.
- 4 per case, 35 lbs. per case, (DW=47 lbs.)
- Recommended spacing is not to exceed 10' centers depending upon the load.
- Base Material: Polycarbonate
- Roller Material: Polycarbonate
- 1/2" all-thread and 5/8" axle are stainless steel
- All other metal parts are hot-dip galvanized

The information contained in this drawing is the sole property of MIRO Industries, Inc. Any reproduction in part or as a whole without written permission of MIRO Industries, Inc. is prohibited.

DATE:  
JAN 2019

6-RAH-12

**Optimal Pipe Size:**  
Up to a 6" Pipe or  
8-1/2" Max OD

## Product Data Sheet

# 6-RAH-8 SS and 6-RAH-12 SS

- Product Name:** Roller Support 6-RAH-8 SS and 6-RAH-12 SS. **NOTE:** Roller Support pipestand model numbers correspond to the optimal pipe sizes for the support. With variation in pipe wall thickness and actual outside dimensions, or where the pipe is insulated, the 6-RAH-8 and 6-RAH-12 can accommodate up to an 8-1/2 inch maximum outside diameter. The 6-RAH series supports will hold up to all nominal and customary 6 inch and smaller pipe sizes. Larger pipe with up to a maximum outside diameter of 8-1/2 inches may be placed on the 6-RAH series supports at reduced support spacing as approved by MIRO Industries.
- Manufacturer:** MIRO INDUSTRIES, INC.  
844 South 430 West, Suite 100,  
Heber City, Utah 84032  
Phone: (800) 768-6978  
Fax: (800) 440-7958
- Product Description:** A "roller-bearing" pipe support used to support roof-mounted gas pipes, electrical conduit, solar piping, or other mechanical piping. The unique design absorbs thermal expansion and contraction of pipes, thus preventing damage to the roof membrane. Pipes rest on a polycarbonate resin roller and a stainless-steel axle assembly that is attached to a stainless-steel base via 1/2 inch stainless-steel all-thread. The height of the roller assembly can be adjusted down on the all-thread to meet project specific heights and slopes.
- Product Performance:** The polycarbonate roller serves to keep the pipestand system directly beneath the pipe without binding. It also allows for some lateral expansion of the pipe system. All base edges are gently rounded to prevent gouging the roof membrane.
- Compatibility:** The 6-RAH-8 SS and 6-RAH-12 SS pipestands are recommended and are compatible to use with all current deck types and with all commonly used built-up and single-ply roofing membranes where roof-mounted pipes occur.
- Load Weight:** Maximum load weight on the 6-RAH-8 SS and the 6-RAH-12 SS may not exceed 524 pounds per pipestand.
- Composition and Materials:** The pipestand consists of three major components: (1) A stainless-steel deck base, (2) stainless-steel vertical all-thread with hot-dip galvanized hardware, and (3) a polycarbonate roller and stainless-steel axle assembly. Carbon black is added to the polycarbonate resin for UV-resistance and protection.
- Size:** The 6-RAH-8 SS and 6-RAH-12 SS have a 12 x 16 inch stainless-steel deck base. All 6-RAH series supports have a roller assembly that can carry up to an 8-1/2 inch maximum outside diameter pipe (including insulation). The 6-RAH series supports are optimally designed to carry a 6 inch pipe. The 6-RAH-8 SS and the 6-RAH-12 SS can adjust from the factory-set maximum height of 8 inches and 12 inches respectively, down to 2-7/8 inches from the deck to the bottom of the pipe.
- Installation:** To install the 6-RAH series pipestand, (1) center the pipestand beneath the pipe so that the pipe will rest centered directly on the roller. (2) Set the pipe in the pipestand without dropping or causing any undue impact. (3) An additional sheet of roofing material, or a MIRO Support Pad should be installed beneath the pipestand. For built up roofs, clear all loose aggregate from an area 2 inches outside each base footprint, and then follow the installation directions outlined above. Care should be taken to install each pipestand, so it supports a proportional and equal amount of weight with all other pipestands.  
  
In addition, the pipe may be secured to the pipestand by using a MIRO Pipe Guide. The pipe guide is attached to the stand by removing the nuts from the top of the support, placing the pipe guide on the all-thread and re-installing the nuts. **Note:** the pipe guide should not be rigidly-attached to the pipe in the pipestand, thus allowing the supported pipe to expand and contract without binding.
- Spacing:** Manufacturer's recommended spacing is not to exceed 10 foot centers depending upon the load. Make certain each pipestand is properly elevated and adjusted to ensure even-load distribution to all pipestands. Support spacing is not to exceed the maximum spacing required in the pipe specifications, where applicable.
- Availability:** The 6-RAH series pipestands are marketed throughout the United States through representatives and distributors.
- Maintenance:** Normal maintenance is not required. Semi-annual inspection is required to check pipestand position and set pipe alignment, check proper weight distribution, and to correct improper installation which may cause pipestand damage or failures.
- Technical Services:** Please call MIRO INDUSTRIES, INC: (800) 768-6978 or visit our website [www.miroind.com](http://www.miroind.com) for technical information and for graphic and CAD drawing downloads.

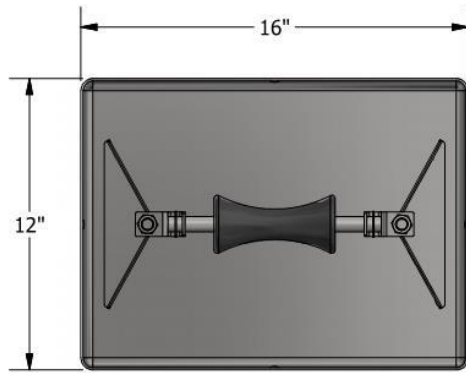

**TOP VIEW**

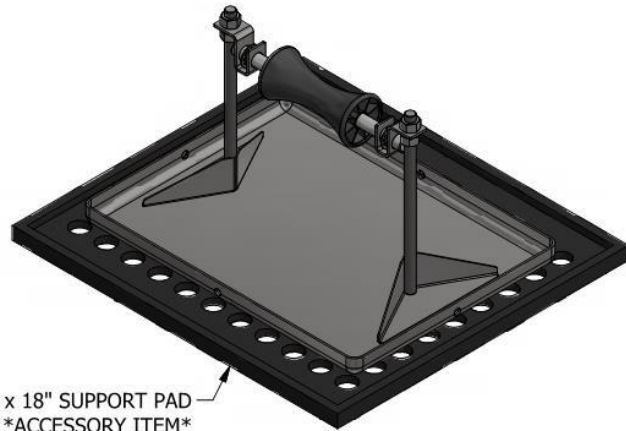

**ISOMETRIC VIEW**

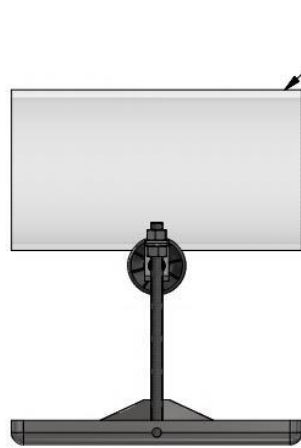

**SIDE VIEW**

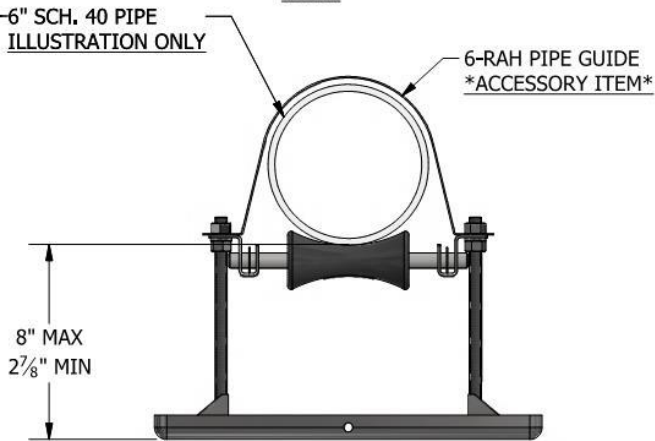

**FRONT VIEW**

**ACCESSORIES**

- Refer to 6-RAH Pipe Guide specification for available sizes.
- 16" x 18" Support pad
- Eternabond® 2-sided tape

**PRODUCT DESCRIPTION**

A "roller-bearing" pipe support used to support roof-mounted gas pipes, electrical conduit, solar piping and other mechanical piping. Unique design absorbs thermal expansion and contraction of pipes thus preventing damage to the roof membrane. Pipes rest on a self-lubricating polycarbonate resin axle and roller.

**KEY INFORMATION**

- Optimally designed for a 6" pipe.
- Maximum pipe OD (with insulation) is 8-1/2".
- Adjustable from the factory set maximum height of 8" down to a minimum height of 2-7/8".
- Maximum load is 524 lbs. (3.0 psi) Make certain each pipe support is properly elevated to evenly distribute weight at all pipe support locations.
- Unit weight: 9.74 lbs.
- Recommended spacing is not to exceed 10' centers depending upon the load.
- Base Material: Stainless Steel
- Roller Material: Polycarbonate
- 1/2" all-thread and 5/8" axle are stainless steel
- All other metal parts are hot-dip galvanized

The information contained in this drawing is the sole property of MIRO Industries, Inc. Any reproduction in part or as a whole without written permission of MIRO Industries, Inc. is prohibited.

DATE:  
JAN 2019

6-RAH-8 SS



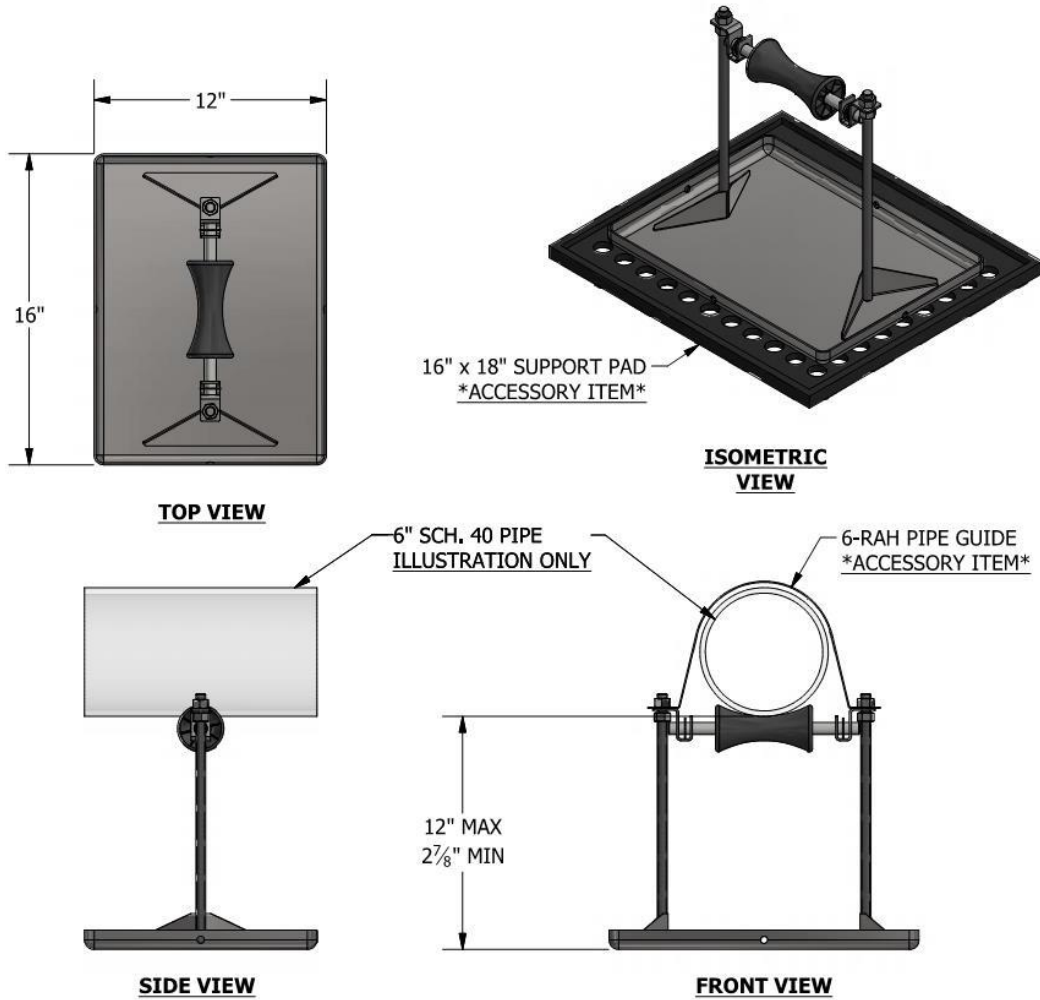

**ACCESSORIES**

- Refer to 6-RAH Pipe Guide specification for available sizes.
- 16" x 18" Support pad
- Eternabond® 2-sided tape

**PRODUCT DESCRIPTION**

A "roller-bearing" pipe support used to support roof-mounted gas pipes, electrical conduit, solar piping and other mechanical piping. Unique design absorbs thermal expansion and contraction of pipes thus preventing damage to the roof membrane. Pipes rest on a self-lubricating polycarbonate resin axle and roller.

**KEY INFORMATION**

- Optimally designed for a 6" pipe.
- Maximum pipe OD (with insulation) is 8-1/2".
- Adjustable from the factory set maximum height of 12" down to a minimum height of 2-7/8",
- Maximum load is 524 lbs. (3.0 psi) Make certain each pipe support is properly elevated to evenly distribute weight at all pipe support locations.
- Unit weight: 10.20 lbs.
- Recommended spacing is not to exceed 10' centers depending upon the load.
- Base Material: Stainless Steel
- Roller Material: Polycarbonate
- 1/2" all-thread and 5/8" axle are stainless steel
- All other metal parts are hot-dip galvanized

The information contained in this drawing is the sole property of MIRO Industries, Inc. Any reproduction in part or as a whole without written permission of MIRO Industries, Inc. is prohibited.	DATE:	6-RAH-12 SS
	JAN 2019	

**Optimal Pipe Size:**  
Up to a 10" Pipe or  
13" Max OD

## Product Data Sheet

# 10-RAH-8 and 10-RAH-18

- Product Name:** Roller Support 10-RAH-8 and 10-RAH-18. **NOTE:** Roller Support pipestand model numbers correspond to the optimal pipe sizes for the support. With variation in pipe wall thickness and actual outside dimensions, or where the pipe is insulated, the 10-RAH-8 and 10-RAH-18 can accommodate up to a 13 inch maximum outside diameter. The 10-RAH-8 and 10-RAH-18 will hold up to all nominal and customary 10 inch and smaller pipe sizes. Larger pipe with up to a maximum outside diameter of 13 inches may be placed on the Model 10-RAH-8 and 10-RAH-18 at reduced support spacing as approved by MIRO Industries.
- Manufacturer:** MIRO INDUSTRIES, INC.  
844 South 430 West, Suite 100,  
Heber City, Utah 84032  
Phone: (800) 768-6978  
Fax: (800) 440-7958
- Product Description:** A "roller-bearing" pipe support used to support roof-mounted gas pipes, electrical conduit, solar piping, or other mechanical piping. The unique design absorbs thermal expansion and contraction of pipes, thus preventing damage to the roof membrane. Pipes rest on a composite rubber roller and a stainless-steel axle assembly that is attached to a polycarbonate resin base via 5/8 inch stainless-steel all-thread. The height of the roller assembly can be adjusted down on the all-thread to meet project specific heights and slopes.
- Product Performance:** The composite rubber roller serves to keep the pipestand system directly beneath the pipe without binding. It also allows for some lateral expansion of the pipe system. All base edges are gently rounded to prevent gouging the roof membrane.
- Compatibility:** The 10-RAH-8 and 10-RAH-18 pipestands are recommended and are compatible to use with all current deck types and with all commonly used built-up and single-ply roofing membranes where roof-mounted pipes occur.
- Load Weight:** Maximum load weight on the 10-RAH-8 may not exceed 960 pounds per pipestand. Maximum load weight on the 10-RAH-18 may not exceed 803 pounds per pipestand.
- Composition and Materials:** The pipestand consists of three major components: (1) A polycarbonate resin deck base, (2) stainless-steel vertical all-thread with hot-dip galvanized hardware, and (3) a composite rubber roller and stainless-steel axle assembly. Carbon black is added to the polycarbonate resin for UV-resistance and protection.
- Size:** The 10-RAH-8 and 10-RAH-18 have a 19 x 23 inch deck base and a roller assembly that can carry up to a 13 inch maximum outside diameter pipe (including insulation). The 10-RAH-8 and 10-RAH-18 supports are optimally designed to carry a 10 inch pipe. The 10-RAH-8 and 10-RAH-18 can adjust from the factory-set maximum height of 8 inches and 17-3/4 inches respectively down to 6 inches from the deck to the bottom of the pipe.
- Installation:** To install the 10-RAH series pipestand, (1) center the pipestand beneath the pipe so that the pipe will rest centered directly on the roller. (2) Set the pipe in the pipestand without dropping or causing any undue impact. (3) An additional sheet of roofing material, or a MIRO Support Pad should be installed beneath the pipestand. For built up roofs, clear all loose aggregate from an area 2 inches outside each base footprint and then follow the installation directions outlined above. Care should be taken to install each pipestand, so it supports a proportional and equal amount of weight with all other pipestands.  
  
In addition, the pipe may be secured to the pipestand by using a MIRO Pipe Guide. The pipe guide is attached to the stand by removing the nuts from the top of the support, placing the pipe guide on the all-thread and re-installing the nuts. **Note:** the pipe guide should not be rigidly-attached to the pipe in the pipestand, thus allowing the supported pipe to expand and contract without binding.
- Spacing:** Manufacturer's recommended spacing is not to exceed 10 foot centers depending upon the load. Make certain each pipestand is properly elevated and adjusted to ensure even-load distribution to all pipestands. Support spacing is not to exceed the maximum spacing required in the pipe specifications, where applicable.
- Availability:** The 10-RAH-8 and 10-RAH-18 pipestands are marketed throughout the United States through representatives and distributors.
- Maintenance:** Normal maintenance is not required. Semi-annual inspection is required to check pipestand position and set pipe alignment, check proper weight distribution, and to correct improper installation which may cause pipestand damage or failures.
- Technical Services:** Please call MIRO INDUSTRIES, INC: (800) 768-6978 or visit our website [www.miroind.com](http://www.miroind.com) for technical information and for graphic and CAD drawing downloads.



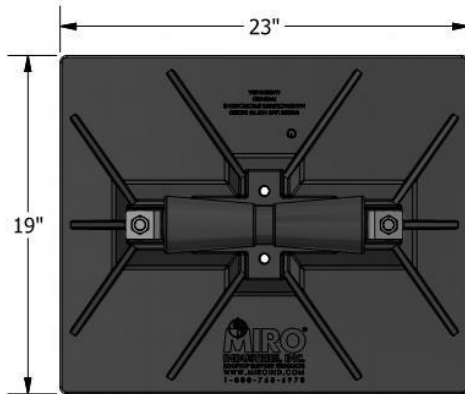

**TOP VIEW**

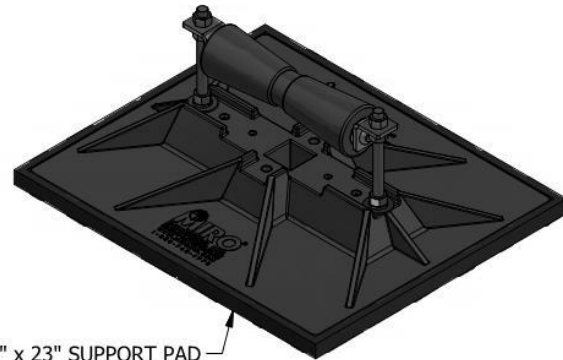

19" x 23" SUPPORT PAD  
\*ACCESSORY ITEM\*

**ISOMETRIC VIEW**

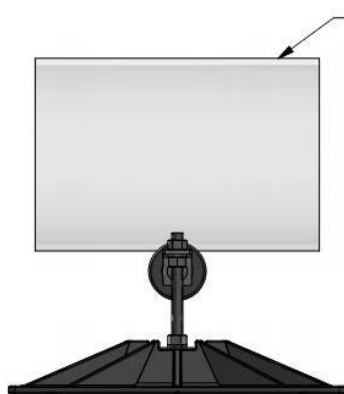

**SIDE VIEW**

10" SCH. 40 PIPE  
ILLUSTRATION ONLY

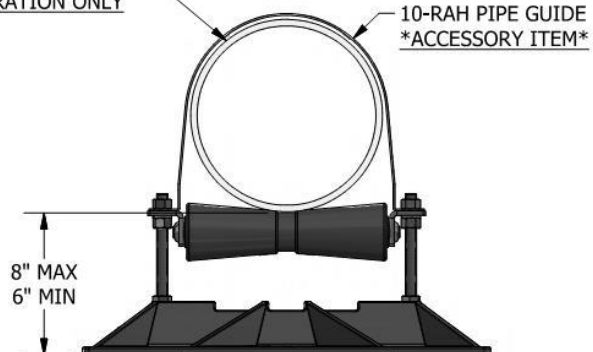

10-RAH PIPE GUIDE  
\*ACCESSORY ITEM\*

8" MAX  
6" MIN

**END VIEW**

**ACCESSORIES**

- 10-RAH Pipe Guides are built to order.
- 19" x 23" Support pad
- Eternabond® 2-sided tape.

**PRODUCT DESCRIPTION**

A "roller-bearing" pipe support used to support roof-mounted gas pipes, electrical conduit, solar piping and other mechanical piping.

Unique design absorbs thermal expansion and contraction of pipes thus preventing damage to the roof membrane. Pipes rest on a rubber roller and a stainless steel axle.

**KEY INFORMATION**

- Optimally designed for a 10" pipe.
- Maximum pipe OD (with insulation) is 13".
- Adjustable from the factory set maximum height of 8" down to a minimum height of 6".
- Maximum load is 960 lbs. (3,0 psi) Make certain each pipe support is properly elevated to evenly distribute weight at all pipe support locations.
- Unit weight: 14.56 lbs.
- Recommended spacing is not to exceed 10' centers depending upon the load.
- Base Material: Polycarbonate
- Roller Material: Composite Rubber
- 5/8" all-thread and axle are stainless steel
- All other metal parts are hot-dip galvanized

The information contained in this drawing is the sole property of MIRO Industries, Inc. Any reproduction in part or as a whole without written permission of MIRO Industries, Inc. is prohibited.

DATE:  
JAN 2019

10-RAH-8

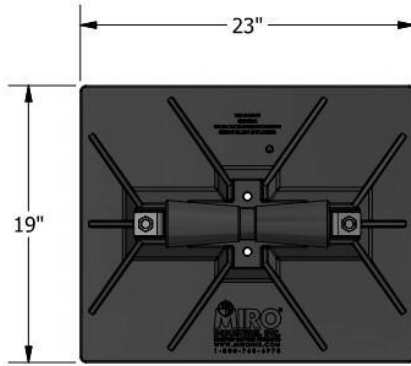

**TOP VIEW**

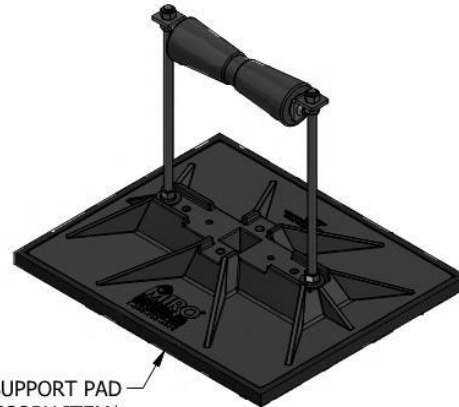

19" x 23" SUPPORT PAD  
\*ACCESSORY ITEM\*

**ISOMETRIC VIEW**

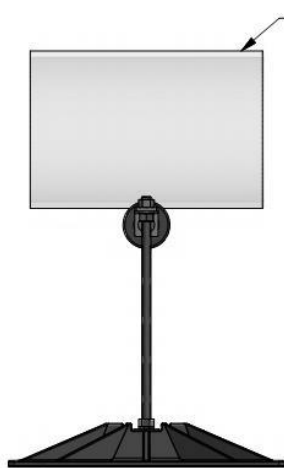

**SIDE VIEW**

10" SCH. 40 PIPE  
ILLUSTRATION ONLY

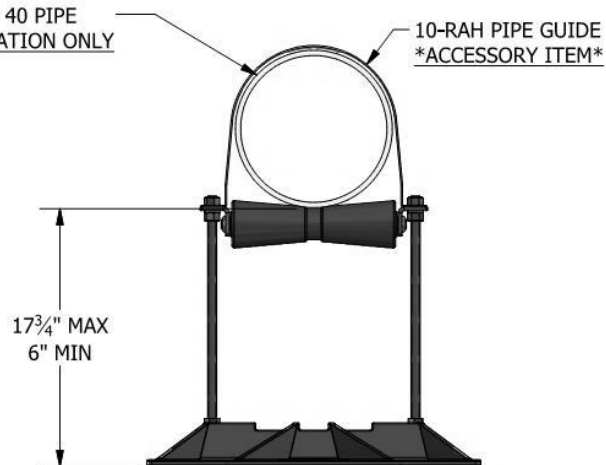

**END VIEW**

10-RAH PIPE GUIDE  
\*ACCESSORY ITEM\*

17<sup>3</sup>/<sub>4</sub>" MAX  
6" MIN

**ACCESSORIES**

- 10-RAH Pipe Guides are built to order.
- 19" x 23" Support pad
- Eternabond® 2-sided tape.

**PRODUCT DESCRIPTION**

A "roller-bearing" pipe support used to support roof-mounted gas pipes, electrical conduit, solar piping and other mechanical piping.

Unique design absorbs thermal expansion and contraction of pipes thus preventing damage to the roof membrane.

Pipes rest on a rubber roller and a stainless steel axle.

**KEY INFORMATION**

- Optimally designed for a 10" pipe.
- Maximum pipe OD (with insulation) is 13".
- Adjustable from the factory set maximum height of 17-3/4" down to a minimum height of 6".
- Maximum load is 803 lbs. (All-thread capacity) Make certain each pipe support is properly elevated to evenly distribute weight at all pipe support locations.
- Unit weight: 15.96 lbs.
- Recommended spacing is not to exceed 10' centers depending upon the load.
- Base Material: Polycarbonate
- Roller Material: Composite Rubber
- 5/8" all-thread and axle are stainless steel
- All other metal parts are hot-dip galvanized

The information contained in this drawing is the sole property of MIRO Industries, Inc. Any reproduction in part or as a whole without written permission of MIRO Industries, Inc. is prohibited.	DATE:	10-RAH-18
	JAN 2019	

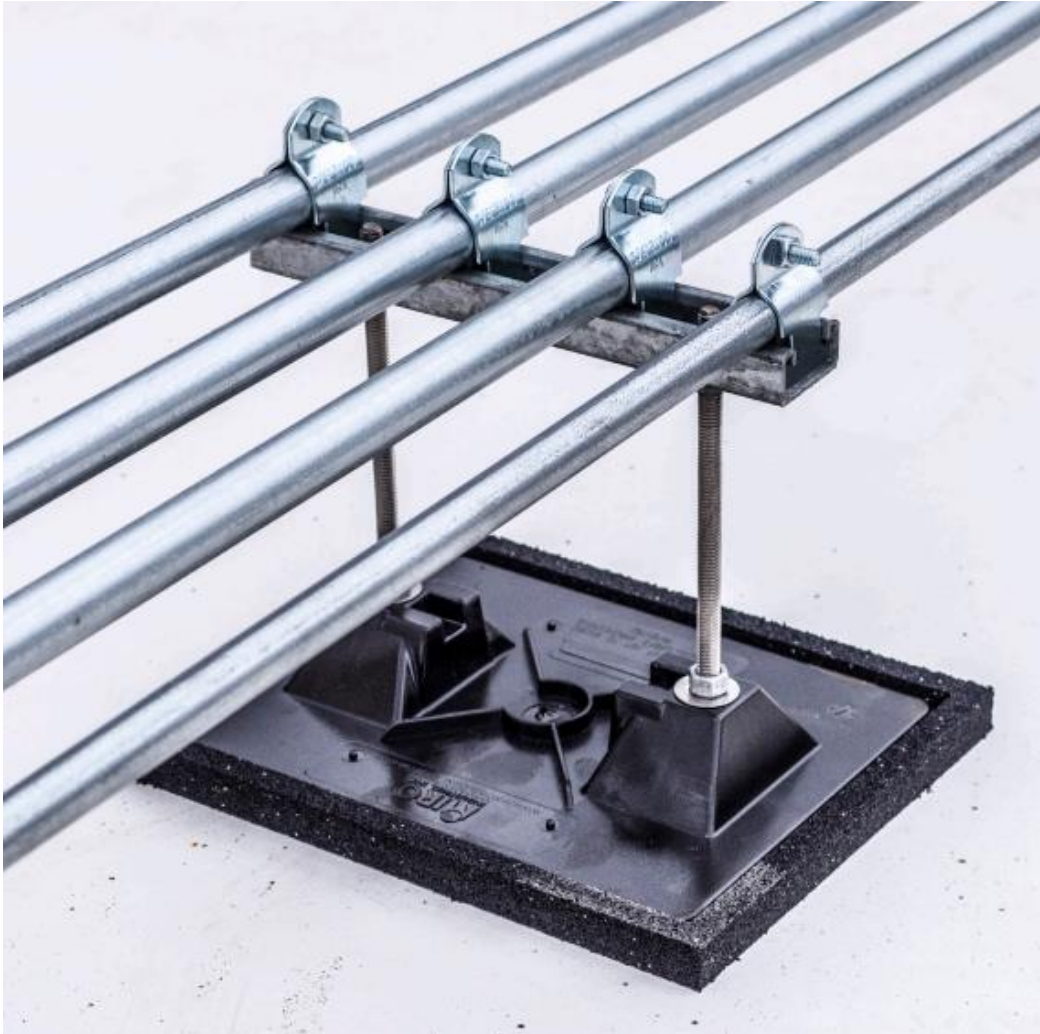

## **STRUT SUPPORTS**

Strut Series Supports are built to accommodate electrical conduit, solar lines, or any other mechanical piping where there is a single, multiple or combination of lines. These models can be set up in widths from an 8 inch single-base, up to a 48 inch four-base off-the-shelf model or built into custom configurations. With some Strut Series models able to carry loads up to 960 pounds, and at heights up to 18 inch above the roof, practically any need can be met for a rooftop layout.

All bases are either UV-stable polycarbonate or stainless-steel and are designed with the adequate footprint to balance their maximum loads. All hardware is hot-dip galvanized, or optionally available in stainless-steel. For added security, pipe/conduit clamps can be provided upon request.

**Strut Size:**  
8" Strut  
1-5/8" x 13/16"

## Product Data Sheet

# 8-Base Strut-2, 8-Base Strut-5, 8-Base Strut-8, 8-Base Strut-12,

1. **Product Name:** 8-Base Strut-2, 8-Base Strut-5, 8-Base Strut-8 and 8-Base Strut-12
2. **Manufacturer:** MIRO INDUSTRIES, INC.  
844 South 430 West, Suite 100,  
Heber City, Utah 84032  
Phone: (800) 768-6978  
Fax: (800) 440-7958
3. **Product Description:** A rooftop support with "strut" used to support roof-mounted electrical conduit, solar piping, gas pipes, or other mechanical piping. Pipes rest on a length of hot-dip galvanized steel strut. The pipe support base is made of polycarbonate resin, and all other metal parts are made of hot-dip galvanized or stainless-steel.
4. **Product Performance:** The base is gently rounded to allow movement upon the roof to prevent gouging the roof membrane. Each support offers the following clearances above the roof:
  - 8-Base Strut-2 has a fixed height of 2-1/2 inches.
  - 8-Base Strut-5 has a factory-set maximum height of 5-3/8 inches with adjustability down to 3-1/2 inches.
  - 8-Base Strut-8 has a factory-set maximum height of 8-7/8 inches with adjustability down to 3-1/2 inches.
  - 8-Base Strut-12 has a factory-set maximum height of 12-7/8 inches with adjustability down to 3-1/2 inches.

More than one conduit or pipe may be ganged on the pipe support and attached with typical pipe clamps or clips, so long as the total load weight per support does not exceed recommended weight limit.
5. **Compatibility:** Base Strut Pipestands are recommended and are compatible to use with all current deck types and with all commonly used built-up and single-ply roofing membranes where roof-mounted pipes occur.
6. **Load Weight:** Maximum load weight may not exceed 172 pounds on each of the 8-Base Strut series pipestands.
7. **Composition and Materials:** The pipestand consists of three major components: (1) A polycarbonate resin deck base, (2) 3/8 inch diameter stainless-steel all thread with hot-dip galvanized hardware, and (3) an 8 inch piece of 1-5/8 x 13/16 inch hot-dip galvanized strut. Carbon black is added to the polycarbonate resin for UV-resistance and protection.
8. **Size:** The 8-Base Strut series pipestands have a 7-1/2 x 10 inch polycarbonate deck base and an 8 inch piece of 1-5/8 x 13/16 inch hot-dip galvanized strut. The 8-Base Strut models provide height adjustability as outlined above.
9. **Installation:** (1) Center the pipestand beneath the pipe so that the strut allows the pipe to be positioned squarely over the pipestand. (2) Adjust the pipestand to the desired height and ensure load is evenly distributed with other pipestands. Make certain the strut is level. (3) Set the pipe on the pipestand without dropping or causing any undue impact.

An additional sheet of roofing material, a traffic pad, or a MIRO Support Pad should be installed beneath the pipestand. For built up roofs, clear all loose aggregate from an area 2 inches outside each base footprint and then follow the installation directions outlined above. Care should be taken to install each pipestand, so each support carries a proportional and equal amount of weight.
10. **Spacing:** Manufacturer's recommended spacing is not to exceed 10-foot centers depending upon the load. Make certain each pipestand is properly elevated and loading is distributed evenly to all pipestands. Support spacing is not to exceed the maximum spacing required in the pipe specifications, where applicable.
11. **Availability:** Base Strut Pipestands are marketed throughout the United States through representatives and distributors.
12. **Maintenance:** Normal maintenance is not required. Semi-annual inspection is required to check pipestand position and set pipe alignment, check proper weight distribution, and to correct improper installation that may cause pipestand damage or failures.
13. **Technical Services:** Please call MIRO INDUSTRIES, INC: (800) 768-6978 or visit our website [www.miroind.com](http://www.miroind.com) for technical information and for graphic and CAD drawing downloads.



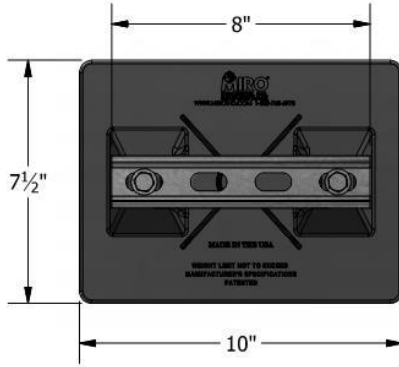

**TOP VIEW**

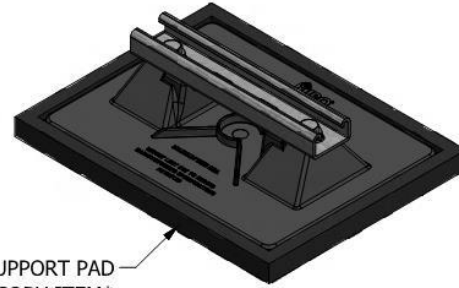

**ISOMETRIC VIEW**

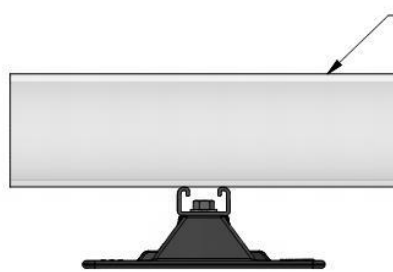

**SIDE VIEW**

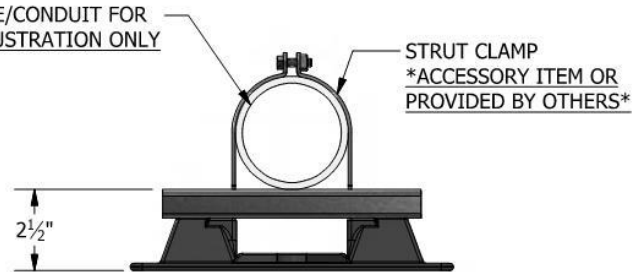

**END VIEW**

**ACCESSORIES**

- Strut Clamp - Order to Pipe O.D.
- 7½" x 10" Support pad
- Eternabond® 2-sided tape

**PRODUCT DESCRIPTION**

A pipe support with "strut" used to support roof-mounted electrical conduit, solar piping, gas pipes and other mechanical piping. Pipes rest on a 8" length of strut which is mounted on the base. The pipes can be fastened by using the appropriate pipe clamp.

**KEY INFORMATION**

- Designed to support conduit (ganged) cable trays or other mechanical piping.
- Fixed height of 2½", even load required, maximum load is 172 lbs. (Max load based on 3.0 psi to the roof deck)
- Unit weight: 1.78 lbs.
- 12 per case, 21 lbs. per case, (DW= 11 lbs.)
- Recommended spacing is not to exceed 10' centers depending upon the load. Make certain each support is properly elevated to evenly distribute weight at all support locations.
- Base Material: Polycarbonate
- All metal parts are either stainless steel or hot-dip galvanized.

The information contained in this drawing is the sole property of MIRO Industries, Inc. Any reproduction in part or as a whole without written permission of MIRO Industries, Inc. is prohibited.	DATE:	8-BASE STRUT-2
	JAN 2019	



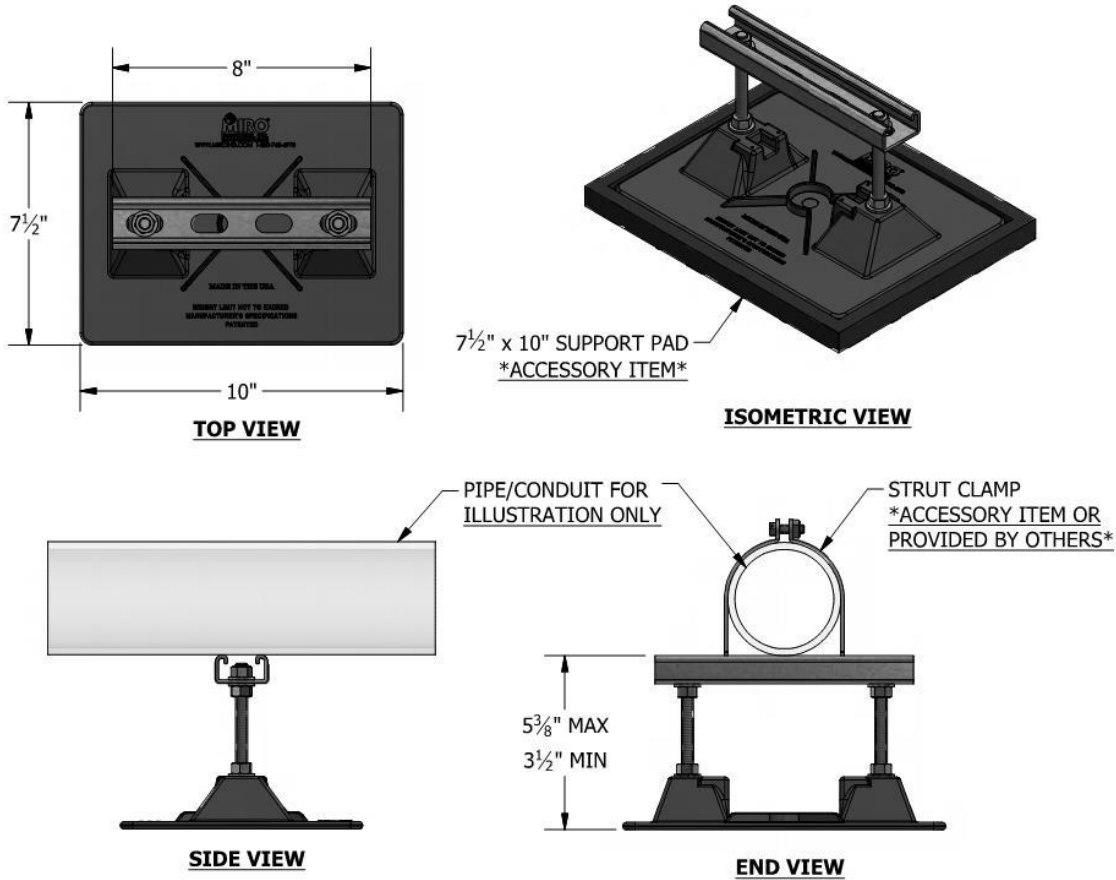

**ACCESSORIES**

- Strut Clamp - Order to Pipe O.D.
- 7½" x 10" Support pad
- Eternabond® 2-sided tape

**PRODUCT DESCRIPTION**

A pipe support with "strut" used to support roof-mounted electrical conduit, solar piping, gas pipes and other mechanical piping. Pipes rest on a 8" length of strut which is mounted on the base. The pipes can be fastened by using the appropriate pipe clamp.

**KEY INFORMATION**

- Designed to support conduit (ganged) cable trays or other mechanical piping.
- Adjustable from the factory set maximum height of 5-3/8" down to a minimum height of 3-1/2"
- Maximum load is 172 lbs. (3.0 psi) Make certain each support is properly elevated to evenly distribute weight at all support locations.
- Unit Weight: 2.10 lbs.
- 12 per case, 23 lbs. per case, (DW= 19 lbs.)
- Recommended spacing is not to exceed 10' centers depending upon the load.
- Base Material: Polycarbonate
- All metal parts are either stainless steel or hot-dip galvanized.

The information contained in this drawing is the sole property of MIRO Industries, Inc. Any reproduction in part or as a whole without written permission of MIRO Industries, Inc. is prohibited.	DATE:	8-BASE STRUT-5
	JAN 2019	

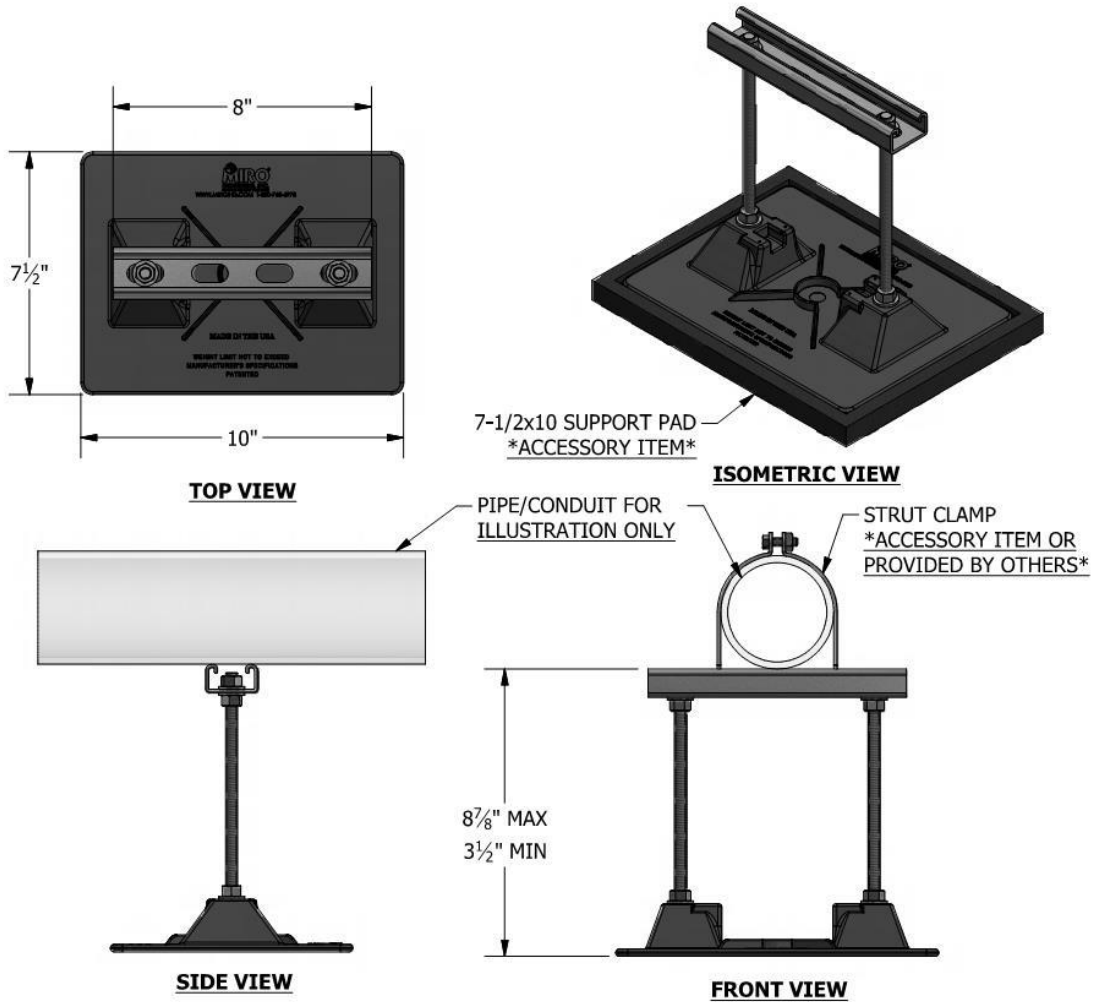

**ACCESSORIES**

- Strut Clamp - Order to Pipe O.D.
- 7½" x 10" Support pad
- Eternabond® 2-sided tape

**PRODUCT DESCRIPTION**

A pipe support with "strut" used to support roof-mounted electrical conduit, solar piping, gas pipes and other mechanical piping. Pipes rest on a 8" length of strut which is mounted on the base. The pipes can be fastened by using the appropriate pipe clamp.

**KEY INFORMATION**

- Designed to support conduit (ganged) cable trays or other mechanical piping.
- Adjustable from the factory set maximum height of 8-7/8" down to a minimum height of 3-1/2"
- Maximum load is 172 lbs. (3.0 psi) Make certain each support is properly elevated to evenly distribute weight at all support locations.
- Unit Weight: 2.33 lbs.
- 12 per case, 26 lbs. per case, (DW= 29 lbs.)
- Recommended spacing is not to exceed 10' centers depending upon the load.
- Base Material: Polycarbonate
- All metal parts are either stainless steel or hot-dip galvanized.

The information contained in this drawing is the sole property of MIRO Industries, Inc. Any reproduction in part or as a whole without written permission of MIRO Industries, Inc. is prohibited.	DATE:	8-BASE STRUT-8
	JAN 2019	

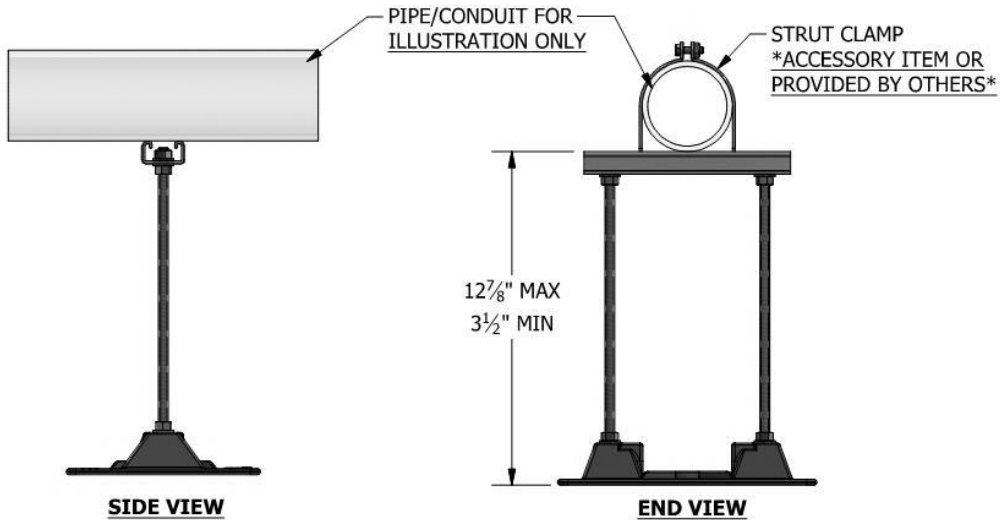
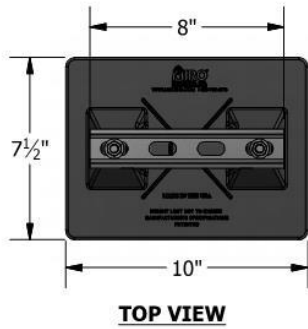

**ACCESSORIES**

- Strut Clamp - Order to Pipe O.D.
- 7½" x 10" Support pad
- Eternabond® 2-sided tape

**PRODUCT DESCRIPTION**

A pipe support with "strut" used to support roof-mounted electrical conduit, solar piping, gas pipes and other mechanical piping. Pipes rest on a 8" length of strut which is mounted on the base. The pipes can be fastened by using the appropriate pipe clamp.

**KEY INFORMATION**

- Designed to support conduit (ganged) cable trays or other mechanical piping.
- Adjustable from the factory set maximum height of 12-7/8" down to a minimum height of 3-1/2"
- Maximum load is 172 lbs. (3.0 psi) Make certain each support is properly elevated to evenly distribute weight at all support locations.
- Unit Weight: 2.57 lbs.
- 7 per case, 17 lbs. per case, (DW= 20 lbs.)
- Recommended spacing is not to exceed 10' centers depending upon the load.
- Base Material: Polycarbonate
- All metal parts are either stainless steel or hot-dip galvanized.

The information contained in this drawing is the sole property of MIRO Industries, Inc. Any reproduction in part or as a whole without written permission of MIRO Industries, Inc. is prohibited.	DATE:	8-BASE STRUT-12
	JAN 2019	

**Strut Size:**  
8" Strut  
1-5/8" x 13/16"

## Product Data Sheet

# 8-Base Strut-8 SS and 8-Base Strut-12 SS

1. **Product Name:** 8-Base Strut-8 SS and 8-Base Strut-12 SS.
2. **Manufacturer:** MIRO INDUSTRIES, INC.  
844 South 430 West, Suite 100,  
Heber City, Utah 84032  
Phone: (800) 768-6978  
Fax: (800) 440-7958
3. **Product Description:** A rooftop support with "strut" used to support roof-mounted electrical conduit, solar piping, gas pipes, or other mechanical piping. Pipes rest on a length of hot-dip galvanized steel strut. The pipe support base is made of stainless-steel, and all other metal parts are made of hot-dip galvanized or stainless-steel.
4. **Product Performance:** The base is gently rounded to allow movement upon the roof to prevent gouging the roof membrane. Each support offers the following clearances above the roof:
  - 8-Base Strut-8 SS has a factory-set maximum height of 8-7/8 inches with adjustability down to 3-1/8 inches.
  - 8-Base Strut-12 SS has a factory-set maximum height of 12-7/8 inches with adjustability down to 3-1/8 inches.More than one conduit or pipe may be ganged on the pipe support and attached with typical pipe clamps or clips, so long as the total load weight per support does not exceed recommended weight limit.
5. **Compatibility:** Base Strut Pipestands are recommended and are compatible to use with all current deck types and with all commonly used built-up and single-ply roofing membranes where roof-mounted pipes occur.
6. **Load Weight:** Maximum load weight may not exceed 524 pounds on each of the 8-Base Strut series pipestands with the stainless-steel base.
7. **Composition and Materials:** The pipestand consists of three major components: (1) A stainless-steel deck base, (2) 3/8 inch diameter stainless-steel all thread with hot-dip galvanized hardware, and (3) an 8 inch piece of 1-5/8 x 13/16 inch hot-dip galvanized strut. Carbon black is added to the polycarbonate resin for UV-resistance and protection.
8. **Size:** The 8-Base-8 SS and 8-Base Strut-12 SS pipestands have a 12 x 16 inch stainless-steel deck base and an 8 inch piece of 1-5/8 x 13/16 inch hot-dip galvanized strut. The 8-Base Strut models provide height adjustability as outlined above.
9. **Installation:** (1) Center the pipestand beneath the pipe so that the strut allows the pipe to be positioned squarely over the pipestand. (2) Adjust the pipestand to the desired height and ensure load is evenly distributed with other pipestands. Make certain the strut is level. (3) Set the pipe on the pipestand without dropping or causing any undue impact.

An additional sheet of roofing material, a traffic pad, or a MIRO Support Pad should be installed beneath the pipestand. For built up roofs, clear all loose aggregate from an area 2 inches outside each base footprint and then follow the installation directions outlined above. Care should be taken to install each pipestand, so each support carries a proportional and equal amount of weight.
10. **Spacing:** Manufacturer's recommended spacing is not to exceed 10-foot centers depending upon the load. Make certain each pipestand is properly elevated and loading is distributed evenly to all pipestands. Support spacing is not to exceed the maximum spacing required in the pipe specifications, where applicable.
11. **Availability:** Base Strut Pipestands are marketed throughout the United States through representatives and distributors.
12. **Maintenance:** Normal maintenance is not required. Semi-annual inspection is required to check pipestand position and set pipe alignment, check proper weight distribution, and to correct improper installation that may cause pipestand damage or failures.
13. **Technical Services:** Please call MIRO INDUSTRIES, INC.: (800) 768-6978 or visit our website [www.miroind.com](http://www.miroind.com) for technical information and for graphic and CAD drawing downloads.



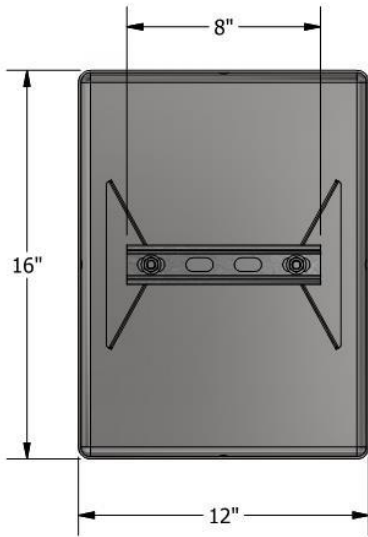

**TOP VIEW**

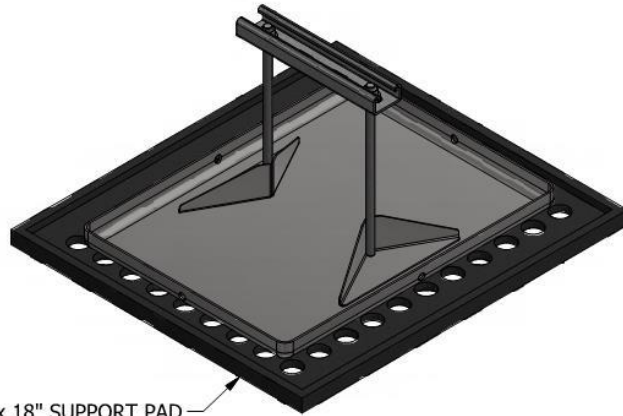

**ISOMETRIC VIEW**

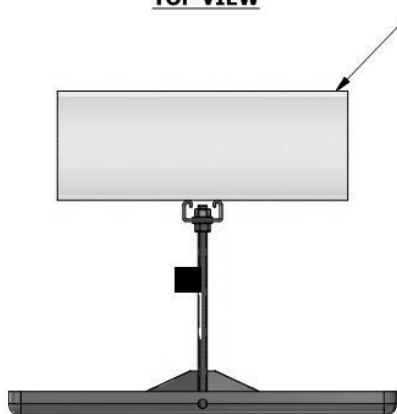

**SIDE VIEW**

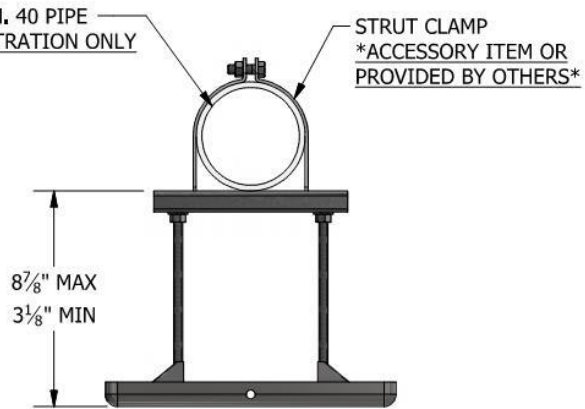

**END VIEW**

**ACCESSORIES**

- Strut Clamp - Order to Pipe O.D.
- 16" x 18" Support pad
- Eternabond® 2-sided tape

**PRODUCT DESCRIPTION**

A pipe support with "strut" used to support roof-mounted electrical conduit, solar piping, gas pipes and other mechanical piping. Pipes rest on a 8" length of strut which is mounted on the base. The pipes can be fastened by using the appropriate pipe clamp.

**KEY INFORMATION**

- Designed to support conduit (ganged) cable trays or other mechanical piping.
- Adjustable from the factory set maximum height of 8-7/8" down to a minimum height of 3-1/8"
- Maximum load is 419 lbs. (3.0 psi) Make certain each support is properly elevated to evenly distribute weight at all support locations.
- Unit Weight: 8.69 lbs.
- Recommended spacing is not to exceed 10' centers depending upon the load.
- Base Material: Stainless steel
- All metal parts are either stainless steel or hot-dip galvanized.

The information contained in this drawing is the sole property of MIRO Industries, Inc. Any reproduction in part or as a whole without written permission of MIRO Industries, Inc. is prohibited.

DATE:  
JAN 2019

8-BASE STRUT-8 SS



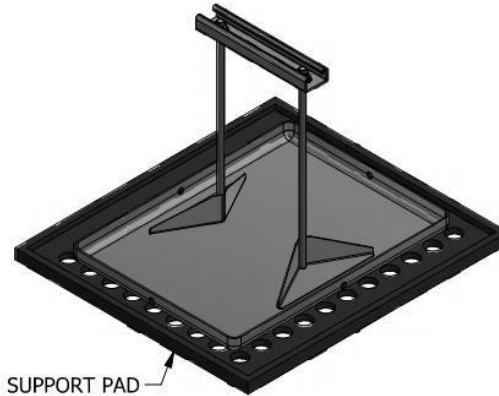
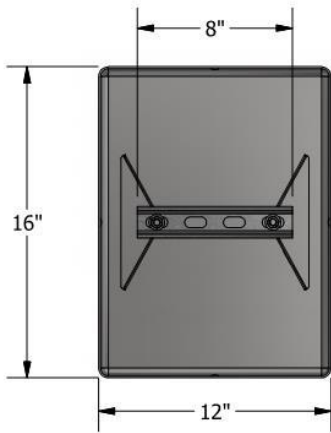

16" x 18" SUPPORT PAD  
\*ACCESSORY ITEM\*

**ISOMETRIC VIEW**

**TOP VIEW**



**SIDE VIEW**

4" SCH. 40 PIPE  
ILLUSTRATION ONLY

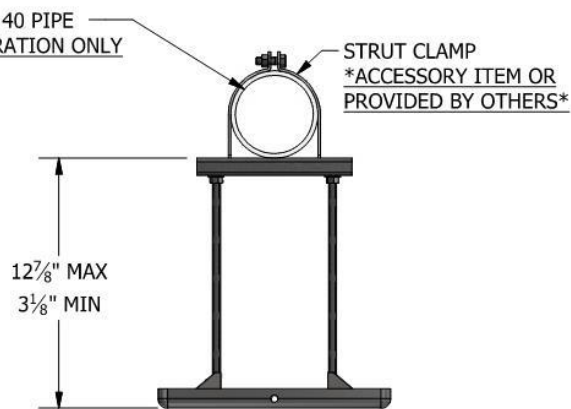

**END VIEW**

STRUT CLAMP  
\*ACCESSORY ITEM OR  
PROVIDED BY OTHERS\*

12<sup>7</sup>/<sub>8</sub>" MAX  
3<sup>1</sup>/<sub>8</sub>" MIN

**ACCESSORIES**

- Strut Clamp - Order to Pipe O.D.
- 16" x 18" Support pad
- Eternabond® 2-sided tape

**PRODUCT DESCRIPTION**

A pipe support with "strut" used to support roof-mounted electrical conduit, solar piping, gas pipes and other mechanical piping. Pipes rest on a 12" length of strut which is mounted on the base. The pipes can be fastened by using the appropriate pipe clamp.

**KEY INFORMATION**

- Designed to support conduit (ganged) cable trays or other mechanical piping.
- Adjustable from the factory set maximum height of 12-7/8" down to a minimum height of 3-1/8"
- Maximum load is 186 lbs. (All-thread capacity) Make certain each support is properly elevated to evenly distribute weight at all support locations.
- Unit Weight: 8.93 lbs.
- Recommended spacing is not to exceed 10' centers depending upon the load.
- Base Material: Stainless steel
- All metal parts are either stainless steel or hot-dip galvanized.

The information contained in this drawing is the sole property of MIRO Industries, Inc. Any reproduction in part or as a whole without written permission of MIRO Industries, Inc. is prohibited.

DATE:  
JAN 2019

8-BASE STRUT-12 SS

<p><b>Strut Size:</b> 12" Strut 1-5/8" x 13/16"</p>
---

## Product Data Sheet

# 12-Base Strut-8 and 12-Base Strut-12

1. **Product Name:** 12-Base Strut-8 and 12-Base Strut-12
2. **Manufacturer:** MIRO INDUSTRIES, INC.  
844 South 430 West, Suite 100,  
Heber City, Utah 84032  
Phone: (800) 768-6978  
Fax: (800) 440-7958
3. **Product Description:** A rooftop support with "strut" used to support roof-mounted electrical conduit, solar piping, gas pipes, or other mechanical piping. Pipes rest on a length of hot-dip galvanized steel strut. The pipe support base is made of polycarbonate resin, and all other metal parts are made of hot-dip galvanized or stainless-steel.
4. **Product Performance:** The base is gently rounded to allow movement upon the roof to prevent gouging the roof membrane. Each support offers the following clearances above the roof:
  - o 12-Base Strut-8 has a factory-set maximum height of 9-1/4 inches with adjustability down to 4-1/4 inches.
  - o 12-Base Strut-12 has a factory-set maximum height of 13-1/4 inches with adjustability down to 4-1/4 inches.More than one conduit or pipe may be ganged on the pipe support and attached with typical pipe clamps or clips, so long as the total load weight per support does not exceed recommended weight limit.
5. **Compatibility:** Base Strut Pipestands are recommended and are compatible to use with all current deck types and with all commonly used built-up and single-ply roofing membranes where roof-mounted pipes occur.
6. **Load Weight:** Maximum load weight may not exceed 335 pounds on each of the 12-Base Strut series pipestands with the polycarbonate base.
7. **Composition and Materials:** The pipestand consists of three major components: (1) A polycarbonate resin deck base, (2) 1/2 inch diameter stainless-steel all thread with hot-dip galvanized hardware, and (3) a 12 inch piece of 1-5/8 x 13/16 inch hot-dip galvanized strut. Carbon black is added to the polycarbonate resin for UV-resistance and protection.
8. **Size:** The 12-Base Strut-8 and 12-Base Strut-12 pipestands have a 9 x 15-1/4 inch polycarbonate deck base and a 12 inch piece of 1-5/8 x 13/16 inch hot-dip galvanized 12-Bd strut. The 12-Base Strut models provide height adjustability as outlined above.
9. **Installation:** (1) Center the pipestand beneath the pipe so that the strut allows the pipe to be positioned squarely over the pipestand. (2) Adjust the pipestand to the desired height and ensure load is evenly distributed with other pipestands. Make certain the strut is level. (3) Set the pipe on the pipestand without dropping or causing any undue impact.

An additional sheet of roofing material, a traffic pad, or a MIRO Support Pad should be installed beneath the pipestand. For built up roofs, clear all loose aggregate from an area 2 inches outside each base footprint and then follow the installation directions outlined above. Care should be taken to install each pipestand, so each support carries a proportional and equal amount of weight.
10. **Spacing:** Manufacturer's recommended spacing is not to exceed 10-foot centers, depending upon the load. Make certain each pipestand is properly elevated and loading is distributed evenly to all pipestands. Support spacing is not to exceed the maximum spacing required in the pipe specifications, where applicable.
11. **Availability:** Base Strut Pipestands are marketed throughout the United States through representatives and distributors.
12. **Maintenance:** Normal maintenance is not required. Semi-annual inspection is required to check pipestand position and set pipe alignment, check proper weight distribution, and to correct improper installation that may cause pipestand damage or failures.
13. **Technical Services:** Please call MIRO INDUSTRIES, INC: (800) 768-6978 or visit our website [www.miroind.com](http://www.miroind.com) for technical information and for graphic and CAD drawing downloads.

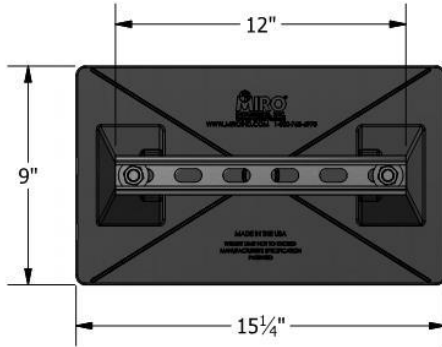

**TOP VIEW**



**ISOMETRIC VIEW**

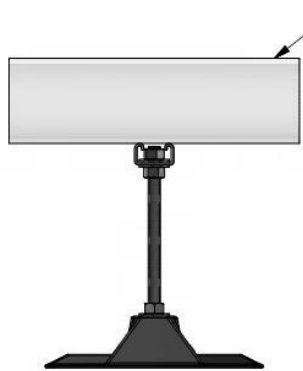

**SIDE VIEW**

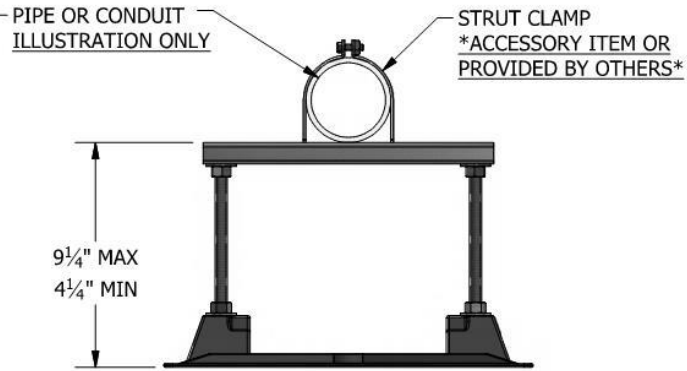

**END VIEW**

**ACCESSORIES**

- Strut Clamp - Order to Pipe O.D.
- 9" x 15 1/4" Support pad
- Eternabond® 2-sided tape

**PRODUCT DESCRIPTION**

A pipe support with "strut" used to support roof-mounted electrical conduit, solar piping, gas pipes and other mechanical piping. Pipes rest on a 12" length of strut which is mounted on the base. The pipes can be fastened by using the appropriate pipe clamp.

**KEY INFORMATION**

- Designed to support conduit (ganged) cable trays or other mechanical piping.
- Adjustable from the factory set maximum height of 9-1/4" down to a minimum height of 4-1/4"
- Maximum load is 335 lbs. (3.0 psi) Make certain each support is properly elevated to evenly distribute weight at all support locations.
- Unit Weight: 3.88 lbs.
- 8 per case, 30 lbs. per case, (DW= 36 lbs.)
- Recommended spacing is not to exceed 10' centers depending upon the load.
- Base Material: Polycarbonate
- All metal parts are either stainless steel or hot-dip galvanized.

The information contained in this drawing is the sole property of MIRO Industries, Inc. Any reproduction in part or as a whole without written permission of MIRO Industries, Inc. is prohibited.	DATE:	<b>12-BASE STRUT-8</b>
	JAN 2019	

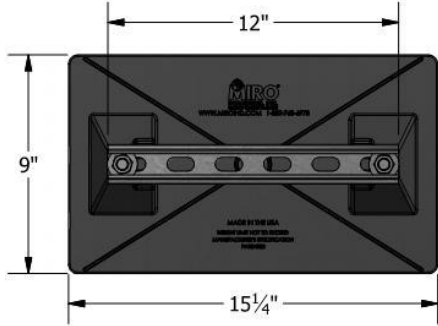

**TOP VIEW**



9" x 15 1/4" SUPPORT PAD  
\*ACCESSORY ITEM\*

**ISOMETRIC VIEW**



**SIDE VIEW**

PIPE OR CONDUIT  
ILLUSTRATION ONLY

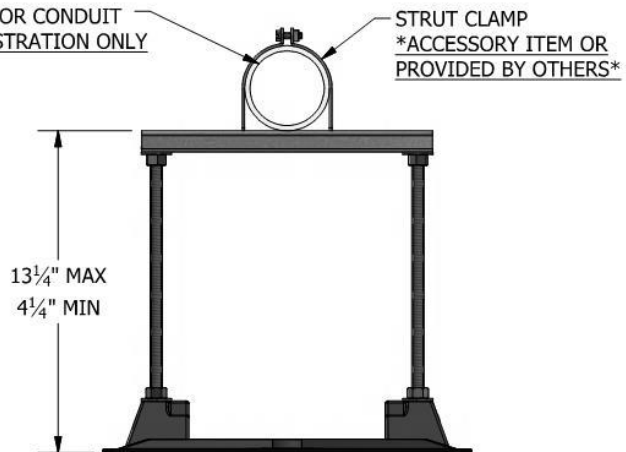

**END VIEW**

STRUT CLAMP  
\*ACCESSORY ITEM OR  
PROVIDED BY OTHERS\*

**ACCESSORIES**

- Strut Clamp - Order to Pipe O.D.
- 9" x 15 1/4" Support pad
- Eternabond® 2-sided tape

**PRODUCT DESCRIPTION**

A pipe support with "strut" used to support roof-mounted electrical conduit, solar piping, gas pipes and other mechanical piping. Pipes rest on a 12" length of strut which is mounted on the base. The pipes can be fastened by using the appropriate pipe clamp.

**KEY INFORMATION**

- Designed to support conduit (ganged) cable trays or other mechanical piping.
- Adjustable from the factory set maximum height of 13-1/4" down to a minimum height of 4-1/4"
- Maximum load is 335 lbs. (3.0 psi) Make certain each support is properly elevated to evenly distribute weight at all support locations.
- Unit Weight: 4.34 lbs.
- 6 per case, 25 lbs. per case, (DW= 36 lbs.)
- Recommended spacing is not to exceed 10' centers depending upon the load.
- Base Material: Polycarbonate
- All metal parts are either stainless steel or hot-dip galvanized.

The information contained in this drawing is the sole property of MIRO Industries, Inc. Any reproduction in part or as a whole without written permission of MIRO Industries, Inc. is prohibited.	DATE:	12-BASE STRUT-12
	JAN 2019	

**Strut Size:**  
12" Strut  
1-5/8" x 13/16"

## Product Data Sheet

# 12-Base Strut-8 SS and 12-Base Strut-12 SS

1. **Product Name:** 12-Base Strut-8 SS and 12-Base Strut-12 SS.
2. **Manufacturer:** MIRO INDUSTRIES, INC.  
844 South 430 West, Suite 100,  
Heber City, Utah 84032  
Phone: (800) 768-6978  
Fax: (800) 440-7958
3. **Product Description:** A rooftop support with "strut" used to support roof-mounted electrical conduit, solar piping, gas pipes, or other mechanical piping. Pipes rest on a length of hot-dip galvanized steel strut. The pipe support base is made of stainless-steel, and all other metal parts are made of hot-dip galvanized or stainless-steel.
4. **Product Performance:** The base is gently rounded to allow movement upon the roof to prevent gouging the roof membrane. Each support offers the following clearances above the roof:
  - o 12-Base Strut-8 SS has a factory-set maximum height of 9-1/4 inches with adjustability down to 3-1/4 inches.
  - o 12-Base Strut-12 SS has a factory-set maximum height of 13-1/4 inches with adjustability down to 3-1/4 inches.More than one conduit or pipe may be ganged on the pipe support and attached with typical pipe clamps or clips, so long as the total load weight per support does not exceed recommended weight limit.
5. **Compatibility:** Base Strut Pipestands are recommended and are compatible to use with all current deck types and with all commonly used built-up and single-ply roofing membranes where roof-mounted pipes occur.
6. **Load Weight:** Maximum load weight may not exceed 524 pounds on each of the 12-Base Strut series pipestands with the stainless-steel base.
7. **Composition and Materials:** The pipestand consists of three major components: (1) A stainless-steel deck base, (2) 1/2 inch diameter stainless-steel all thread with hot-dip galvanized hardware, and (3) a 12 inch piece of 1-5/8 x 13/16 inch hot-dip galvanized strut. Carbon black is added to the polycarbonate resin for UV-resistance and protection.
8. **Size:** The 12-Base Strut-8 SS and 12-Base Strut-12 SS series pipestands have a 12 x 16 inch stainless-steel deck base and a 12 inch piece of 1-5/8 x 13/16 inch hot-dip galvanized strut. The 12-Base Strut models provide height adjustability as outlined above.
9. **Installation:** (1) Center the pipestand beneath the pipe so that the strut allows the pipe to be positioned squarely over the pipestand. (2) Adjust the pipestand to the desired height and ensure load is evenly distributed with other pipestands. Make certain the strut is level. (3) Set the pipe on the pipestand without dropping or causing any undue impact.  
  
An additional sheet of roofing material, a traffic pad, or a MIRO Support Pad should be installed beneath the pipestand. For built up roofs, clear all loose aggregate from an area 2 inches outside each base footprint and then follow the installation directions outlined above. Care should be taken to install each pipestand, so each support carries a proportional and equal amount of weight.
10. **Spacing:** Manufacturer's recommended spacing is not to exceed 10-foot centers, depending upon the load. Make certain each pipestand is properly elevated and loading is distributed evenly to all pipestands. Support spacing is not to exceed the maximum spacing required in the pipe specifications, where applicable.
11. **Availability:** Base Strut Pipestands are marketed throughout the United States through representatives and distributors.
12. **Maintenance:** Normal maintenance is not required. Semi-annual inspection is required to check pipestand position and set pipe alignment, check proper weight distribution, and to correct improper installation that may cause pipestand damage or failures.
13. **Technical Services:** Please call MIRO INDUSTRIES, INC: (800) 768-6978 or visit our website [www.miroind.com](http://www.miroind.com) for technical information and for graphic and CAD drawing downloads.



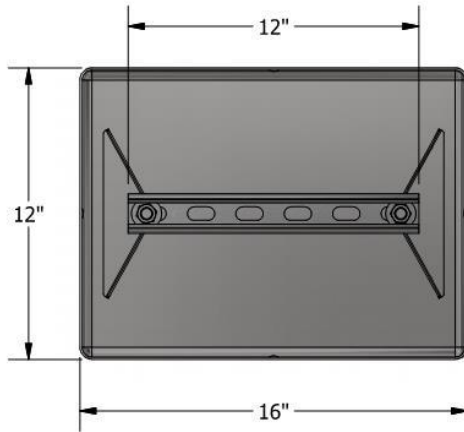

**TOP VIEW**

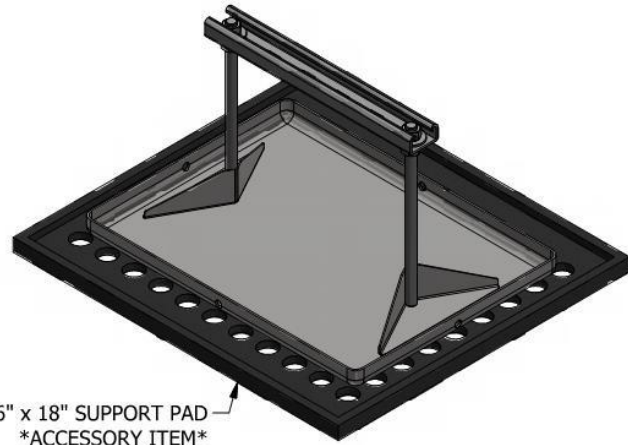

16" x 18" SUPPORT PAD  
\*ACCESSORY ITEM\*

**ISOMETRIC VIEW**



**SIDE VIEW**

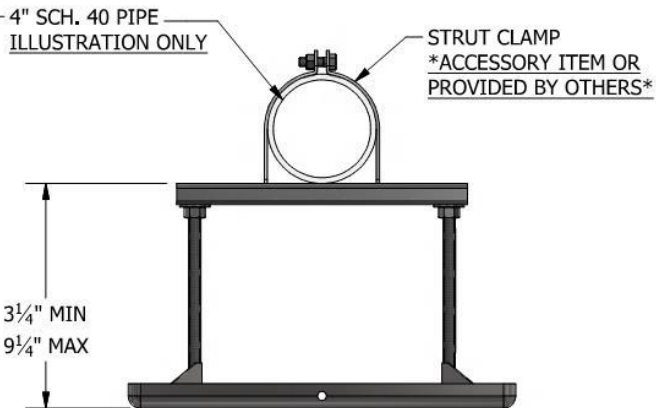

**END VIEW**

**ACCESSORIES**

- Strut Clamp - Order to Pipe O.D.
- 16" x 18" Support pad
- Eternabond® 2-sided tape

**PRODUCT DESCRIPTION**

A pipe support with "strut" used to support roof-mounted electrical conduit, solar piping, gas pipes and other mechanical piping. Pipes rest on a 12" length of strut which is mounted on the base. The pipes can be fastened by using the appropriate pipe clamp.

**KEY INFORMATION**

- Designed to support conduit (ganged) cable trays or other mechanical piping
- Adjustable from the factory set maximum height of 9-1/4" down to a minimum height of 3-1/4"
- Maximum load is 524 lbs. (3,0 psi) Make certain each support is properly elevated to evenly distribute weight at all support locations
- Unit Weight: 9.76 lbs.
- Recommended spacing is not to exceed 10' centers depending upon the load
- Base Material: Stainless steel
- All metal parts are either stainless steel or hot-dip galvanized

The information contained in this drawing is the sole property of MIRO Industries, Inc. Any reproduction in part or as a whole without written permission of MIRO Industries, Inc. is prohibited.	DATE:	<b>12-BASE STRUT-8 SS</b>
	JAN 2019	

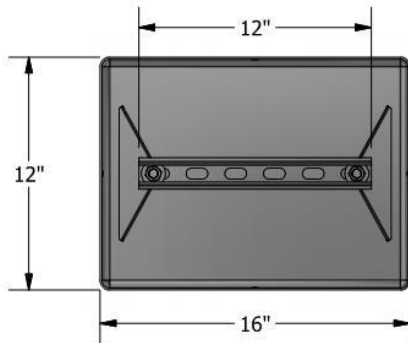

**TOP VIEW**

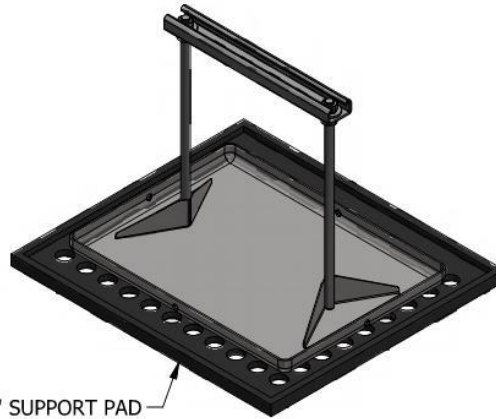

16" x 18" SUPPORT PAD  
\*ACCESSORY ITEM\*

**ISOMETRIC VIEW**



**FRONT VIEW**

4" SCH. 40 PIPE  
ILLUSTRATION ONLY

STRUT CLAMP  
\*ACCESSORY ITEM OR  
PROVIDED BY OTHERS\*

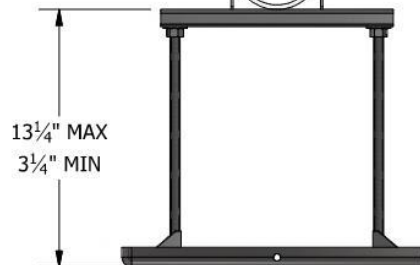

13 1/4" MAX  
3 1/4" MIN

**SIDE VIEW**

**ACCESSORIES**

- Strut Clamp - Order to Pipe O.D.
- 16" x 18" Support pad
- Eternabond® 2-sided tape

**PRODUCT DESCRIPTION**

A pipe support with "strut" used to support roof-mounted electrical conduit, solar piping, gas pipes and other mechanical piping. Pipes rest on a 12" length of strut which is mounted on the base. The pipes can be fastened by using the appropriate pipe clamp.

**KEY INFORMATION**

- Designed to support conduit (ganged) cable trays or other mechanical piping
- Adjustable from the factory set maximum height of 13-1/4" down to a minimum height of 3-1/4"
- Maximum load is 524 lbs. (3.0 psi) Make certain each support is properly elevated to evenly distribute weight at all support locations
- Unit Weight: 10.21 lbs.
- Recommended spacing is not to exceed 10' centers depending upon the load
- Base Material: Stainless steel
- All metal parts are either stainless steel or hot-dip galvanized

The information contained in this drawing is the sole property of MIRO Industries, Inc. Any reproduction in part or as a whole without written permission of MIRO Industries, Inc. is prohibited.

DATE:  
JAN 2019

12-BASE STRUT-12 SS

<p><b>Strut Size:</b> 16" Strut 1-5/8" x 13/16"</p>
---

## Product Data Sheet

# 16-Base Strut-8 and 16-Base Strut-12

- Product Name:** 16-Base Strut-8 and 16-Base Strut-12.
- Manufacturer:** MIRO INDUSTRIES, INC.  
844 South 430 West, Suite 100,  
Heber City, Utah 84032  
Phone: (800) 768-6978  
Fax: (800) 440-7958
- Product Description:** A rooftop support with "strut" used to support roof-mounted electrical conduit, solar piping, gas pipes, or other mechanical piping. Pipes rest on a length of hot-dip galvanized steel strut. The pipe support base is made of polycarbonate resin and all other metal parts are made of hot-dip galvanized or stainless-steel.
- Product Performance:** The base is gently rounded to allow movement upon the roof to prevent gouging the roof membrane. Each support offers the following clearances above the roof:
  - 16-Base Strut-8 has a factory-set maximum height of 9-1/4 inches with adjustability down to 4-3/4 inches.
  - 16-Base Strut-12 has a factory-set maximum height of 13-1/4 inches with adjustability down to 4-3/4 inches.More than one conduit or pipe may be ganged on the pipe support and attached with typical pipe clamps or clips, so long as the total load weight per support does not exceed recommended weight limit.
- Compatibility:** Base Strut Pipestands are recommended and are compatible to use with all current deck types and with all commonly used built-up and single-ply roofing membranes where roof-mounted pipes occur.
- Load Weight:** Maximum load weight may not exceed 578 pounds on each of the 16-Base Strut series pipestands.
- Composition and Materials:** The pipestand consists of three major components: (1) A polycarbonate resin deck base, (2) 1/2 inch diameter stainless-steel all thread with hot-dip galvanized hardware, and (3) a 16 inch piece of 1-5/8 x 13/16 inch hot-dip galvanized strut. Carbon black is added to the polycarbonate resin for UV-resistance and protection.
- Size:** The 16-Base Strut series pipestands have a 16 x 18 inch polycarbonate deck base and a 16 inch piece of 1-5/8 x 13/16 inch hot-dip galvanized strut. The 16-Base Strut models provide height adjustability as outlined above.
- Installation:** (1) Center the pipestand beneath the pipe so that the strut allows the pipe to be positioned squarely over the pipestand. (2) Adjust the pipestand to the desired height and ensure load is evenly distributed with other pipestands. Make certain the strut is level. (3) Set the pipe on the pipestand without dropping or causing any undue impact.

An additional sheet of roofing material, a traffic pad, or a MIRO Support Pad should be installed beneath the pipestand. For built up roofs, clear all loose aggregate from an area 2 inches outside each base footprint and then follow the installation directions outlined above. Care should be taken to install each pipestand, so each support carries a proportional and equal amount of weight.
- Spacing:** Manufacturer's recommended spacing is not to exceed 10-foot centers depending upon the load. Make certain each pipestand is properly elevated and loading is distributed evenly to all pipestands. Support spacing is not to exceed the maximum spacing required in the pipe specifications, where applicable.
- Availability:** Base Strut Pipestands are marketed throughout the United States through representatives and distributors.
- Maintenance:** Normal maintenance is not required. Semi-annual inspection is required to check pipestand position and set pipe alignment, check proper weight distribution, and to correct improper installation that may cause pipestand damage or failures.
- Technical Services:** Please call MIRO INDUSTRIES, INC: (800) 768-6978 or visit our website [www.miroind.com](http://www.miroind.com) for technical information and for graphic and CAD drawing downloads.

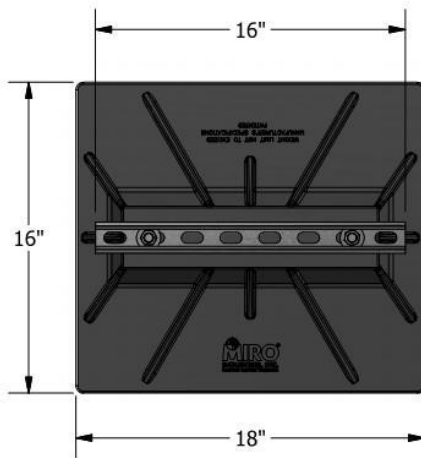

**TOP VIEW**

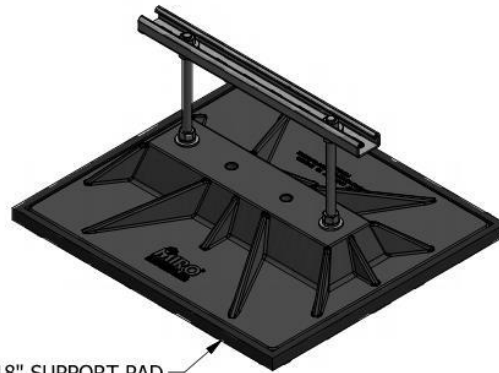

16" x 18" SUPPORT PAD  
\*ACCESSORY ITEM\*

**ISOMETRIC VIEW**

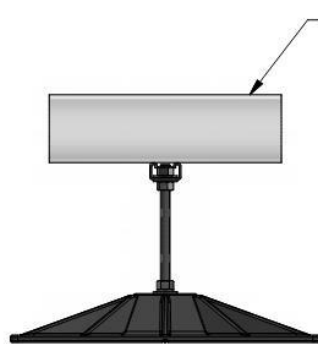

**SIDE VIEW**

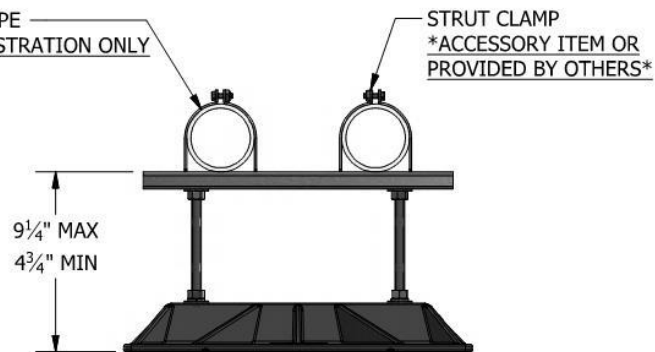

**END VIEW**

**ACCESSORIES**

- Strut Clamp - Order to Pipe O.D.
- 16" x 18" Support pad
- Eternabond® 2-sided tape

**PRODUCT DESCRIPTION**

A pipe support with "strut" used to support roof-mounted electrical conduit, solar piping, gas pipes and other mechanical piping. Pipes rest on a 16" length of strut which is mounted on the base. The pipes can be fastened by using the appropriate pipe clamp.

**KEY INFORMATION**

- Designed to support conduit (ganged) cable trays or other mechanical piping.
- Adjustable from the factory set maximum height of 9-1/4" down to a minimum height of 4-3/4"
- Maximum load is 578 lbs. (3.0 psi) Make certain each support is properly elevated to evenly distribute weight at all support locations.
- Unit Weight: 7.44 lbs.
- 4 per case, 33 lbs. per case, (DW= 42 lbs.)
- Recommended spacing is not to exceed 10' centers depending upon the load.
- Base Material: Polycarbonate
- All metal parts are either stainless steel or hot-dip galvanized.

The information contained in this drawing is the sole property of MIRO Industries, Inc. Any reproduction in part or as a whole without written permission of MIRO Industries, Inc. is prohibited.	DATE:	16-BASE STRUT-8
	JAN 2019	



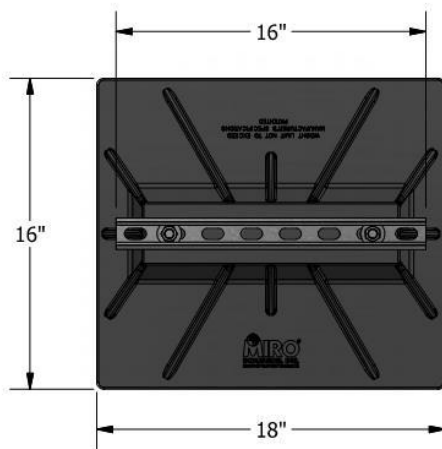

**TOP VIEW**

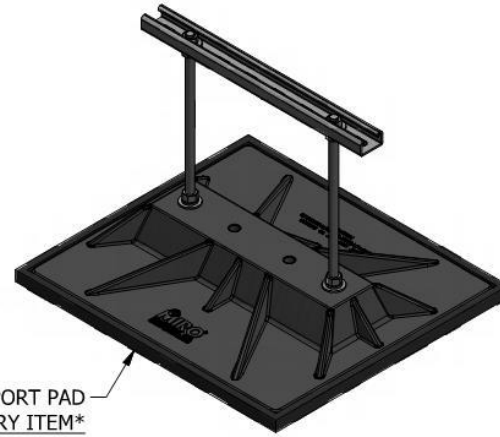

**ISOMETRIC VIEW**



**SIDE VIEW**

16" x 18" SUPPORT PAD  
\*ACCESSORY ITEM\*

3" PIPE  
ILLUSTRATION ONLY

STRUT CLAMP  
\*ACCESSORY ITEM OR  
PROVIDED BY OTHERS\*

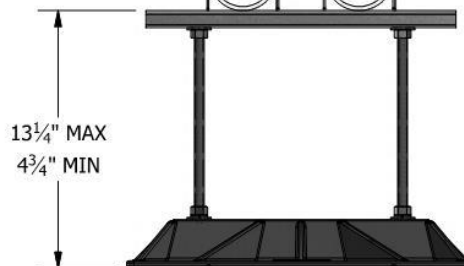

**END VIEW**

13 1/4" MAX  
4 3/4" MIN

**ACCESSORIES**

- Strut Clamp - Order to Pipe O.D.
- 16" x 18" Support pad
- Eternabond® 2-sided tape

**PRODUCT DESCRIPTION**

A pipe support with "strut" used to support roof-mounted electrical conduit, solar piping, gas pipes and other mechanical piping. Pipes rest on a 16" length of strut which is mounted on the base. The pipes can be fastened by using the appropriate pipe clamp.

**KEY INFORMATION**

- Designed to support conduit (ganged) cable trays or other mechanical piping.
- Adjustable from the factory set maximum height of 13-1/4" down to a minimum height of 4-3/4"
- Maximum load is 578 lbs. (3.0 psi) Make certain each support is properly elevated to evenly distribute weight at all support locations.
- Unit Weight: 7.90 lbs.
- 4 per case, 36 lbs. per case, (DW= 71 lbs.)
- Recommended spacing is not to exceed 10' centers depending upon the load.
- Base Material: Polycarbonate
- All metal parts are either stainless steel or hot-dip galvanized.

The information contained in this drawing is the sole property of MIRO Industries, Inc. Any reproduction in part or as a whole without written permission of MIRO Industries, Inc. is prohibited.

DATE:  
JAN 2019

16-BASE STRUT-12



**Strut Size:**  
20" Strut  
1-5/8" x 1-5/8"

## Product Data Sheet

# 20-Base Strut-4, 20-Base Strut-8, and 20-Base Strut-18

1. **Product Name:** 20-Base Strut-4, 20-Base Strut-8 and 20-Base Strut-18.
2. **Manufacturer:** MIRO INDUSTRIES, INC.  
844 South 430 West, Suite 100,  
Heber City, Utah 84032  
Phone: (800) 768-6978  
Fax: (800) 440-7958
3. **Product Description:** A rooftop support with "strut" used to support roof-mounted electrical conduit, solar piping, gas pipes, or other mechanical piping. Pipes rest on a length of hot-dip galvanized steel strut. The pipe support base is made of polycarbonate resin and all other metal parts are made of hot-dip galvanized or stainless-steel.
4. **Product Performance:** The base is gently rounded to allow movement upon the roof to prevent gouging the roof membrane. Each support offers the following clearances above the roof:
  - o 20-Base Strut-4 has a fixed height of 4-1/8 inches.
  - o 20-Base Strut-8 has a factory-set maximum height of 9-1/2 inches with adjustability down to 5-1/2 inches.
  - o 20-Base Strut-18 has a factory-set maximum height of 19 inches with adjustability down to 5-1/2 inches.More than one conduit or pipe may be ganged on the pipe support and attached with typical pipe clamps or clips, so long as the total load weight per support does not exceed recommended weight limit.
5. **Compatibility:** Base Strut Pipestands are recommended and are compatible to use with all current deck types and with all commonly used built-up and single-ply roofing membranes where roof-mounted pipes occur.
6. **Load Weight:** Maximum load weight may not exceed 960 pounds on the 20-Base Strut-4 and the 20-Base Strut-8 pipestands. Maximum load weight may not exceed 717 pounds on the 20-Base Strut-18 pipestand.
7. **Composition and Materials:** The pipestand consists of three major components: (1) A polycarbonate resin deck base, (2) 5/8 inch diameter stainless-steel all thread with hot-dip galvanized hardware, and (3) a 20 inch piece of 1-5/8 x 1-5/8 inch hot-dip galvanized strut. Carbon black is added to the polycarbonate resin for UV-resistance and protection.
8. **Size:** The 20-Base Strut series pipestands have a 19 x 23 inch polycarbonate deck base and a 20 inch piece of 1-5/8 x 1-5/8 inch hot-dip galvanized strut. The 20-Base Strut models provide height adjustability as outlined above.
9. **Installation:** (1) Center the pipestand beneath the pipe so that the strut allows the pipe to be positioned squarely over the pipestand. (2) Adjust the pipestand to the desired height and ensure load is evenly distributed with other pipestands. Make certain the strut is level. (3) Set the pipe on the pipestand without dropping or causing any undue impact.  
  
An additional sheet of roofing material, a traffic pad, or a MIRO Support Pad should be installed beneath the pipestand. For built up roofs, clear all loose aggregate from an area 2 inches outside each base footprint and then follow the installation directions outlined above. Care should be taken to install each pipestand, so each support carries a proportional and equal amount of weight.
10. **Spacing:** Manufacturer's recommended spacing is not to exceed 10-foot centers depending upon the load. Make certain each pipestand is properly elevated and loading is distributed evenly to all pipestands. Support spacing is not to exceed the maximum spacing required in the pipe specifications, where applicable.
11. **Availability:** Base Strut Pipestands are marketed throughout the United States through representatives and distributors.
12. **Maintenance:** Normal maintenance is not required. Semi-annual inspection is required to check pipestand position and set pipe alignment, check proper weight distribution, and to correct improper installation that may cause pipestand damage or failures.
13. **Technical Services:** Please call MIRO INDUSTRIES, INC: (800) 768-6978 or visit our website [www.miroind.com](http://www.miroind.com) for technical information and for graphic and CAD drawing downloads.

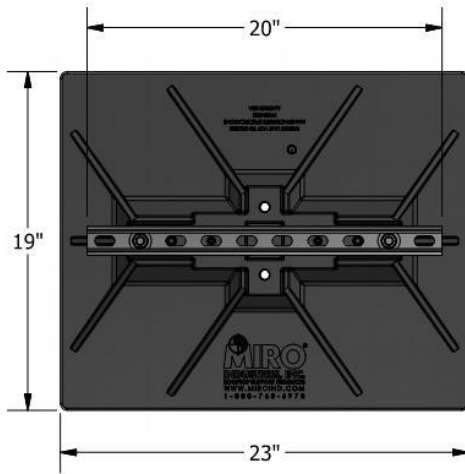

**TOP VIEW**



**ISOMETRIC VIEW**

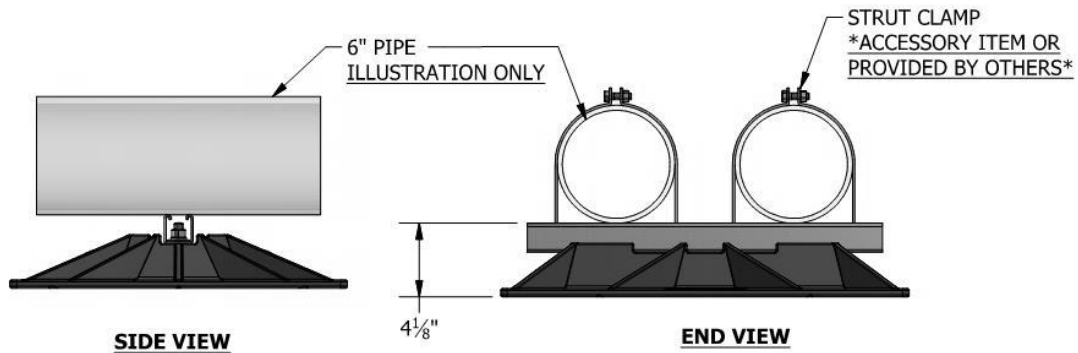

**SIDE VIEW**

**END VIEW**

**ACCESSORIES**

- Strut Clamp - Order to Pipe O.D.
- 19" x 23" Support pad
- Eternabond® 2-sided tape

**PRODUCT DESCRIPTION**

A pipe support with "strut" used to support roof-mounted electrical conduit, solar piping, gas pipes and other mechanical piping. Pipes rest on a 20" length of strut which is mounted on the base. The pipes can be fastened by using the appropriate pipe clamp.

**KEY INFORMATION**

- Designed to support conduit (ganged) cable trays or other mechanical piping.
- Fixed height at 4-1/8"
- Maximum load is 960 lbs. (3.0 psi) Make certain each support is properly elevated to evenly distribute weight at all support locations.
- Unit Weight: 11.02 lbs.
- Recommended spacing is not to exceed 10' centers depending upon the load.
- Base Material: Polycarbonate
- All metal parts are either stainless steel or hot-dip galvanized.

The information contained in this drawing is the sole property of MIRO Industries, Inc. Any reproduction in part or as a whole without written permission of MIRO Industries, Inc. is prohibited.	DATE:	<b>20-BASE STRUT-4</b>
	JAN 2019	

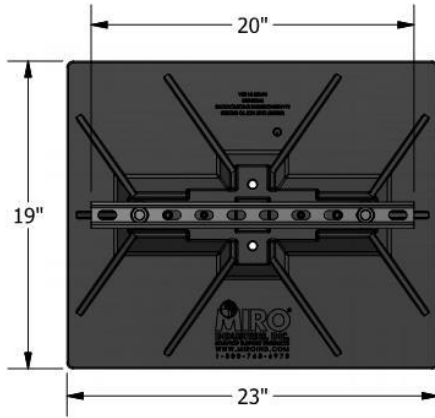

**TOP VIEW**

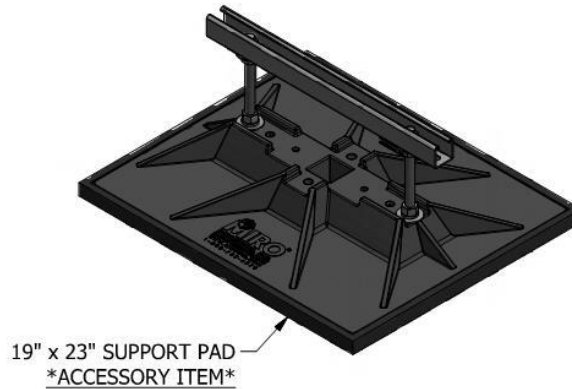

**ISOMETRIC VIEW**

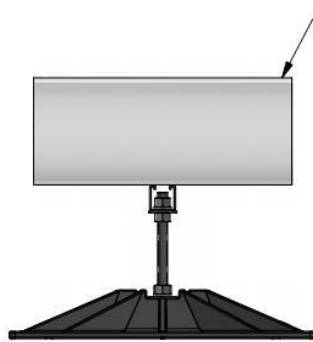

**SIDE VIEW**

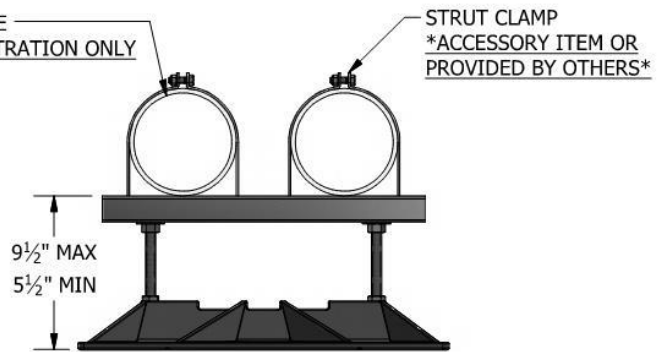

**END VIEW**

**ACCESSORIES**

- Strut Clamp - Order to Pipe O.D.
- 19" x 23" Support pad
- Eternabond® 2-sided tape

**PRODUCT DESCRIPTION**

A pipe support with "strut" used to support roof-mounted electrical conduit, solar piping, gas pipes and other mechanical piping. Pipes rest on a 20" length of strut which is mounted on the base. The pipes can be fastened by using the appropriate pipe clamp.

**KEY INFORMATION**

- Designed to support conduit (ganged) cable trays or other mechanical piping.
- Adjustable from the factory set maximum height of 9-1/2" down to a minimum height of 5-1/2"
- Maximum load is 960 lbs. (3.0 psi) Make certain each support is properly elevated to evenly distribute weight at all support locations.
- Unit Weight: 13.12 lbs.
- Recommended spacing is not to exceed 10' centers depending upon the load.
- Base Material: Polycarbonate
- All metal parts are either stainless steel or hot-dip galvanized.

The information contained in this drawing is the sole property of MIRO Industries, Inc. Any reproduction in part or as a whole without written permission of MIRO Industries, Inc. is prohibited.	DATE:	<b>20-BASE STRUT-8</b>
	JAN 2019	

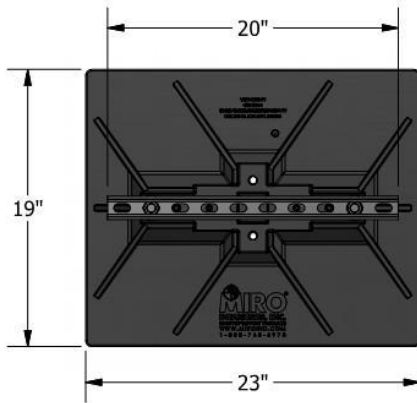

**TOP VIEW**

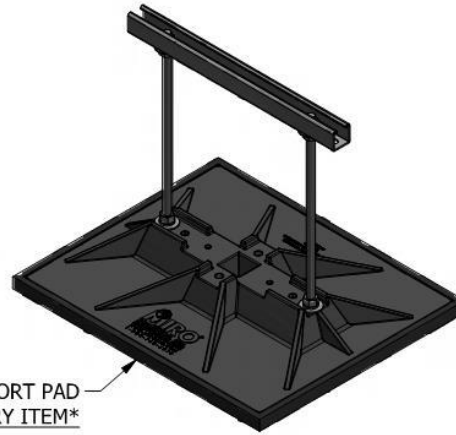

19" x 23" SUPPORT PAD  
\*ACCESSORY ITEM\*

**ISOMETRIC VIEW**



**SIDE VIEW**

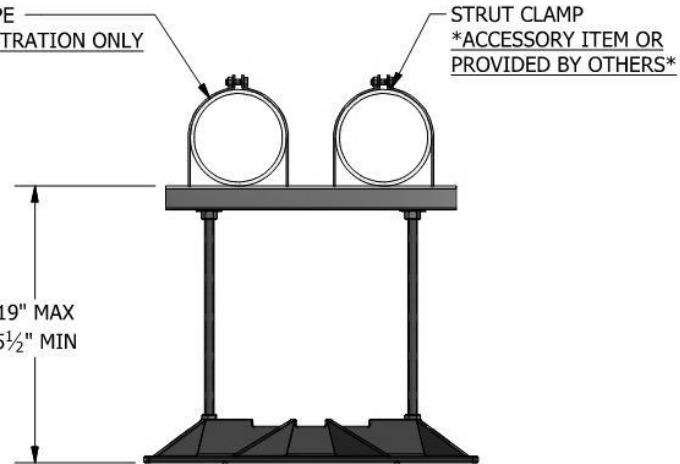

**END VIEW**

**ACCESSORIES**

- Strut Clamp - Order to Pipe O.D.
- 19" x 23" Support pad
- Eternabond® 2-sided tape

**PRODUCT DESCRIPTION**

A pipe support with "strut" used to support roof-mounted electrical conduit, solar piping, gas pipes and other mechanical piping. Pipes rest on a 20" length of strut which is mounted on the base. The pipes can be fastened by using the appropriate pipe clamp.

**KEY INFORMATION**

- Designed to support conduit (ganged) cable trays or other mechanical piping.
- Adjustable from the factory set maximum height of 19" down to a minimum height of 5-1/2"
- Maximum load is 717 lbs. (All-thread capacity) Make certain each support is properly elevated to evenly distribute weight at all support locations.
- Unit Weight: 14.80 lbs.
- Recommended spacing is not to exceed 10' centers depending upon the load.
- Base Material: Polycarbonate
- All metal parts are either stainless steel or hot-dip galvanized.

The information contained in this drawing is the sole property of MIRO Industries, Inc. Any reproduction in part or as a whole without written permission of MIRO Industries, Inc. is prohibited.	DATE:	20-BASE STRUT-18
	JAN 2019	



**Strut Size:**  
24", 36" & 48" Strut  
1-5/8" x 1-5/8"

## Product Data Sheet

# 24-Base Strut-5, 36-Base Strut-5, and 48-Base Strut-5

1. **Product Name:** 20-Base Strut-4, 20-Base Strut-8 and 20-Base Strut-18.
2. **Manufacturer:** MIRO INDUSTRIES, INC.  
844 South 430 West, Suite 100,  
Heber City, Utah 84032  
Phone: (800) 768-6978  
Fax: (800) 440-7958
3. **Product Description:** A rooftop support with "strut" used to support roof-mounted electrical conduit, solar piping, gas pipes, or other mechanical piping. Pipes rest on a length of hot-dip galvanized steel strut. The pipe support base is made of polycarbonate resin and all other metal parts are made of hot-dip galvanized or stainless-steel.
4. **Product Performance:** The base is gently rounded to allow movement upon the roof to prevent gouging the roof membrane. Each support offers the following clearances above the roof:
  - o 24-Base Strut-5 has a factory-set maximum height of 6-1/8 inches with adjustability down to 4-1/8 inches.
  - o 36-Base Strut-5 has a factory-set maximum height of 6-1/8 inches with adjustability down to 4-1/8 inches.
  - o 48-Base Strut-5 has a factory-set maximum height of 6-1/8 inches with adjustability down to 4-1/8 inches.More than one conduit or pipe may be ganged on the pipe support and attached with typical pipe clamps or clips, so long as the total load weight per support does not exceed recommended weight limit.
5. **Compatibility:** Base Strut Pipestands are recommended and are compatible to use with all current deck types and with all commonly used built-up and single-ply roofing membranes where roof-mounted pipes occur.
6. **Load Weight:** Maximum load weight may not exceed a distributed load of 172.5 pounds per foot on the 24-Base Strut-5, 36-Base Strut-5 and the 48-Base Strut-5 pipestands.
7. **Composition and Materials:** The pipestand consists of three major components: (1) two, three or four polycarbonate resin deck bases, (2) 3/8 inch diameter stainless-steel all thread with hot-dip galvanized hardware, and (3) a 24, 36 or 48 inch piece of 1-5/8 x 1-5/8 inch hot-dip galvanized strut. Carbon black is added to the polycarbonate resin for UV-resistance and protection.
8. **Size:** The 24-Base Strut-5, 26-Base Strut-5 and 48-Base Strut-5 pipestands have 7-1/2 x 10 inch polycarbonate deck bases and a length of 1-5/8 x 1-5/8 inch hot-dip galvanized strut. The models provide height adjustability as outlined above.
9. **Installation:** (1) Center the pipestand beneath the pipe so that the strut allows the pipe to be positioned squarely over the pipestand. (2) Adjust the pipestand to the desired height and ensure load is evenly distributed with other pipestands. Make certain the strut is level. (3) Set the pipe on the pipestand without dropping or causing any undue impact.

An additional sheet of roofing material, a traffic pad, or a MIRO Support Pad should be installed beneath the pipestand. For built up roofs, clear all loose aggregate from an area 2 inches outside each base footprint and then follow the installation directions outlined above. Care should be taken to install each pipestand, so each support carries a proportional and equal amount of weight.
10. **Spacing:** Manufacturer's recommended spacing is not to exceed 10-foot centers depending upon the load. Make certain each pipestand is properly elevated and loading is distributed evenly to all pipestands. Support spacing is not to exceed the maximum spacing required in the pipe specifications, where applicable.
11. **Availability:** Base Strut Pipestands are marketed throughout the United States through representatives and distributors.
12. **Maintenance:** Normal maintenance is not required. Semi-annual inspection is required to check pipestand position and set pipe alignment, check proper weight distribution, and to correct improper installation that may cause pipestand damage or failures.
13. **Technical Services:** Please call MIRO INDUSTRIES, INC.: (800) 768-6978 or visit our website [www.miroind.com](http://www.miroind.com) for technical information and for graphic and CAD drawing downloads.



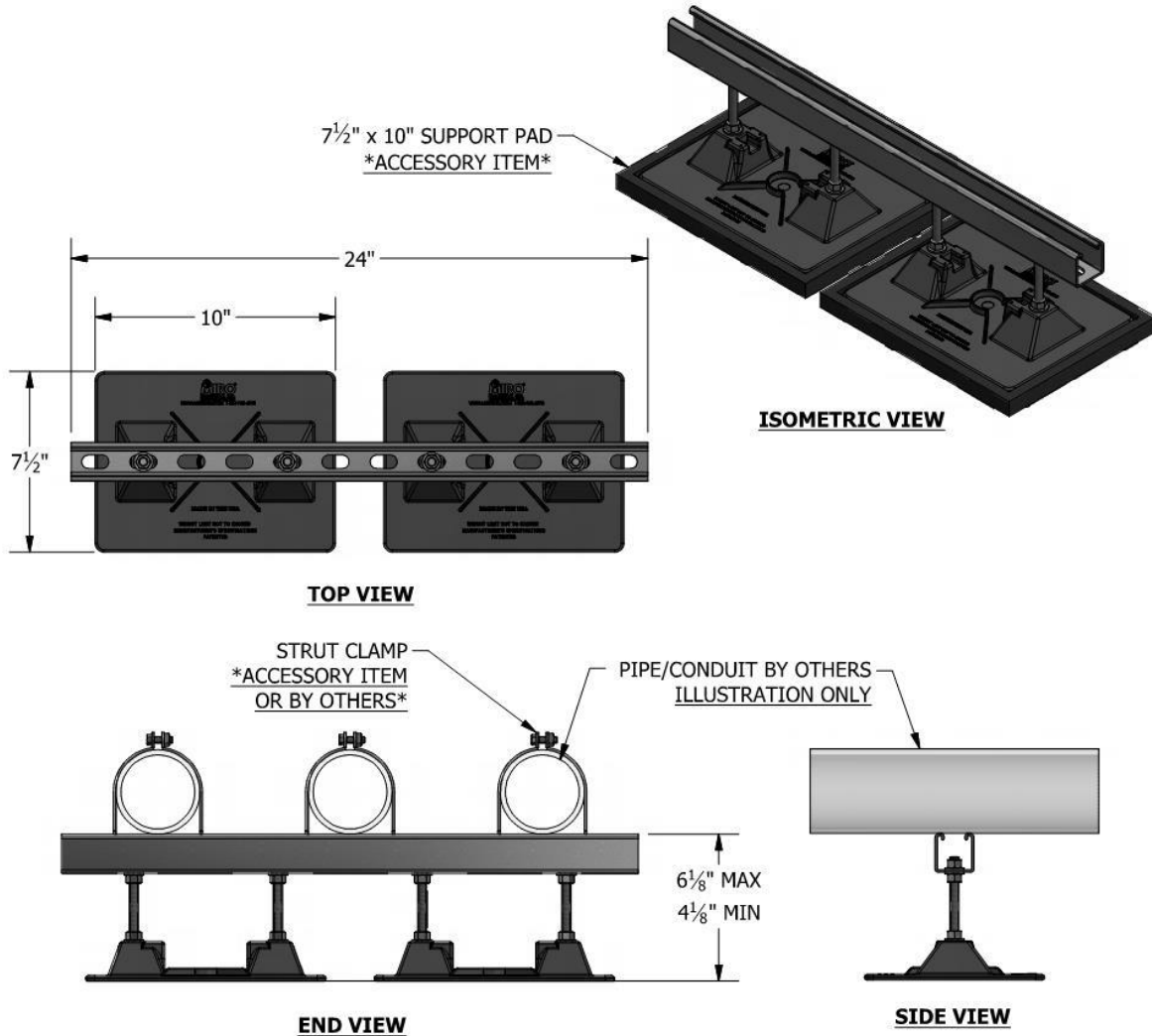

**ACCESSORIES**

- Strut Clamp - Order to Pipe O.D.
- (2) 7 1/2" x 10" Support pads
- Eternabond® 2-sided tape

**PRODUCT DESCRIPTION**

A pipe support with "strut" used to support roof-mounted electrical conduit, solar piping, gas pipes and other mechanical piping. Pipes rest on a 24" length of strut which is mounted on the bases. The pipes can be fastened by using the appropriate pipe clamp.

**KEY INFORMATION**

- Designed to support conduit (ganged) cable trays or other mechanical piping.
- Adjustable from the factory set maximum height of 6-1/8" down to a minimum height of 4-1/8"
- Maximum load is 172.5 lbs/ft. (3.0 psi) Make certain each support is properly elevated to evenly distribute weight at all support locations.
- Unit Weight: 6.11 lbs.
- Recommended spacing is not to exceed 10' centers depending upon the load.
- Base Material: Polycarbonate
- All metal parts are either stainless steel or hot-dip galvanized.

The information contained in this drawing is the sole property of MIRO Industries, Inc. Any reproduction in part or as a whole without written permission of MIRO Industries, Inc. is prohibited.	DATE:	24-BASE STRUT-5
	JAN 2019	

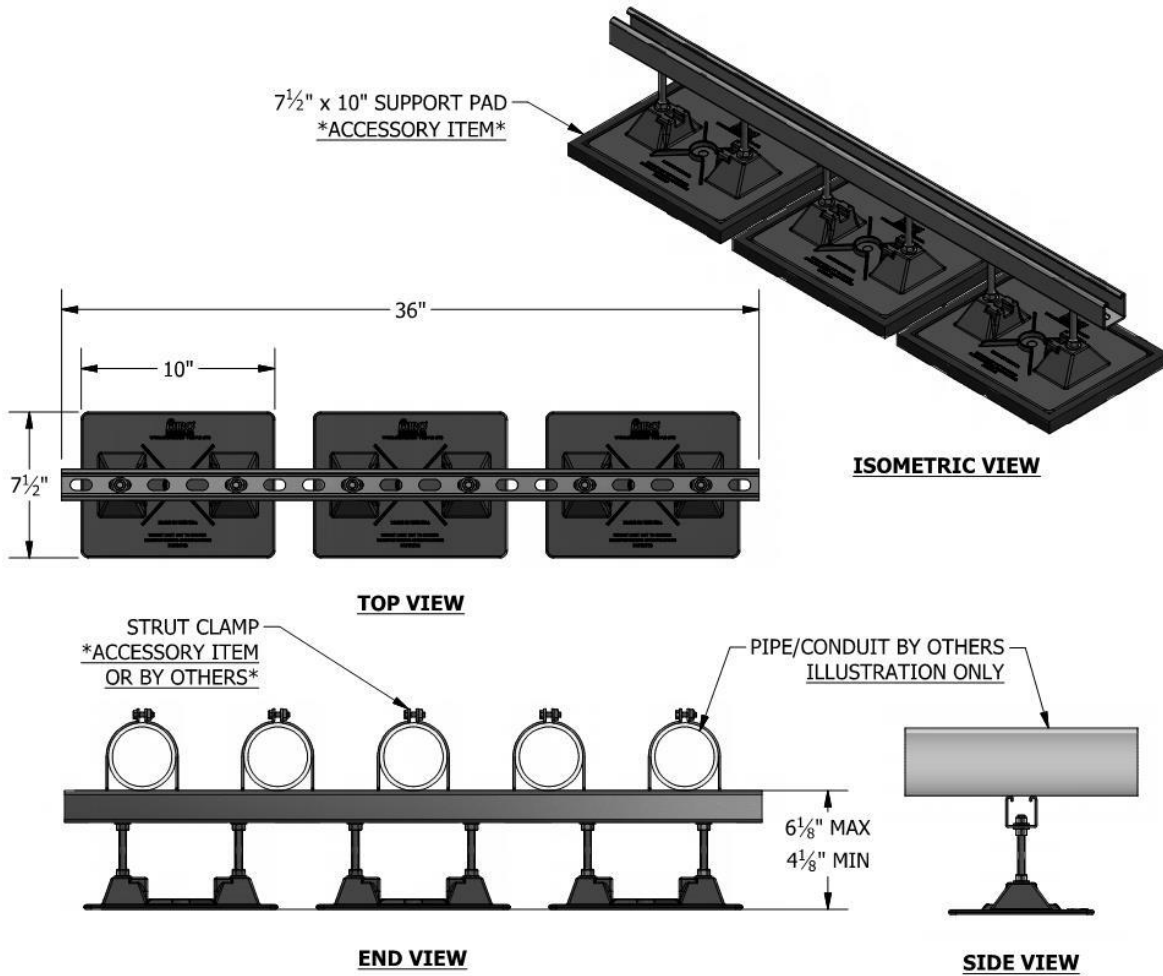

**ACCESSORIES**

- Strut Clamp - Order to Pipe O.D.
- (3) 7 1/2" x 10" Support pads
- Eternabond® 2-sided tape

**PRODUCT DESCRIPTION**

A pipe support with "strut" used to support roof-mounted electrical conduit, solar piping, gas pipes and other mechanical piping. Pipes rest on a 36" length of strut which is mounted on the bases. The pipes can be fastened by using the appropriate pipe clamp.

**KEY INFORMATION**

- Designed to support conduit (ganged) cable trays or other mechanical piping.
- Adjustable from the factory set maximum height of 6-1/8" down to a minimum height of 4-1/8"
- Maximum load is 172.5 lbs/ft. (3.0 psi) Make certain each support is properly elevated to evenly distribute weight at all support locations.
- Unit Weight: 6.11 lbs.
- Recommended spacing is not to exceed 10' centers depending upon the load.
- Base Material: Polycarbonate
- All metal parts are either stainless steel or hot-dip galvanized.

The information contained in this drawing is the sole property of MIRO Industries, Inc. Any reproduction in part or as a whole without written permission of MIRO Industries, Inc. is prohibited.	DATE:	36-BASE STRUT-5
	JAN 2019	

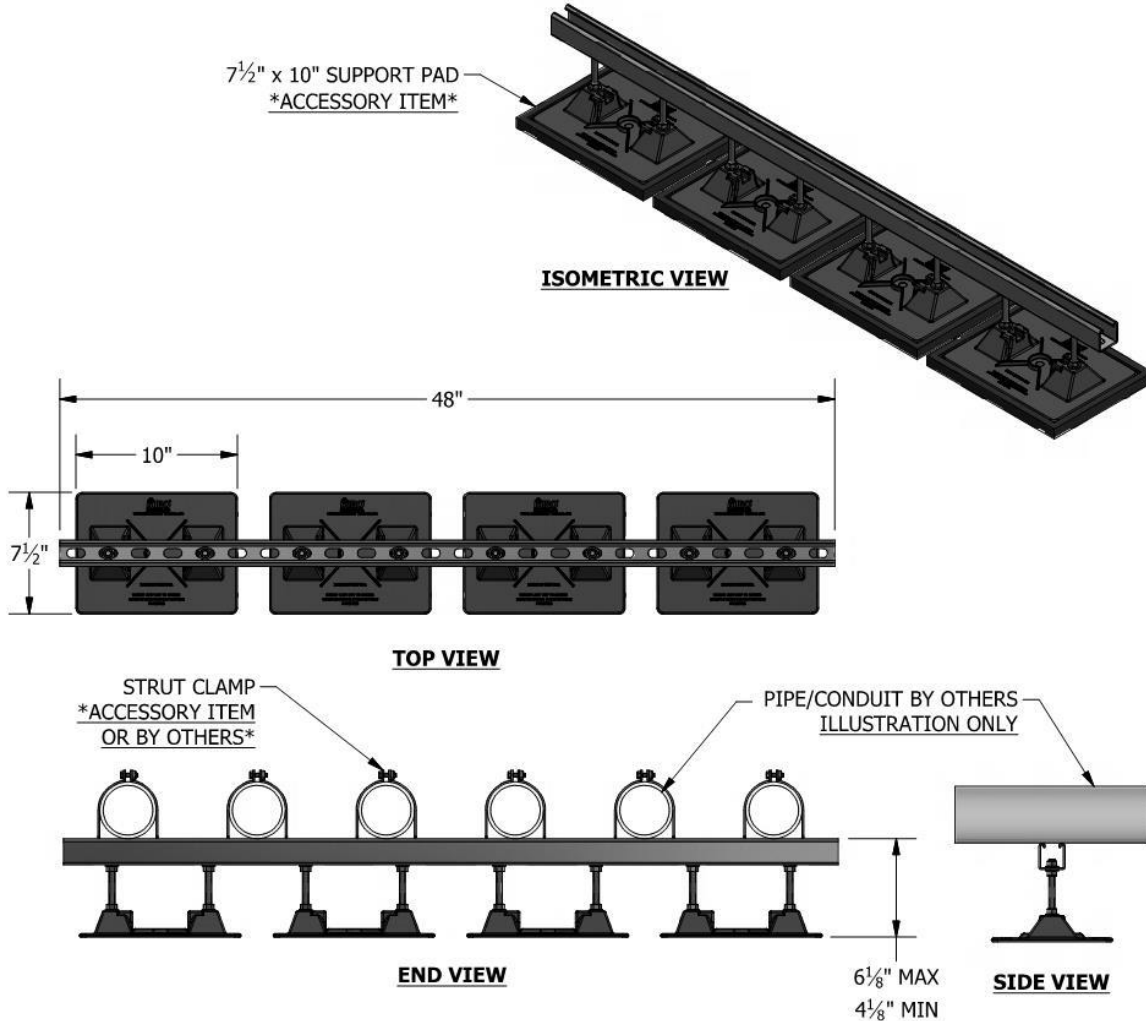

**ACCESSORIES**

- Strut Clamp - Order to Pipe O.D.
- (4)  $7\frac{1}{2}$ " x 10" Support pads
- Eternabond® 2-sided tape

**PRODUCT DESCRIPTION**

A pipe support with "strut" used to support roof-mounted electrical conduit, solar piping, gas pipes and other mechanical piping. Pipes rest on a 48" length of strut which is mounted on the bases. The pipes can be fastened by using the appropriate pipe clamp.

**KEY INFORMATION**

- Designed to support conduit (ganged) cable trays or other mechanical piping.
- Adjustable from the factory set maximum height of  $6\frac{1}{8}$ " down to a minimum height of  $4\frac{1}{8}$ "
- Maximum load is 172.5 lbs/ft. (3.0 psi) Make certain each support is properly elevated to evenly distribute weight at all support locations.
- Unit Weight: 6.11 lbs.
- Recommended spacing is not to exceed 10' centers depending upon the load.
- Base Material: Polycarbonate
- All metal parts are either stainless steel or hot-dip galvanized.

The information contained in this drawing is the sole property of MIRO Industries, Inc. Any reproduction in part or as a whole without written permission of MIRO Industries, Inc. is prohibited.	DATE:	48-BASE STRUT-5
	JAN 2019	





## **CUSTOM HANGER SUPPORTS**

Many projects require the use of custom-designed and engineered components, hardware, bases, and layouts to properly accommodate the varying types of equipment, conduits, ducting, cable trays and piping, as well as the roof topography specific to your job.

MIRO's team of in-house engineers and project managers are dedicated to customized solutions. They are experts in assessing your needs and requirements for your job, then finding the best, quickest and most cost-effective ways to meet them. Our ability to design, engineer and execute intricate, custom projects has made MIRO the go-to leader in the industry.

## Product Data Sheet

### 6H (P), 6H (HDG) and 6H (SS)

1. **Product Name:** CUSTOM HANGER SUPPORT SERIES, 6H (P), 6H (HDG) and 6H (SS).
2. **Manufacturer:** MIRO INDUSTRIES, INC.  
844 South 430 West, Suite 100,  
Heber City, Utah 84032  
Phone: (800) 768-6978  
Fax: (800) 440-7958
3. **Product Description:** A strut-framed support system that will accommodate a variety of options for supporting rooftop piping. Customers can specify the type of hanger to be used based on project requirements. Typical hanger types include clevis hangers, roller hangers, band hangers, trapeze hangers, or roller chair assemblies. Each support has a minimum of 2 bases made of polycarbonate plastic, hot-dip galvanized or stainless-steel. All other parts are hot-dip galvanized or stainless-steel. The pipestand will accommodate single or multiple pipe configurations with vertical adjustability.
4. **Product Performance:** The strut-frame and hanger or roller system provides a means to accommodate thermal expansion and contraction of pipes, thus preventing damage to the supported piping, pipe insulation, the support frame and the roof membrane. The base is gently rounded to prevent gouging the roof membrane.
5. **Compatibility:** MIRO Custom Hanger Pipestands are recommended for use on, and are compatible to use with, all current types of decking and with all commonly used built-up and single-ply roofing membranes where roof-mounted pipes occur.
6. **Loading/Design Constraints:** The 6H series support is built to ensure member and component capacities and deflection criteria are not exceeded. Maximum loading from any MIRO base to the finished roof surface is not to exceed 3.0 psi unless specifically stated in the project specifications. Deflection in the horizontal header bar is not to exceed the span length divided by 360 or 1/8".
7. **Composition and Materials:** The pipestand consists of three major components: (1) a minimum of two polycarbonate plastic (P), hot-dip galvanized (HDG) or stainless-steel (SS) bases which sit on the roof membrane, (2) a hot-dip galvanized or stainless-steel strut frame assembly, which connected to the two bases, and (3) a hanger system consisting of a stainless-steel all-thread rod which suspends a clevis hanger, a roller hanger, a band hanger, or a trapeze hanger from the frame assembly, or a roller chair assembly that will mount directly on the frame header bar.
8. **Size:** The series 6H is made as follows: Each frame has a minimum of two 9 x 15-1/4 inch (P) or 8 x 14 inch (HDG or SS) bases, the legs are 1-5/8 x 7/8 inch slotted 12 gauge strut, and the header bar will be 1-5/8 x 7/8, 1-5/8 x 1-5/8, or 1-5/8 x 3-1/4 inch slotted 12 gauge strut as required for loading. The header bar will have a minimum length of 14 inches to accommodate the bases. The strut frame assembly is constructed to allow vertical adjustment of the pipes within a specified range.
9. **Adjustable Height:** The 6H series and its related configurations allow adjustable heights as desired, or required, by the code or roof system. Cross-bracing two adjacent pipestands is required for elevations 36" and higher. Purchasers must specify desired heights and multiple pipe centerline spacing upon quote requests and ordering of 6H series stands.
10. **Adjustability for Roof Slope:** The 6H series base will accommodate up to a 2:12 (9 degree) roof slope parallel to the pipe run. For steeper pitched roofs contact MIRO Industries.
11. **Installation Process:** (1) Center the pipestand with the appropriate hanger located per the pipe layout. (2) Adjust the frame and hanger systems to the desired height to maintain even-load distribution with other pipestands. Make certain the horizontal support strut is level. (3) Set the pipe in the hanger system without dropping or causing any undue impact.  
  
MIRO recommends an additional sheet of roofing material, or a MIRO Support Pad to be installed beneath each base. For built up roofs, remove all loose aggregate from an area 2 inches larger in width and length than the base or support pad and follow the installation directions outlined above.
12. **Spacing:** Manufacturer's recommended spacing is not to exceed 10-foot centers depending upon the load. Make certain each pipestand is properly elevated and loading is distributed evenly to all pipestands. Support spacing is not to exceed the maximum spacing required in the pipe specifications, where applicable.
13. **Availability:** 6H Custom Hanger Pipestands are marketed throughout the United States through representatives and distributors.
14. **Maintenance:** Normal maintenance is not required. Semi-annual inspection is required to check pipestand position and set pipe alignment, check proper weight distribution, and to correct improper installation which may cause pipestand damage or failure.
15. **Technical Services:** Please call MIRO INDUSTRIES, INC: (800) 768-6978 or visit our website [www.miroind.com](http://www.miroind.com) for technical information and for graphic and CAD drawing downloads.



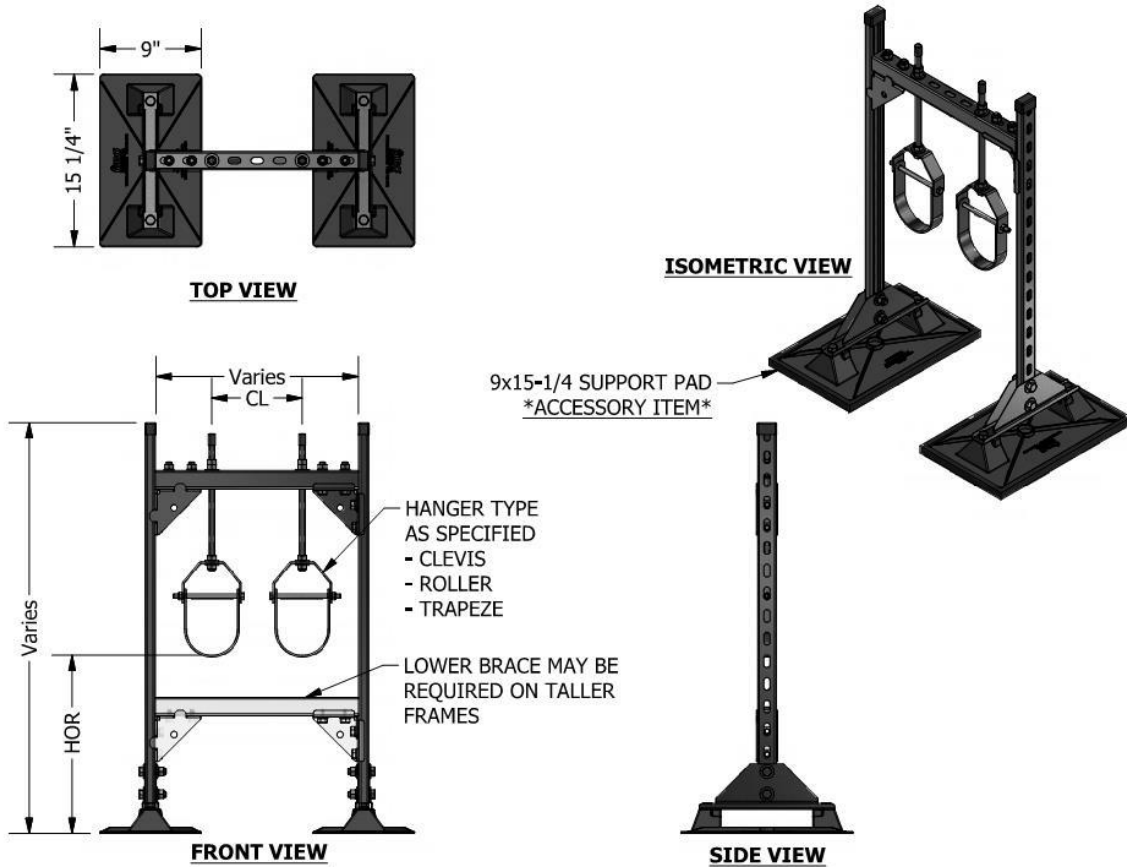

**ACCESSORIES**

- 9 x 15-1/4 Support pad
- Cross bracing

**PRODUCT DESCRIPTION**

Pipe supports for multiple pipes at various heights. To obtain pricing for the 6H model, call your local representative and have the following information available:

1. Specify quantity of supports needed or provide a rooftop pipe layout drawing and MIRO Ind. will provide a quote with a support layout drawing.
2. Type of pipe being supported (Shc. 40 Steel)
3. Pipe sizes (trade size)
4. Pipe content (liquid or gas)
5. Centerline distance between pipes (CL)
6. Height off roof (HOR)
7. Pipe insulation thickness.
8. Preferred hanger type (Clevis, Roller or Trapeze)

**KEY INFORMATION**

- The 6H series support is designed and engineered to project specific requirements provided to MIRO Industries.
- Maximum loading from any MIRO base to the finished roof surface is not to exceed 3.0 psi (335 lbs/base) unless specifically allowed otherwise in the project specification.
- Deflection in the horizontal header bar is not to exceed the span length by 360 or 1/8".
- Frame is designed for gravity loading only.
- Recommended horizontal support spacing is not to exceed 10 feet centers or as required by the applicable design code.
- Contractor is to ensure each pipestand is properly elevated to evenly distribute loading at all pipestands.
- Frame is made with 12 ga slotted strut; Support legs are 7/8"x1-5/8" and header bar is typically 1-5/8" x 1-5/8".
- Base material is polycarbonate
- All metal parts are hot dip galvanized

The information contained in this drawing is the sole property of MIRO Industries, Inc. Any reproduction in part or as a whole without written permission of MIRO Industries, Inc. is prohibited.	DATE:	6H-(#)C P
	JAN 2019	

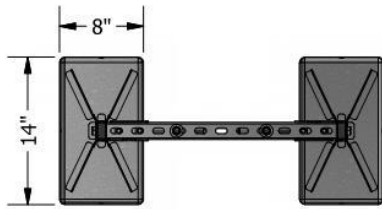

**TOP VIEW**

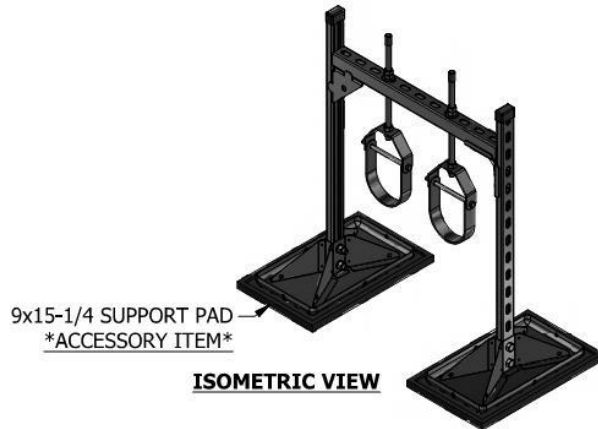

**ISOMETRIC VIEW**

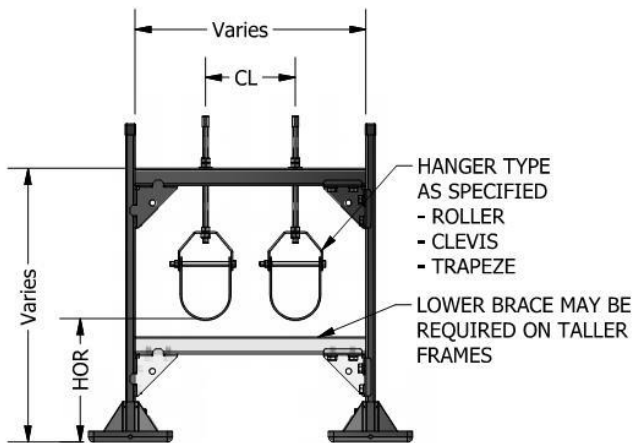

**FRONT VIEW**



**SIDE VIEW**

**ACCESSORIES**

- 9 x 15-1/4 Support pad
- Cross bracing

**PRODUCT DESCRIPTION**

Pipe supports for multiple pipes at various heights. To obtain pricing for the 6H model, call your local representative and have the following information available:

1. Specify quantity of supports needed or provide a rooftop pipe layout drawing and MIRO Ind. will provide a quote with a support layout drawing.
2. Type of pipe being supported. (Sch. 40 Steel)
3. Pipe sizes (trade size)
4. Pipe content (liquid or gas)
5. Centerline distance between pipes (CL)
6. Height off roof (HOR)
7. Pipe insulation thickness.
8. Preferred hanger type (Clevis, Roller or Trapeze)
9. Frame material (Hot-Dip Galvanize or Stainless Steel)

**KEY INFORMATION**

- The 6H HDG/SS series support is designed and engineered to project specific requirements provided to MIRO Industries.
- Maximum loading from any MIRO base to the finished roof surface is not to exceed 3.0 psi (288 lbs/base) unless specifically allowed otherwise in the project specification.
- Deflection in the horizontal header bar is not to exceed the span length by 360 or 1/8".
- Frame is designed for gravity loading only.
- Recommended horizontal support spacing is not to exceed 10 feet centers or as required by the applicable design code.
- Contractor is to ensure each pipestand is properly elevated to evenly distribute loading at all pipestands.
- Frame is made with 12 ga slotted strut; Support legs are 7/8"x1-5/8" and header bar is typically 1-5/8" x 1-5/8".
- All metal parts are hot dip galvanized or stainless steel.

The information contained in this drawing is the sole property of MIRO Industries, Inc. Any reproduction in part or as a whole without written permission of MIRO Industries, Inc. is prohibited.	DATE:	6H-(#)C HDG/SS
	JAN 2019	

## Product Data Sheet

# 8H (P), 8H (HDG) and 8H (SS)

- Product Name:** CUSTOM HANGER SUPPORT SERIES, 8H (P), 6H (HDG) and 6H (SS).
- Manufacturer:** MIRO INDUSTRIES, INC.  
844 South 430 West, Suite 100,  
Heber City, Utah 84032  
Phone: (800) 768-6978  
Fax: (800) 440-7958
- Product Description:** A strut-framed support system that will accommodate a variety of options for supporting rooftop piping. Customers can specify the type of hanger to be used based on project requirements. Typical hanger types include clevis hangers, roller hangers, band hangers, trapeze hangers or roller chair assemblies. Each support has a minimum of 2 bases made of polycarbonate plastic, hot-dip galvanized or stainless-steel. All other parts are hot-dip galvanized or stainless-steel. The pipestand will accommodate single or multiple pipe configurations with vertical adjustability.
- Product Performance:** The strut-frame and hanger or roller system provides a means to accommodate thermal expansion and contraction of pipes, thus preventing damage to the supported piping, pipe insulation, the support frame and the roof membrane. The base is gently rounded to prevent gouging the roof membrane.
- Compatibility:** MIRO Custom Hanger Pipestands are recommended for use on, and are compatible to use with, all current types of decking and with all commonly used built-up and single-ply roofing membranes where roof-mounted pipes occur.
- Loading/Design Constraints:** The 8H series support is built to ensure member and component capacities and deflection criteria are not exceeded. Maximum loading from any MIRO base to the finished roof surface is not to exceed 3.0 psi unless specifically stated in the project specifications. Deflection in the horizontal header bar is not to exceed the span length divided by 360 or 1/8".
- Composition and Materials:** The pipestand consists of three major components: (1) a minimum of two polycarbonate plastic (P), hot-dip galvanized (HDG) or stainless-steel (SS) bases which sit on the roof membrane, (2) a hot-dip galvanized or stainless-steel strut frame assembly, which connected to the two bases, and (3) a hanger system consisting of a stainless-steel all-thread rod which suspends a clevis hanger, a roller hanger, a band hanger, or a trapeze hanger from the frame assembly, or a roller chair assembly that will mount directly on the frame header bar.
- Size:** The series 8H is made as follows: Each frame has a minimum of two 16 x 18 inch (P) or 12 x 16 inch (HDG or SS) bases, the legs are 1-5/8 x 1-5/8 inch slotted 12 gauge strut, and the header bar will be 1-5/8 x 1-5/8 or 1-5/8 x 3-1/4 inch slotted 12 gauge strut as required for loading. The header bar will have a minimum length of 18 inches to accommodate the bases. The strut frame assembly is constructed to allow vertical adjustment of the pipes within a specified range.
- Adjustable Height:** The 8H series and its related configurations allow adjustable height as desired, or required, by the code or roof system. Cross-bracing two adjacent pipestands is required for elevations 36" and higher. Purchasers must specify desired heights and multiple pipe centerline spacing upon quote requests and ordering of 8H series stands.
- Adjustability for Roof Slope:** The 8H series base will accommodate up to a 2:12 (9 degree) roof slope parallel to the pipe run. Where the pipe runs perpendicular to the roof pitch, the leg assembly can be un-assembled from the brackets supporting the header bar, rotated 90 degrees, and re-assembled to the bracket using the alternate side holes and the provided hardware. For steeper pitched roofs contact MIRO Industries.
- Installation Process:** (1) Center the pipestand with the appropriate hanger located per the pipe layout. (2) Adjust the frame and hanger systems to the desired height to maintain even load distribution with the other pipestands. Make certain the horizontal support strut is level. (3) Set the pipe in the hanger system without dropping or causing any undue impact.  
  
MIRO recommends an additional sheet of roofing material, or a MIRO Support Pad be installed beneath each base. For built up roofs, remove all loose aggregate from an area 2 inches larger in width and length than the base or support pad and follow the installation directions outlined above.
- Spacing:** Manufacturer's recommended spacing is not to exceed 10-foot centers, depending upon the load. Make certain each pipestand is properly elevated and loading is distributed evenly to all pipestands. Support spacing is not to exceed the maximum spacing required in the pipe specifications, where applicable.
- Availability:** 8H Custom Hanger Pipestands are marketed throughout the United States through representatives and distributors.
- Maintenance:** Normal maintenance is not required. Semi-annual inspection is required to check pipestand position and set pipe alignment, check proper weight distribution, and to correct improper installation which may cause pipestand damage or failure.
- Technical Services:** Please call MIRO INDUSTRIES, INC: (800) 768-6978 or visit our website [www.miroind.com](http://www.miroind.com) for technical information and for graphic and CAD drawing downloads.



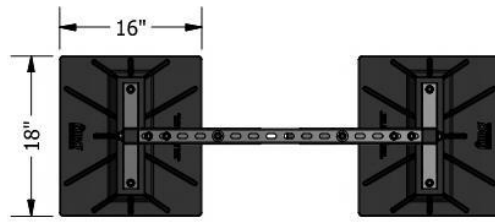

**TOP VIEW**

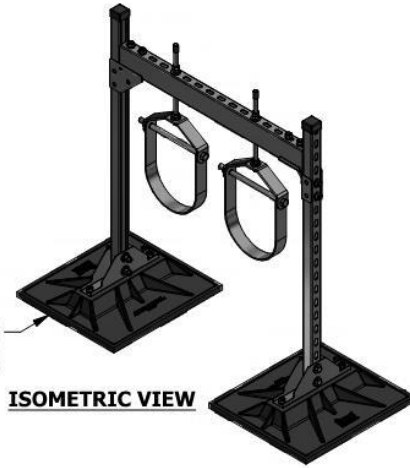

**ISOMETRIC VIEW**

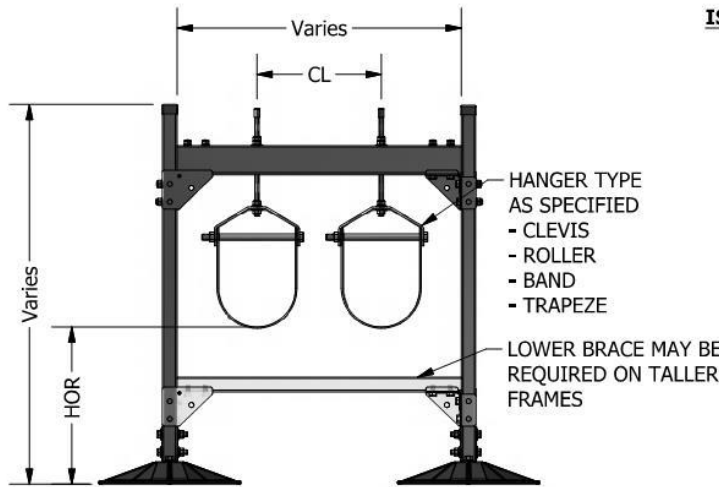

**FRONT VIEW**

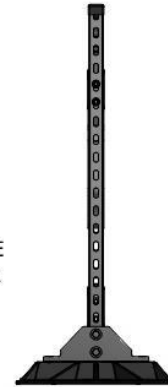

**SIDE VIEW**

16x18 SUPPORT PAD  
\*ACCESSORY ITEM)

HANGER TYPE  
AS SPECIFIED  
- CLEVIS  
- ROLLER  
- BAND  
- TRAPEZE

LOWER BRACE MAY BE  
REQUIRED ON TALLER  
FRAMES

**ACCESSORIES**

- 16 x 18 Support pad
- Cross bracing

**PRODUCT DESCRIPTION**

Pipe supports for multiple pipes at various heights. To obtain pricing for the 8H model, call your local representative and have the following information available:

1. Specify quantity of supports needed or provide a rooftop pipe layout drawing and MIRO Ind. will provide a quote with a support layout drawing.
2. Type of pipe being supported (Sch. 40 Steel)
3. Pipe sizes (trade size)
4. Pipe content (liquid or gas)
5. Centerline distance between pipes (CL)
6. Height off roof (HOR)
7. Pipe insulation thickness.
8. Preferred hanger type (Clevis, Roller, Band or Trapeze)

**KEY INFORMATION**

- The 8H series support is designed and engineered to project specific requirements provided to MIRO Industries.
- Maximum loading from any MIRO base to the finished roof surface is not to exceed 3.0 psi (578 lbs/base) unless specifically allowed otherwise in the project specification.
- Deflection in the horizontal header bar is not to exceed the span length by 360 or 1/8".
- Frame is designed for gravity loading only.
- Recommended horizontal support spacing is not to exceed 10 feet centers or as required by the applicable design code or project specifications.
- Contractor is to ensure each pipestand is properly elevated to evenly distribute loading at all pipestands.
- Frame is made with 12 ga slotted strut; Support legs are 1-5/8"x1-5/8" and header bar is either 1-5/8" x 1-5/8" or 1-5/8"x3-1/4".
- Base material is polycarbonate
- All metal parts are hot dip galvanized

The information contained in this drawing is the sole property of MIRO Industries, Inc. Any reproduction in part or as a whole without written permission of MIRO Industries, Inc. is prohibited.	DATE:	8H-(#)C P
	JAN 2019	

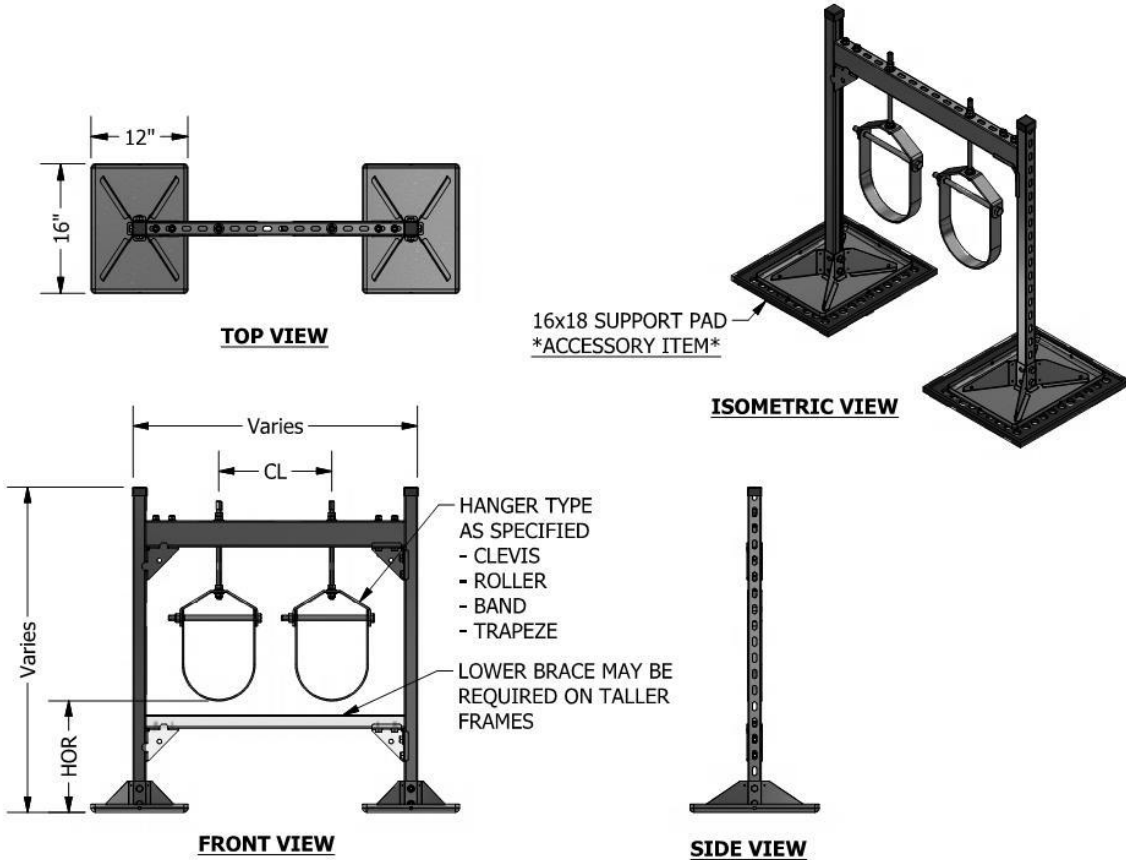

**ACCESSORIES**

- 16 x 18 Support pad
- Cross bracing

**PRODUCT DESCRIPTION**

Pipe supports for a single or multiple pipes at various heights.

To obtain pricing for the 8H model, call your local representative and have the following information available:

1. Specify quantity of supports needed or provide a rooftop pipe layout drawing and MIRO Ind. will provide a quote with a support layout drawing.
2. Type of pipe being supported (Sch. 40 Steel)
3. Pipe sizes (trade size)
4. Pipe content (liquid or gas)
5. Centerline distance between pipes (CL)
6. Height off roof (HOR)
7. Pipe insulation thickness
8. Preferred hanger type (Clevis, Roller, Band or Trapeze)
9. Specify base material (Hot-Dip Galvanized or Stainless Steel)

**KEY INFORMATION**

- The 8H HDG/SS series support is designed and engineered to project specific requirements provided to MIRO Industries.
- Maximum loading from any MIRO base to the finished roof surface is not to exceed 3.0 psi (524 lbs/base) unless specifically allowed otherwise in the project specification.
- Deflection in the horizontal header bar is not to exceed the span length by 360 or 1/8".
- Frame is designed for gravity load only.
- Recommended horizontal support spacing is not to exceed 10 feet centers or as required by the applicable design code or project specifications.
- Contractor is to ensure each pipestand is properly elevated to evenly distribute loading at all pipestands.
- Frame is made with 12 ga slotted strut; Support legs are 1-5/8"x1-5/8" and header bar is either 1-5/8" x 1-5/8" or 1-5/8"x3-1/4".
- All metal parts are hot dip galvanized or stainless steel.

The information contained in this drawing is the sole property of MIRO Industries, Inc. Any reproduction in part or as a whole without written permission of MIRO Industries, Inc. is prohibited.	DATE:	8H-(#)C HDG/SS
	JAN 2019	



## Product Data Sheet

### 10H (P)

1. **Product Name:** CUSTOM HANGER SUPPORT SERIES, 10H (P).
2. **Manufacturer:** MIRO INDUSTRIES, INC.  
844 South 430 West, Suite 100,  
Heber City, Utah 84032  
Phone: (800) 768-6978  
Fax: (800) 440-7958
3. **Product Description:** A strut-framed support system that will accommodate a variety of options for supporting rooftop piping. Customers can specify the type of hanger to be used based on project requirements. Typical hanger types include clevis hangers, roller hangers, band hangers, trapeze hangers or roller chair assemblies. Each support has a minimum of 2 bases made of polycarbonate plastic. All other parts are hot-dip galvanized or stainless-steel. The pipestand will accommodate single or multiple pipe configurations with vertical adjustability.
4. **Product Performance:** The strut-frame and hanger or roller system provides a means to accommodate thermal expansion and contraction of pipes, thus preventing damage to the supported piping, pipe insulation, the support frame and the roof membrane. The base is gently rounded to prevent gouging the roof membrane.
5. **Compatibility:** MIRO Custom Hanger Pipestands are recommended for use on, and are compatible to use with, all current types of decking and with all commonly used built-up and single-ply roofing membranes where roof-mounted pipes occur.
6. **Loading/Design Constraints:** The 10H series support is built to ensure member and component capacities and deflection criteria are not exceeded. Maximum loading from any MIRO base to the finished roof surface is not to exceed 3.0 psi unless specifically stated in the project specifications. Deflection in the horizontal header bar is not to exceed the span length divided by 360 or 1/8".
7. **Composition and Materials:** The pipestand consists of three major components: (1) a minimum of two polycarbonate plastic (P) bases which sit on the roof membrane, (2) a hot-dip galvanized or stainless-steel strut frame assembly, which connected to the two bases, and (3) a hanger system consisting of a stainless-steel all-thread rod which suspends a clevis hanger, a roller hanger, a band hanger, or a trapeze hanger from the frame assembly, or a roller chair assembly that will mount directly on the frame header bar.
8. **Size:** The series 10H is made as follows: Each frame has a minimum of two 19 x 23 inch bases, the legs are 1-5/8 x 1-5/8 inch slotted 12 gauge strut legs, and the header bar will be 1-5/8 x 1-5/8 or 1-5/8 x 3-1/4 inch slotted 12 gauge strut as required for loading. The header bar will have a minimum length of 24 inches to accommodate the bases. The strut frame assembly is constructed to allow vertical adjustment of the pipes within a specified range.
9. **Adjustable Height:** The 10H series, and its related configurations, allow for adjustable heights as desired, or required, by the code or roof system. Cross-bracing two adjacent pipestands is required for elevations 36 inches and higher. Purchasers must specify desired heights and multiple pipe centerline spacing upon quote requests and ordering of 10H series stands.
10. **Adjustability for Roof Slope:** The 8H series base will accommodate up to a 2:12 (9 degree) roof slope parallel to the pipe run. Where the pipe runs perpendicular to the roof pitch, the leg assembly can be un-assembled from the brackets supporting the header bar, rotated 90 degrees and re-assembled to the bracket using the alternate side holes and the provided hardware. For steeper pitched roofs contact MIRO Industries.
11. **Installation Process:** (1) Center the pipestand with the appropriate hanger per the pipe layout. (2) Adjust the frame and hanger systems to the desired height to maintain even load distribution with the other pipestands. Make certain the horizontal support strut is level. (3) Set the pipe in the hanger system without dropping or causing any undue impact.  
  
MIRO recommends an additional sheet of roofing material, or a MIRO Support Pad be installed beneath each base. For built up roofs, remove all loose aggregate from an area 2 inches larger in width and length than the base or support pad, and follow the installation directions outlined above.
12. **Spacing:** Manufacturer's recommended spacing is not to exceed 10-foot centers depending upon the load. Make certain each pipestand is properly elevated and loading is distributed evenly to all pipestands. Support spacing is not to exceed the maximum spacing required in the pipe specifications, where applicable.
13. **Availability:** 10H Custom Hanger Pipestands are marketed throughout the United States through representatives and distributors.
14. **Maintenance:** Normal maintenance is not required. Semi-annual inspection is required to check pipestand position and set pipe alignment, check proper weight distribution, and to correct improper installation that may cause pipestand damage or failure.
15. **Technical Services:** Please call MIRO INDUSTRIES, INC: (800) 768-6978 or visit our website [www.miroind.com](http://www.miroind.com) for technical information and for graphic and CAD drawing downloads.

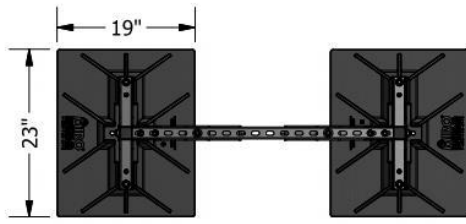

**TOP VIEW**

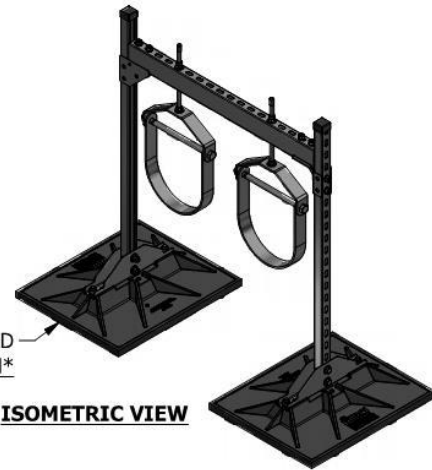

**ISOMETRIC VIEW**

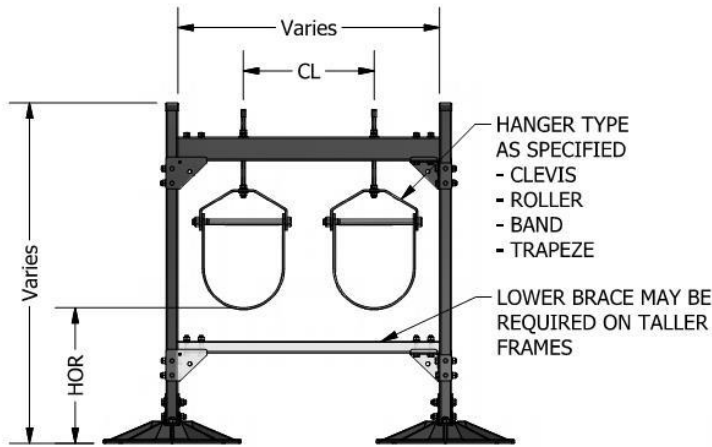

**FRONT VIEW**

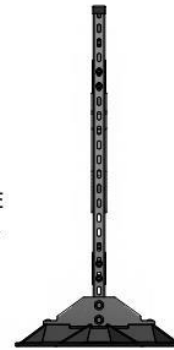

**SIDE VIEW**

**ACCESSORIES**

- 19 x 23 Support pad
- Cross bracing

**PRODUCT DESCRIPTION**

Pipe supports for multiple pipes at various heights. To obtain pricing for the 10H model, call your local representative and have the following information available:

1. Specify quantity of supports needed or provide a rooftop pipe layout drawing and MIRO Ind. will provide a quote with a support layout drawing.
2. Type of pipe being supported (Sch. 40 Steel)
3. Pipe sizes (trade size)
4. Pipe content (liquid or gas)
5. Centerline distance between pipes (CL)
6. Height off roof (HOR)
7. Pipe insulation thickness
8. Preferred hanger type (Clevis, Roller, Band or Trapeze)

**KEY INFORMATION**

- The 10H series support is designed and engineered to project specific requirements provided to MIRO Industries.
- Maximum loading from any MIRO base to the finished roof surface is not to exceed 3.0 psi (960 lbs/base) unless specifically allowed otherwise in the project specification.
- Deflection in the horizontal header bar is not to exceed the span length by 360 or 1/8".
- Frame is designed for gravity loading only.
- Recommended horizontal support spacing is not to exceed 10 feet centers or as required by the applicable design code or project specifications.
- Contractor is to ensure each pipestand is properly elevated to evenly distribute loading at all pipestands.
- Frame is made with 12 ga slotted strut; Support legs are 1-5/8"x1-5/8" and header bar is either 1-5/8" x 1-5/8" or 1-5/8"x3-1/4".
- Base material is polycarbonate
- All metal parts are hot dip galvanized

The information contained in this drawing is the sole property of MIRO Industries, Inc. Any reproduction in part or as a whole without written permission of MIRO Industries, Inc. is prohibited.	DATE:	10H-(#)C P
	JAN 2019	



## **CUSTOM DUCT SUPPORTS**

MIRO Industries duct supports are a simple and long-lasting solution to reliably support rooftop ductwork or cable tray systems. They are available in multiple configurations for side-by-side duct, stacked duct, enclosed duct supports, and more.

They are built using hot-dipped galvanized steel and use a unique MIRO bracket that allows the support to easily be adjusted to accommodate roof slope. The bases are made of UV-stable polycarbonate, and therefore they will not dry out, crack, or crumble like foam, rubber, or polypropylene.

## Product Data Sheet

### 6DS (P), 6DS (HDG) and 6DS (SS)

1. **Product Name:** Custom 6DS adjustable height support. All 6DS supports are custom manufactured at the MIRO Industries plant.
2. **Design Emphasis:** The 6DS, or "H" type, support is a versatile, custom product designed to support single or stacked duct, cable trays, or other rooftop components, at varying heights and widths with onsite vertical adjustability for maximum efficiency and cost savings to customers, contractors, and owners. The frame structure consists of at least two load-distributing bases with vertical strut legs and a horizontal strut header. Support sizes are to be determined for project-specific requirements and allow for a range of vertical adjustability. Horizontal cross-bracing between adjacent frames may be required.
3. **Manufacturer:** MIRO INDUSTRIES, INC. Phone: (800) 768-6978  
844 South 430 West, Suite 100, Fax: (800) 440-7958  
Heber City, Utah 84032
4. **Product Description:** A frame constructed of strut and MIRO's patented bases are used to support duct or various utilities on roofs with slopes up to 2 vertical units and 12 horizontal units, or up to a 9 degree slope. Each support has a minimum of 2 bases made of polycarbonate plastic, hot-dip galvanized or stainless-steel. All other parts are hot-dip galvanized or stainless-steel.
5. **Product Performance:** The frame system serves to keep the duct, or various utility system, directly over the frame without binding and allows for some lateral expansion of the supported system. The base is gently rounded to prevent gouging. Drainage ports are provided to prevent ponding within the device.
6. **Compatibility:** MIRO Custom 6DS supports are recommended for use on, and are compatible to use with, all current types of decking and with all commonly used built-up and single-ply roofing membranes where roof-mounted utilities occur. With heavier loads, it is prudent to use a MIRO Support Pad or other traffic pad to further protect the roof membrane.
7. **Loading/Design Constraints:** The 6DS series support is built to ensure member and component capacities and deflection criteria are not exceeded. Maximum loading from any MIRO base to the finished roof surface is not to exceed 3.0 psi unless specifically stated in the project specifications. Deflection in the horizontal header bar is not to exceed the span length divided by 360 or 1/8".
8. **Composition and Materials:** The 6DS support consists of two major components: (1) a minimum of two polycarbonate plastic (P), hot-dip galvanized (HDG) or stainless-steel (SS) bases which sit on the roof membrane and (2) a hot-dip galvanized or stainless-steel strut frame assembly which is supported by, rests upon and is connected to the two bases.
9. **Size:** The series 6DS is made as follows: Each of the deck bases are 9 x 15-1/4 inch (P) or 8 x 14 inch (HDG or SS), 1-5/8 x 7/8 inch strut legs and a 1-5/8 inch header bar. The header bar may be 7/8, 1-5/8 or 3-1/4 inches tall as required for loading. The header bar will have a minimum length of 14 inches to accommodate the bases. The strut frame assembly is constructed to allow vertical adjustment of the header bar within a specified range.
10. **Adjustable Height:** The 6DS support allows for height adjustments as desired or required by the code or roof system. Cross-bracing two adjacent supports is required for elevations 36" and higher. Purchasers must specify desired heights and multiple duct configuration upon quote requests and ordering of 6DS series stands.
11. **Installation Process:** (1) Center the support directly below the location of the component to be supported. (2) Adjust the header bar to the desired height to maintain even-load weight distribution among the other stands. Make certain the header bar is level. (3) Set the components to be supported onto the frame without dropping or causing any undue impact.  
  
MIRO recommends an additional sheet of roofing material, or a MIRO Support Pad be installed beneath each base. For built up roofs, remove all loose aggregate from an area 2 inches larger in width and length than the base or support pad and follow the installation directions outlined above.
12. **Spacing:** Manufacturer's recommended spacing is not to exceed 8-foot centers depending upon the load. Make certain each pipestand is properly elevated and loading is distributed evenly to all pipestands. Support spacing is not to exceed the maximum spacing required in the component specifications, where applicable.
13. **Availability:** 6DS Supports are marketed throughout the United States through representatives and distributors.
14. **Maintenance:** Normal maintenance is not required. Semi-annual inspection is required to check frame position and set component alignment, check proper weight distribution, and to correct improper installation that may cause pipestand damage or failure.
15. **Technical Services:** Please call MIRO INDUSTRIES, INC: (800) 768-6978 or visit our website [www.miroind.com](http://www.miroind.com) for technical information and for graphic and CAD drawing downloads.



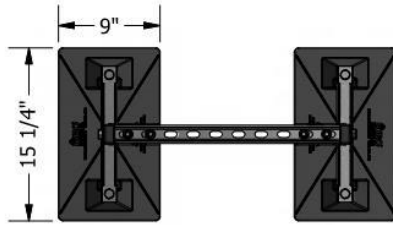

**Top View**

9x15-1/4 SUPPORT PAD  
\*ACCESSORY ITEM\*

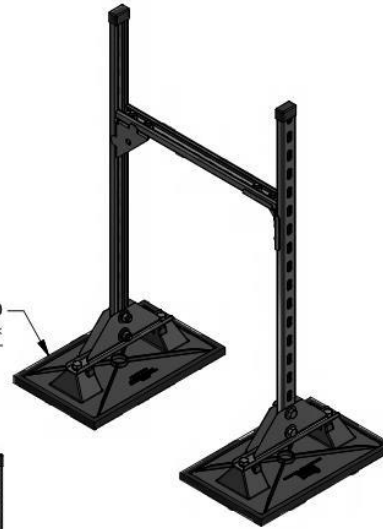

**Isometric View**

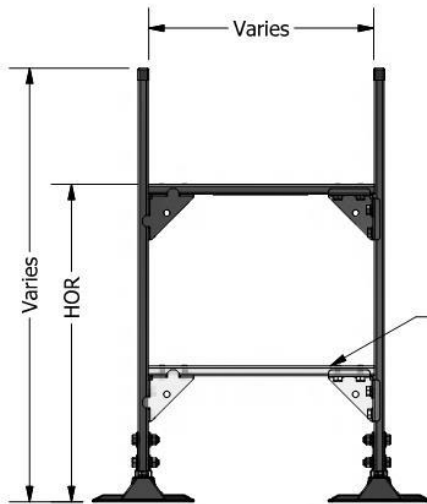

**Front View**

LOWER BRACE MAY BE  
REQUIRED ON TALLER  
FRAMES



**Side View**

**ACCESSORIES**

- 9 x 15-1/4 Support pad
- Cross bracing

**PRODUCT DESCRIPTION**

Duct and Cable Trays are designed for single or multiple duct supports and cable trays.

To obtain pricing for the 6DS model, call your local representative and have the following information available:

1. Specify number of supports needed or provide a roof top duct layout drawing and MIRO Ind. will provide a support layout drawing and take off.
2. Outside Dimensions of duct (Width x Height)
3. Duct material (gauge thickness)
4. Clearance height above roof (HOR)
5. Exterior insulation thickness (if any)
6. Does the duct need to be enclosed?

**KEY INFORMATION**

- The 6DS series support is engineered to ensure member/component capacities and deflection criteria are not exceeded.
- Maximum loading from any MIRO base to the finished roof surface is not to exceed 3.0 psi (335 lbs/base) unless specifically allowed otherwise in the project specifications.
- Deflection in the horizontal header bar is not to exceed the span length by 360 or 1/8".
- Frame is designed for gravity loading only.
- Recommended spacing is not to exceed 8 feet centers depending upon the load.
- Width and height are built job specific based on information provided to MIRO Ind. with a minimum height of 12"
- Frame is made with 12 Gauge Channel; size is determined during design
- Base Material: Polycarbonate
- All metal parts are hot dip galvanized

The information contained in this drawing is the sole property of MIRO Industries, Inc. Any reproduction in part or as a whole without written permission of MIRO Industries, Inc. is prohibited.	DATE:	6DS P
	JAN 2019	



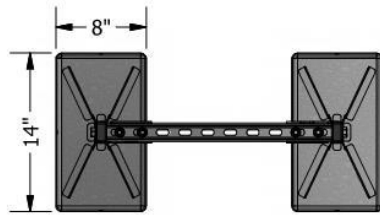

**Top View**

9x15-1/4 SUPPORT PAD  
\*ACCESSORY ITEM\*

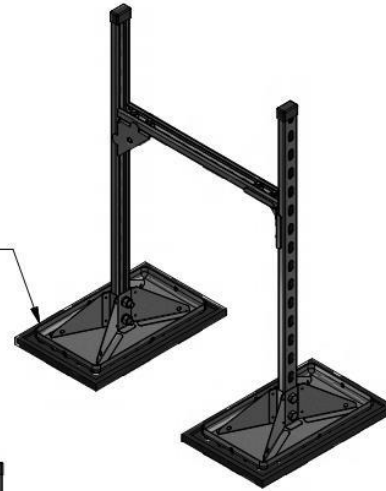

**Isometric View**

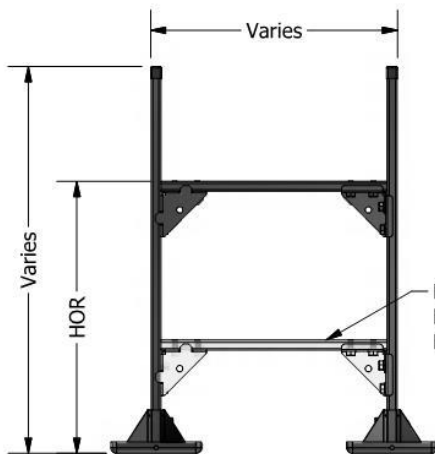

**Front View**

LOWER BRACE MAY BE  
REQUIRED ON TALLER  
FRAMES



**Side View**

**ACCESSORIES**

- 9 x 15-1/4 Support Pad
- Cross Bracing

**PRODUCT DESCRIPTION**

Duct and Cable Trays are designed for single or multiple duct supports and cable trays. To obtain pricing for the 6DS model, call your local representative and have the following information available:

1. Specify number of supports needed or provide a roof top duct layout drawing and MIRO Ind. will provide a support layout drawing and take off.
2. Dimensions of duct (Width x Height, or Diam)
3. Duct material (gauge thickness)
4. Clearance height above roof (HOR)
5. Exterior insulation thickness (if any)
6. Does duct need to be enclosed?

**KEY INFORMATION**

- The 6DS series support is engineered to ensure member/component capacities and deflection criteria are not exceeded.
- Maximum loading from any MIRO base to the finished roof surface is not to exceed 3.0 psi (288 lbs/base) unless specifically allowed otherwise in the project specifications.
- Deflection in the horizontal header bar is not to exceed the span length by 360 or 1/8".
- Frame is designed for gravity loading only.
- Recommended spacing is not to exceed 8 feet centers depending upon the load.
- Width and height are built job specific based on information provided to MIRO Ind. with a minimum height of 12".
- Frame is made with 12 Gauge Channel; size is determined during design.
- Base Material: Hot dip galvanized or stainless steel
- All metal parts are hot dip galvanized or stainless steel

The information contained in this drawing is the sole property of MIRO Industries, Inc. Any reproduction in part or as a whole without written permission of MIRO Industries, Inc. is prohibited.	DATE:	6DS HDG/SS
	JAN 2019	

## Product Data Sheet

### 8DS (P), 8DS (HDG) and 8DS (SS)

- Product Name:** Custom 8DS adjustable height support. All 8DS supports are custom manufactured at the MIRO Industries plant.
- Design Emphasis:** The 8DS, or "H" type support is a versatile, custom product designed to support single or stacked duct, cable trays, or other rooftop components, at varying heights and widths with onsite vertical adjustability for maximum efficiency and cost savings to customers, contractors, and owners. The frame structure consists of at least two load-distributing bases with vertical strut legs and a horizontal strut header. Supports sizes are to be determined for project specific requirements and allow for a range of vertical adjustability. Horizontal cross-bracing between adjacent frames may be required.
- Manufacturer:** MIRO INDUSTRIES, INC. Phone: (800) 768-6978  
844 South 430 West, Suite 100, Fax: (800) 440-7958  
Heber City, Utah 84032
- Product Description:** A frame constructed of strut and MIRO's patented bases are used to support duct or various utilities on roofs with slopes up to 2 vertical units and 12 horizontal units or up to a 9-1/2 degree slope. Each support has a minimum of 2 bases made of polycarbonate plastic, hot-dip galvanized or stainless-steel. All other parts are hot-dip galvanized or stainless-steel.
- Product Performance:** The frame system serves to keep the duct, or various utility system, directly over the frame without binding and allows for some lateral expansion of the supported system. The base is gently rounded to prevent gouging. Drainage ports are provided to prevent ponding within the device.
- Compatibility:** MIRO Custom 8DS supports are recommended for use on, and are compatible to use with, all current types of decking and with all commonly used built-up and single-ply roofing membranes where roof-mounted utilities occur. With heavier loads, it is prudent to use a MIRO Support Pad or other traffic pad to further protect the roof membrane.
- Loading/Design Constraints:** The 8DS series support is built to ensure member and component capacities and deflection criteria are not exceeded. Maximum loading from any MIRO base to the finished roof surface is not to exceed 3.0 psi unless specifically stated in the project specifications. Deflection in the horizontal header bar is not to exceed the span length divided by 360 or 1/8".
- Composition and Materials:** The 8DS support consists of two major components: (1) a minimum of two polycarbonate plastic (P), hot-dip galvanized (HDG) or stainless-steel (SS) bases which sit on the roof membrane and (2) a hot-dip galvanized or stainless-steel strut frame assembly, which is supported by, rests upon and is connected to the two bases.
- Size:** The series 8DS is made as follows: Each of the deck bases are 16 x 18 inch (P) or 12 x 16 inch (HDG or SS), 1-5/8 x 1-5/8 inch strut legs and a 1-5/8 inch header bar. The header bar may be 7/8, 1-5/8 or 3-1/4 inches tall as required for loading. The header bar will have a minimum length of 18 inches to accommodate the bases. The strut frame assembly is constructed to allow vertical adjustment of the header bar within a specified range.
- Adjustable Height:** The 8DS support allows for height adjustments as desired or required by the code or roof system. Cross-bracing two adjacent supports is required for elevations 36" and higher. Purchasers must specify desired heights and multiple duct configuration upon quote requests and ordering of 8DS series stands.
- Installation Process:** (1) Center the support directly below the location of the component to be supported. (2) Adjust the header bar to the desired height to maintain even-load weight distribution among the other stands. Make certain the header bar is level. (3) Set the components to be supported onto the frame without dropping or causing any undue impact.  
  
MIRO recommends an additional sheet of roofing material, or a MIRO Support Pad be installed beneath each base. For built up roofs, remove all loose aggregate from an area 2 inches larger in width and length than the base or support pad and follow the installation directions outlined above.
- Spacing:** Manufacturer's recommended spacing is not to exceed 8-foot centers depending upon the load. Make certain each pipestand is properly elevated and loading is distributed evenly to all pipestands. Support spacing is not to exceed the maximum spacing required in the component specifications, where applicable.
- Availability:** 8DS Supports are marketed throughout the United States through representatives and distributors.
- Maintenance:** Normal maintenance is not required. Semi-annual inspection is required to check frame position and set component alignment, check proper weight distribution, and to correct improper installation which may cause pipestand damage or failure.
- Technical Services:** Please call MIRO INDUSTRIES, INC: (800) 768-6978 or visit our website [www.miroind.com](http://www.miroind.com) for technical information and for graphic and CAD drawing downloads.

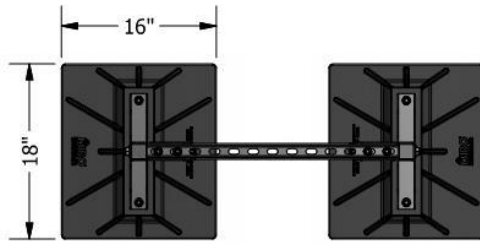

**Top View**

16x18 SUPPORT PAD  
\*ACCESSORY ITEM\*



**Isometric View**

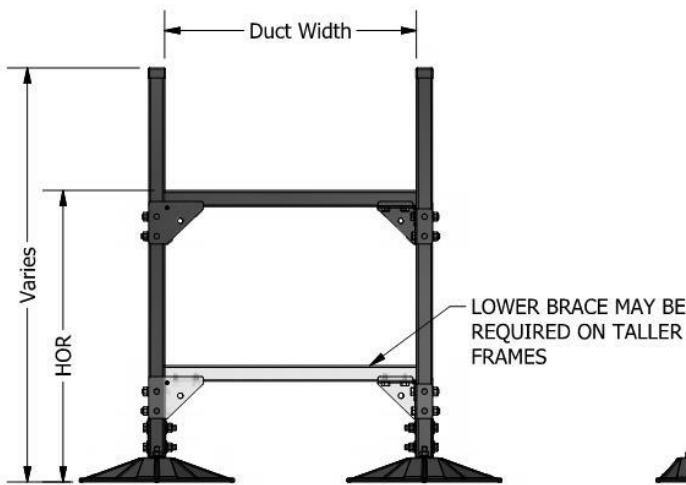

**Front View**



**Side View**

**ACCESSORIES**

- 16 x 18 Support pad
- Cross bracing

**PRODUCT DESCRIPTION**

Duct and Cable Trays are designed for single or multiple duct supports and cable trays. To obtain pricing for the 8DS model, call your local representative and have the following information available:

1. Specify number of supports needed or provide a roof top duct layout drawing and MIRO Ind. will provide a support layout drawing and take off.
2. Dimensions of duct (Width x Height, or Diam)
3. Duct material (gauge thickness)
4. Clearance height above roof (HOR)
5. Exterior insulation thickness (if any)
6. Does duct need to be enclosed?

**KEY INFORMATION**

- The 8DS series support is engineered to ensure member/component capacities and deflection criteria are not exceeded.
- Maximum loading from any MIRO base to the finished roof surface is not to exceed 3.0 psi (578 lbs/base) unless specifically allowed otherwise in the project specifications.
- Deflection in the horizontal header bar is not to exceed the span length by 360 or 1/8".
- Frame is designed for gravity loading only.
- Recommended spacing is not to exceed 8 feet centers depending upon the load.
- Width and height are built job specific based on information provided to MIRO Ind. with a minimum height of 12".
- Frame is made with 12 Gauge Channel; size is determined during design.
- Base Material: Polycarbonate
- All metal parts are hot dip galvanized

The information contained in this drawing is the sole property of MIRO Industries, Inc. Any reproduction in part or as a whole without written permission of MIRO Industries, Inc. is prohibited.	DATE:	8DS P
	JAN 2019	

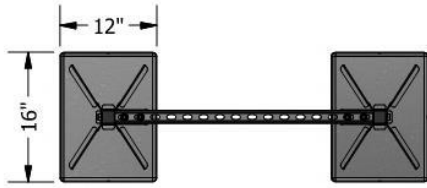

**Top View**



**Isometric View**

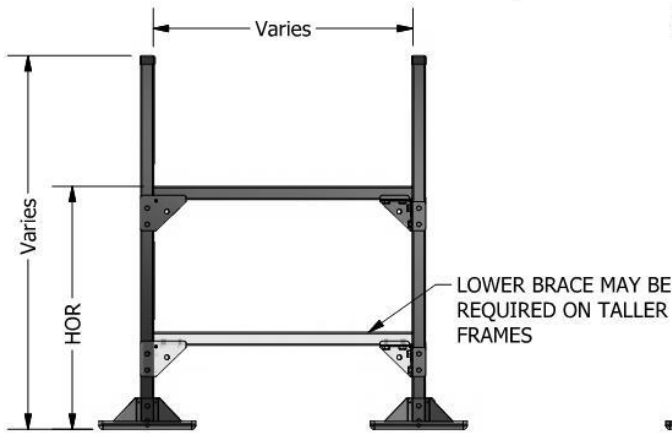

**Front View**



**Side View**

**ACCESSORIES**

- 16 x 18 Support Pad
- Cross bracing

**PRODUCT DESCRIPTION**

Duct and Cable Trays are designed for single or multiple duct supports and cable trays. To obtain pricing for the 8DS model, call your local representative and have the following information available:

1. Specify number of supports needed or provide a roof top duct layout drawing and MIRO Ind. will provide a support layout drawing and take off.
2. Dimensions of duct (Width x Height or Diam)
3. Duct material (gauge thickness)
4. Clearance height above roof (HOR)
5. Exterior insulation thickness (if any)
6. Does duct need to be enclosed?

**KEY INFORMATION**

- The 8DS series support is engineered to ensure member/component capacities and deflection criteria are not exceeded.
- Maximum loading from any MIRO base to the finished roof surface is not to exceed 3.0 psi (529 lbs/base) unless specifically allowed otherwise in the project specifications.
- Deflection in the horizontal header bar is not to exceed the span length by 360 or 1/8".
- Frame is designed for gravity loading only.
- Recommended spacing is not to exceed 8 feet centers depending upon the load.
- Width and height are built job specific based on information provided to MIRO Ind. with a minimum height of 12"
- Frame is made with 12 Gauge Channel; size is determined during design.
- Base Material: Hot dip galvanized or stainless steel.
- All metal parts are hot dip galvanized or stainless steel

The information contained in this drawing is the sole property of MIRO Industries, Inc. Any reproduction in part or as a whole without written permission of MIRO Industries, Inc. is prohibited.	DATE:	8DS HDG/SS
	JAN 2019	



## Product Data Sheet

# 10DS (P)

1. **Product Name:** Custom 10DS adjustable height support. All 10DS supports are manufactured custom at the MIRO Industries plant.
2. **Design Emphasis:** The 10DS, or "H" type, support is a versatile, custom product designed to support single or stacked duct, cable trays, or other rooftop components, at varying heights and widths with onsite vertical adjustability for maximum efficiency and cost savings to customers, contractors, and owners. The frame structure consists of at least two load-distributing bases with vertical strut legs and a horizontal strut header. Supports sizes are to be determined for project specific requirements and allow for a range of vertical adjustability. Horizontal cross-bracing between adjacent frames may be required.
3. **Manufacturer:** MIRO INDUSTRIES, INC.  
844 South 430 West, Suite 100,  
Heber City, Utah 84032  
Phone: (800) 768-6978  
Fax: (800) 440-7958
4. **Product Description:** A frame constructed of strut and MIRO's patented bases are used to support duct or various utilities on roofs with slopes up to 2 vertical units and 12 horizontal units or up to a 9-1/2 degree slope. Each support has a minimum of 2 bases made of polycarbonate plastic. All other parts are hot-dip galvanized or stainless-steel.
5. **Product Performance:** The frame system serves to keep the duct, or various utility system, directly over the frame without binding and allows for some lateral expansion of the supported system. The base is gently rounded to prevent gouging. Drainage ports are provided to prevent ponding within the device.
6. **Compatibility:** MIRO Custom 10DS supports are recommended for use on, and are compatible to use with, all current types of decking and with all commonly used built-up and single-ply roofing membranes where roof-mounted utilities occur. With heavier loads, it is prudent to use a MIRO Support Pad or other traffic pad to further protect the roof membrane.
7. **Loading/Design Constraints:** The 10DS series support is built to ensure member and component capacities and deflection criteria are not exceeded. Maximum loading from any MIRO base to the finished roof surface is not to exceed 3.0 psi unless specifically stated in the project specifications. Deflection in the horizontal header bar is not to exceed the span length divided by 360 or 1/8".
8. **Composition and Materials:** The 10DS support consists of two major components: (1) a minimum of two polycarbonate plastic (P) bases which sit on the roof membrane and (2) a hot-dip galvanized or stainless-steel strut frame assembly which is supported by, rests upon and is connected to the two bases.
9. **Size:** The series 10DS is made as follows: Each of the deck bases are 19 x 23 inch with 1-5/8 x 1-5/8 inch strut legs and a 1-5/8 inch header bar. The header bar may be 7/8, 1-5/8 or 3-1/4 inches tall as required for loading. The header bar will have a minimum length of 24 inches to accommodate the bases. The strut frame assembly is constructed to allow vertical adjustment of the header bar within a specified range.
10. **Adjustable Height:** The 10DS support allows for height adjustments as desired or required by the code or roof system. Cross-bracing two adjacent supports is required for elevations 36" and higher. Purchasers must specify desired heights and multiple duct configuration upon quote requests and ordering of 10DS series stands.
11. **Installation Process:** (1) Center the support directly below the location of the component to be supported. (2) Adjust the header bar to the desired height to maintain even-load distribution among the other stands. Make certain the header bar is level. (3) Set the components to be supported onto the frame without dropping or causing any undue impact.  

MIRO recommends an additional sheet of roofing material, or a MIRO Support Pad be installed beneath each base. For built up roofs, remove all loose aggregate from an area 2 inches larger in width and length than the base or support pad and follow the installation directions outlined above.
12. **Spacing:** Manufacturer's recommended spacing is not to exceed 8-foot centers depending upon the load. Make certain each pipestand is properly elevated and loading is distributed evenly to all pipestands. Support spacing is not to exceed the maximum spacing required in the component specifications, where applicable.
13. **Availability:** 10DS Supports are marketed throughout the United States through representatives and distributors.
14. **Maintenance:** Normal maintenance is not required. Semi-annual inspection is required to check frame position and set component alignment, check proper weight distribution, and to correct improper installation which may cause pipestand damage or failure.
15. **Technical Services:** Please call MIRO INDUSTRIES, INC: (800) 768-6978 or visit our website [www.miroind.com](http://www.miroind.com) for technical information and for graphic and CAD drawing downloads.

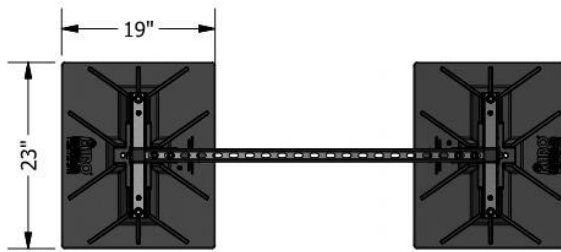

**Top View**



19x23 SUPPORT PAD  
\*ACCESSORY ITEM\*

**Isometric View**

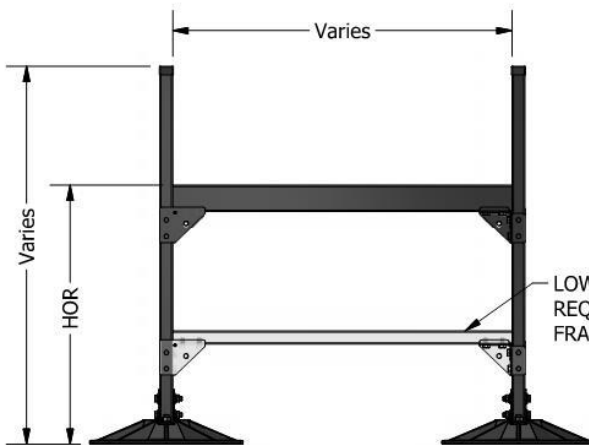

**Front View**

LOWER BRACE MAY BE  
REQUIRED ON TALLER  
FRAMES



**Side View**

**ACCESSORIES**

- 19 x 23 Support pad
- Cross bracing

**PRODUCT DESCRIPTION**

Duct and Cable Trays are designed for single or multiple duct supports and cable trays. To obtain pricing for the 10DS model, call your local representative and have the following information available:

1. Specify number of supports needed or provide a roof top duct layout drawing and MIRO Ind. will provide a support layout drawing and take off.
2. Dimensions of duct (Width x Height or Diam)
3. Duct material (gauge thickness)
4. Clearance height above roof (HOR)
5. Exterior insulation thickness (if any)
6. Does duct need to be endosed?

**KEY INFORMATION**

- The 10DS series support is engineered to ensure member/component capacities and deflection criteria are not exceeded.
- Maximum loading from any MIRO base to the finished roof surface is not to exceed 3.0 psi (960 psi/base) unless specifically allowed otherwise in the project specifications.
- Deflection in the horizontal header bar is not to exceed the span length by 360 or 1/8".
- Frame is designed for gravity loading only.
- Recommended spacing is not to exceed 8 feet centers depending upon the load.
- Width and height are built job specific based on information provided to MIRO Ind. with a minimum height of 12"
- Frame is made with 12 ga strut; size is determined during design.
- Base Material: Polycarbonate
- All metal parts are hot dip galvanized

The information contained in this drawing is the sole property of MIRO Industries, Inc. Any reproduction in part or as a whole without written permission of MIRO Industries, Inc. is prohibited.	DATE:	10DS P
	JAN 2019	

## GENERAL INSTALLATION OF CUSTOM HANGER AND DUCT SUPPORT MODELS

- 1) Frame structure is shipped assembled (unless otherwise noted) with two or more legs with the horizontal header bar and hangers positioned according to the layouts provided to MIRO Industries. The horizontal header bar is connected to the legs via a bolted connection using two or more gusset flanges. Hangers are attached to the frame at the approximate final height of the pipe to be supported.
- 2) The bases are not attached to the frame system for convenience and ease of shipping. The bases are shipped separately with the appropriate hardware to connect the base to the leg.
- 3) Insert the legs of the frame structure into the base assembly and install bolt hardware provided. Torque each bolted connection to 8 foot-pounds for correct tightness.
- 4) Clear all gravel and loose aggregate from an area 2 inches larger in width and length than the base or support pad.
- 5) Install a MIRO Support Pad or an appropriate roof pad. Pad must be compatible with the roof system and comply with all MIRO and roof manufacturer loading and other requirements.
- 6) Position bases on the support pad.
- 7) Make sure to adjust hanger frame heights to create positive and equal loading on each support.
- 8) After installation is complete, check all bases to see that each base rests firmly on the roof. Inspect again three months later and every six months thereafter.

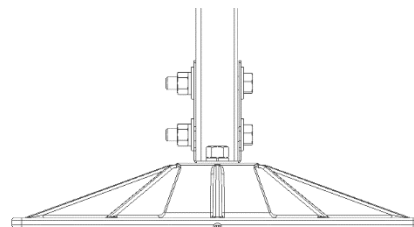
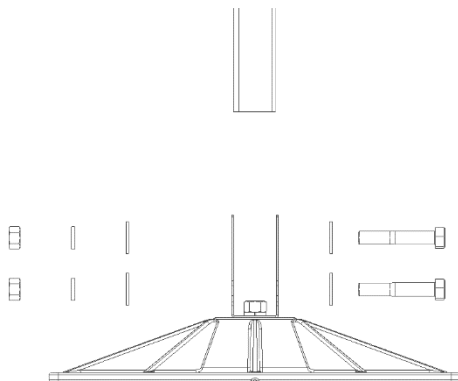
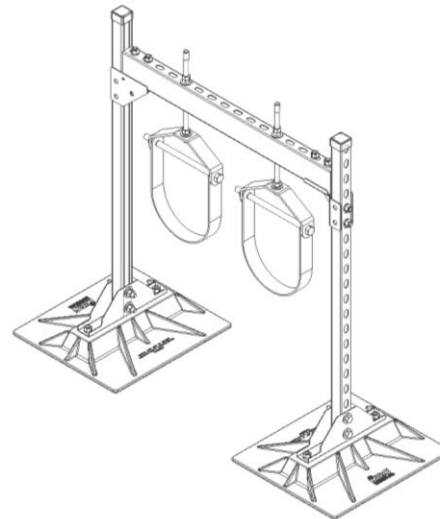
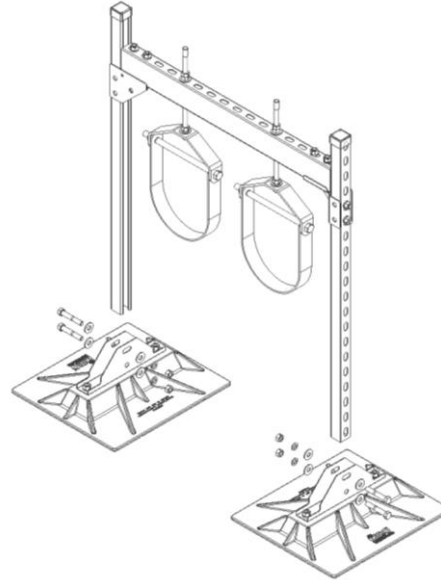

## INSTALACIÓN GENERAL DE LA PERCHA PERSONALIZADA Y MODELOS DE DE CONDUCTOS

- 1) Estructura del bastidor se envía montado (a menos que se indique lo contrario) con dos o más patas y con la barra de cabecera horizontal y colgadores colocados de acuerdo con las disposiciones proporcionadas dado a MIRO Industries. La barra de cabecera horizontal se conecta a las patas mediante una conexión atornillada utilizando dos o más bridas de refuerzo. Los colgadores se sujetan al bastidor a la altura aproximada de remate de la tubería que se va a apoyar.
- 2) Las bases no están conectadas al sistema del bastidor para mayor comodidad y facilidad de envío. Las bases se envían por separado con el hardware apropiado para conectar la base a la pata.
- 3) Inserte las patas de la estructura del bastidor en el ensamblaje de la base e instale el perno previsto. Apriete cada conexión atornillada a 8 libras por pie para una correcta estanqueidad.
- 4) Quite toda la grava y el agregado suelto de un área de 2 pulgadas más grande en anchura y longitud que la base o la almohadilla de apoyo.
- 5) Instale una almohadilla de soporte MIRO o una almohadilla de techo apropiada. La almohadilla debe ser compatible con el sistema de techo y cumpla con todos los requisitos de carga del fabricante MIRO y techo.
- 6) Coloque las bases en la almohadilla de soporte.
- 7) Asegúrese de ajustar las alturas del bastidor de suspensión para crear una carga positiva e igual en cada soporte.
- 8) Cuando la instalación esta finalizada, revise todas las bases para ver que cada base descansa firmemente en el techo. Vuelva a inspeccionar tres meses después y cada seis meses después.

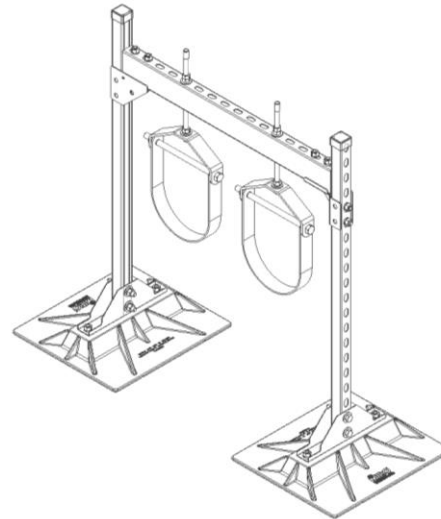
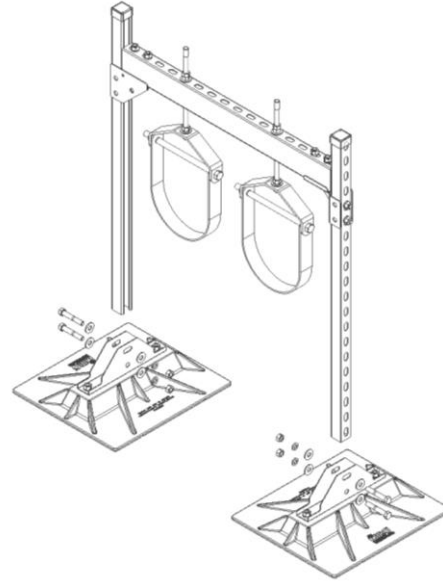



## CUSTOM SUPPORT SLOPE AND ADJUSTMENT

MIRO Industries Custom Series Supports are not only adjustable in height but can also be adjusted to accommodate different roof slope directions. On the 8H/8DS and 10H/10DS supports, the leg of the support can be rotated 90 degrees, allowing the base to pivot in one of two different directions. This allows the supports to accommodate pipe or duct that's running either parallel or perpendicular to the roof slope.

The adjustment of the base can accommodate up to a 2:12 (9.46 degree) slope. Contact MIRO Industries for support options that will work with a steeper slope.



OR





## **MECHANICAL SUPPORTS**

MIRO Mechanical Supports are a quick and easy solution to elevating rooftop mechanical units of all sizes. They are available in 2 varieties; LD, built for smaller and lighter rooftop equipment, and HD, which are custom-built for larger and heavier mechanical units of any size.

All Models are easily adjustable on site.

### **LD MECHANICAL UNIT SUPPORT**

MIRO LD Mechanical Supports are used to elevate small and light rooftop mechanical units. They are designed to support a unit 8" off the roof with a weight capacity of up to 200 lbs. They are available in several different dimensions to accommodate varying sized units. They may ship partially disassembled.

### **HD MECHANICAL UNIT SUPPORT**

The HD Mechanical Support is a larger alternative to the LD, providing increased adjustability, customization, and weight capacity. To obtain pricing for the HD Mechanical Support, please fill out our [Custom Quote Template](#) and submit it to your local Sales Representative.

## Product Data Sheet

# LD MECHANICAL UNIT SUPPORTS

1. **Product Name:** MIRO LD MECHANICAL UNIT SUPPORTS
2. **Manufacturer:** MIRO INDUSTRIES, INC.  
844 South 430 West, Suite 100,  
Heber City, Utah 84032  
Phone: (800) 768-6978  
Fax: (800) 440-7958
3. **Product Description:** LD Mechanical Unit Supports elevate rooftop mechanical units, such as air conditioning or other devices, to desired heights above the roof. LD Mechanical Unit Supports are designed so that the mechanical units rest in perforated metal pan that is elevated on all-thread fixed to four polycarbonate bases. The pan of the LD Mechanical Unit Supports can be adjusted from the factory-set maximum height of 8 inches down to a minimum height of 2-1/2 inches on the vertical all-thread. All metal pieces are made of hot-dip galvanized steel or stainless-steel for outdoor weathering protection. LD Mechanical Unit Supports consists of (1) a MIRO designed base with gently curved edges to protect the roof membrane and to distribute the weight over the maximum roof surface, (2) stainless-steel 3/8 inch all-thread and hot-dip galvanized hardware, and (3) a hot-dip galvanized perforated pan to support the mechanical unit.
4. **Product Performance:** LD Mechanical Unit Supports can be used to support mechanical devices which are positioned upon the roof. LD Mechanical Supports are typically set on the roof surface as a free-floating system. As units operate and as daytime temperatures warm and cool in the rooftop environment, mechanical equipment and connected piping expands and contracts with the temperature fluctuations. LD Mechanical Unit Supports are designed to support such devices and absorb such movement in a way that protects the roof. Vibration eliminators can be added to units, if necessary. Free-floating support systems may not meet code requirements for other applicable lateral loading.
5. **Compatibility:** LD Mechanical Unit Supports are recommended for use on, and are compatible with, all current types of decking and with all commonly used built-up and single-ply roofing membranes where roof-mounted mechanical equipment is installed.
6. **Load Weight:** Maximum load weight is equivalent to, and is part of, the maximum rooftop bearing-load which MIRO has designed for its bases. MIRO recommends such loading not exceed 200 pounds to any of the LD Mechanical Unit Supports.
7. **Composition and Materials:** LD Mechanical Unit Supports are made with either polycarbonate, hot-dip galvanized or stainless-steel bases, stainless-steel all-thread with hot-dip galvanized hardware and a 11 gauge hot-dip galvanized perforated pan.
8. **Size:** LD Mechanical Unit Supports are manufactured to adjust in height from the factory-set maximum of 8 inches down to a minimum of 2-1/2 inches. Each base must be adjusted so that the pan sits level and the bases sit flat on the roof surface. LD Mechanical Unit Supports pan sizes are available in 24 x 24 inch, 30 x 30 inch, 20 x 36 inch, and 36 x 36 inch sizes. Custom sizes can be provided upon request.
9. **Installation:** (1) Determine the dimension and location so the supported unit will rest upon the roof at the desired height, (2) place the LD Mechanical Unit Supports in the approximate positions so as to allow the mechanical unit or device to fit down in and upon the metal pan, (3) take final measurements and adjust the Mechanical Unit Support to fit properly allowing the load to be distributed evenly to the feet of the support. Care should be taken to adjust each LD Mechanical Unit Support to make sure equal weight, or an equal load, is resting upon each base and the bases are sitting firmly on the deck.  
  
MIRO recommends an additional sheet of roofing material, or a MIRO Support Pad be installed beneath each base. For built up roofs, remove all loose aggregate from an area 2 inches larger in width and length than the base or support pad and follow the installation directions outlined above.
10. **Spacing:** LD Mechanical Unit Support should be spaced at intervals to allow proper installation of the mechanical units or devices, and to not exceed recommended weight bearing upon rooftop materials which MIRO recommends not to exceed 3.0 lbs. per square inch.
11. **Availability:** LD Mechanical Unit Supports are marketed throughout the United States through representatives and distributors.
12. **Maintenance:** Normal maintenance is not required. Semi-annual inspection is required to check support position, pipe alignment, weight distribution, and to correct improper installation which may cause system failure or damage.
13. **Technical Services:** Please call MIRO INDUSTRIES, INC: (800) 768-6978 or visit our website [www.miroind.com](http://www.miroind.com) for technical information and for graphic and CAD drawing downloads.

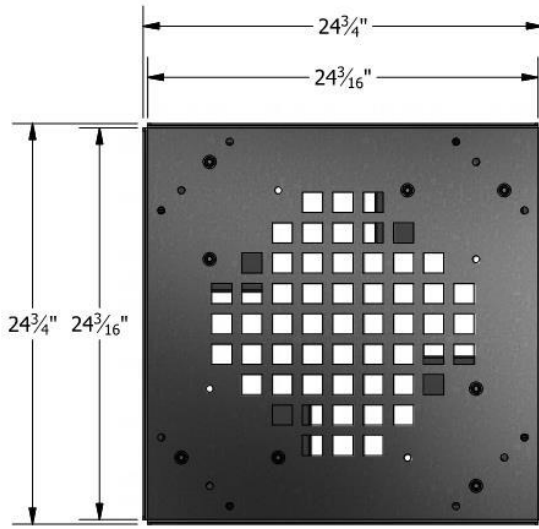

**TOP VIEW**

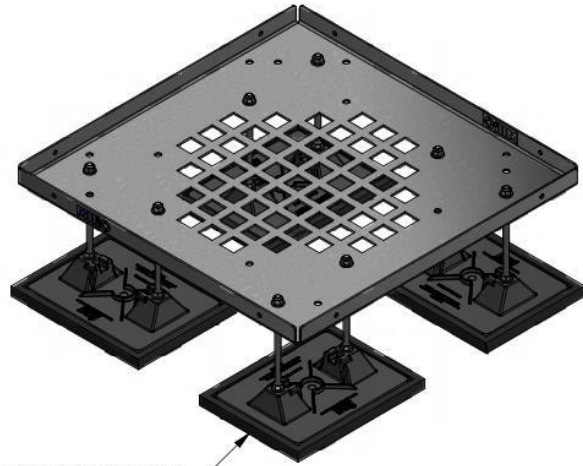

**ISOMETRIC**

7 1/2" x 10" SUPPORT PAD  
\*ACCESSORY ITEM\*



**SIDE VIEW**

1 7/8"  
8" MAX  
2 1/2" MIN

**ACCESSORIES**

- 7 1/2" x 10" Support pad
- Eternabond® 2-sided tape

**PRODUCT DESCRIPTION**

The MIRO LD-Mechanical Supports are designed to elevate rooftop mechanical units, cabinets and other devices. The LD-Mechanical Support pan is designed with slots to allow proper ventilation as well as moisture drainage away from the unit. The supports are adjustable in height per the drawing.

**KEY INFORMATION**

- Designed to support mechanical units, cabinets and other devices.
- Adjustable height from the factory set maximum height of 8" down to a minimum of 2 1/2", even load required, maximum load is 200 lbs.
- Custom sizes available
- Base Material: Polycarbonate
- All metal parts are either stainless steel, hot-dip galvanized or pre-galvanized.

The information contained in this drawing is the sole property of MIRO Industries, Inc. Any reproduction in part or as a whole without written permission of MIRO Industries, Inc. is prohibited.	DATE:	LD 24x24x8
	JAN 2019	



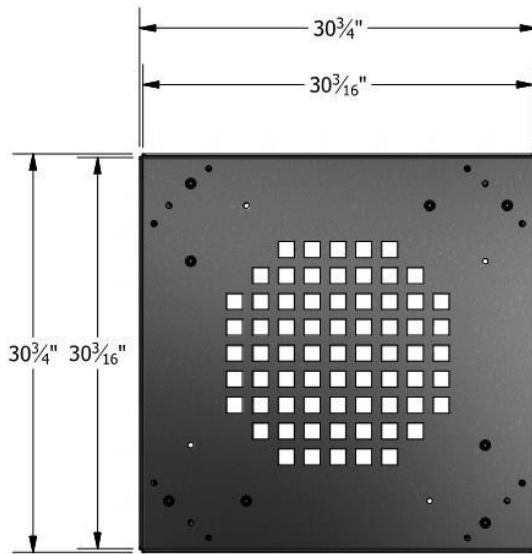

**TOP VIEW**

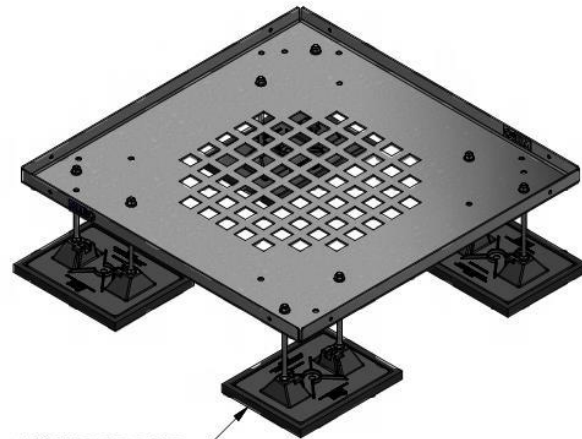

7 1/2" x 10" SUPPORT PAD  
\*ACCESSORY ITEM\*

**ISOMETRIC**

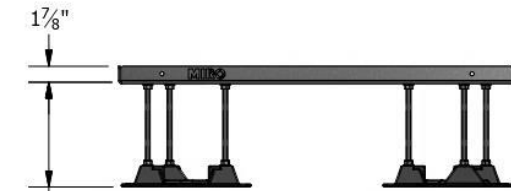

1 7/8"  
8" MAX  
2 1/2" MIN

**SIDE VIEW**

**ACCESSORIES**

- 7 1/2" x 10" Support pad
- Eternabond® 2-sided tape

**PRODUCT DESCRIPTION**

The MIRO LD-Mechanical Supports are designed to elevate rooftop mechanical units, cabinets and other devices. The LD-Mechanical Support pan is designed with slots to allow proper ventilation as well as moisture drainage away from the unit. The supports are adjustable in height per the drawing.

**KEY INFORMATION**

- Designed to support mechanical units, cabinets and other devices.
- Adjustable height from the factory set maximum height of 8" down to a minimum of 2 1/2", even load required, maximum load is 200 lbs.
- Custom sizes available
- Base Material: Polycarbonate
- All metal parts are either stainless steel, hot-dip galvanized or pre-galvanized.

The information contained in this drawing is the sole property of MIRO Industries, Inc. Any reproduction in part or as a whole without written permission of MIRO Industries, Inc. is prohibited.	DATE:	LD 30x30x8
	JAN 2019	

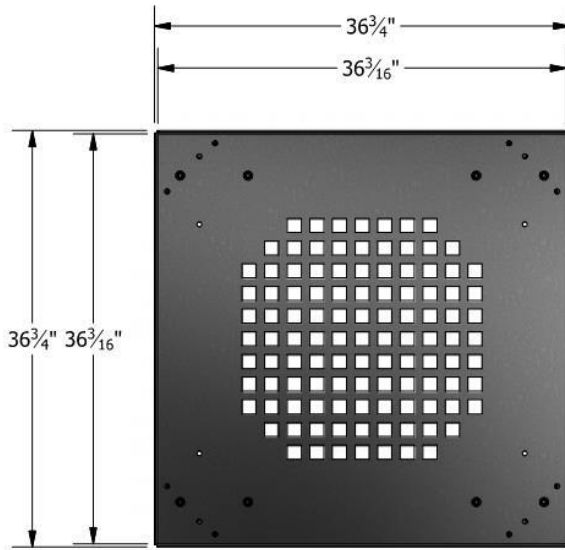

**TOP VIEW**

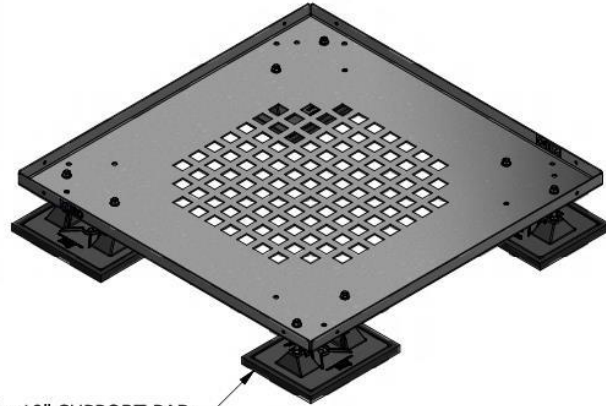

7 1/2" x 10" SUPPORT PAD  
\*ACCESSORY ITEM\*

**ISOMETRIC**

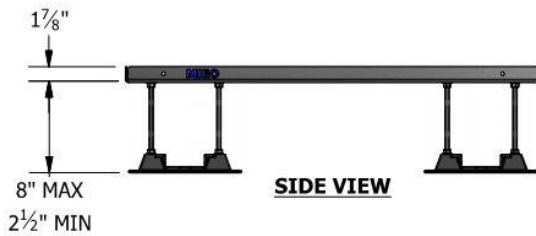

**SIDE VIEW**

**ACCESSORIES**

- 7 1/2" x 10" Support pad
- Eternabond® 2-sided tape

**PRODUCT DESCRIPTION**

The MIRO LD-Mechanical Supports are designed to elevate rooftop mechanical units, cabinets and other devices. The LD-Mechanical Support pan is designed with slots to allow proper ventilation as well as moisture drainage away from the unit. The supports are adjustable in height per the drawing.

**KEY INFORMATION**

- Designed to support mechanical units, cabinets and other devices.
- Adjustable height from the factory set maximum height of 8" down to a minimum of 2 1/2", even load required, maximum load is 200 lbs.
- Custom sizes available
- Base Material: Polycarbonate
- All metal parts are either stainless steel, hot-dip galvanized or pre-galvanized.

The information contained in this drawing is the sole property of MIRO Industries, Inc. Any reproduction in part or as a whole without written permission of MIRO Industries, Inc. is prohibited.

DATE:  
JAN 2019

LD 36x36x8

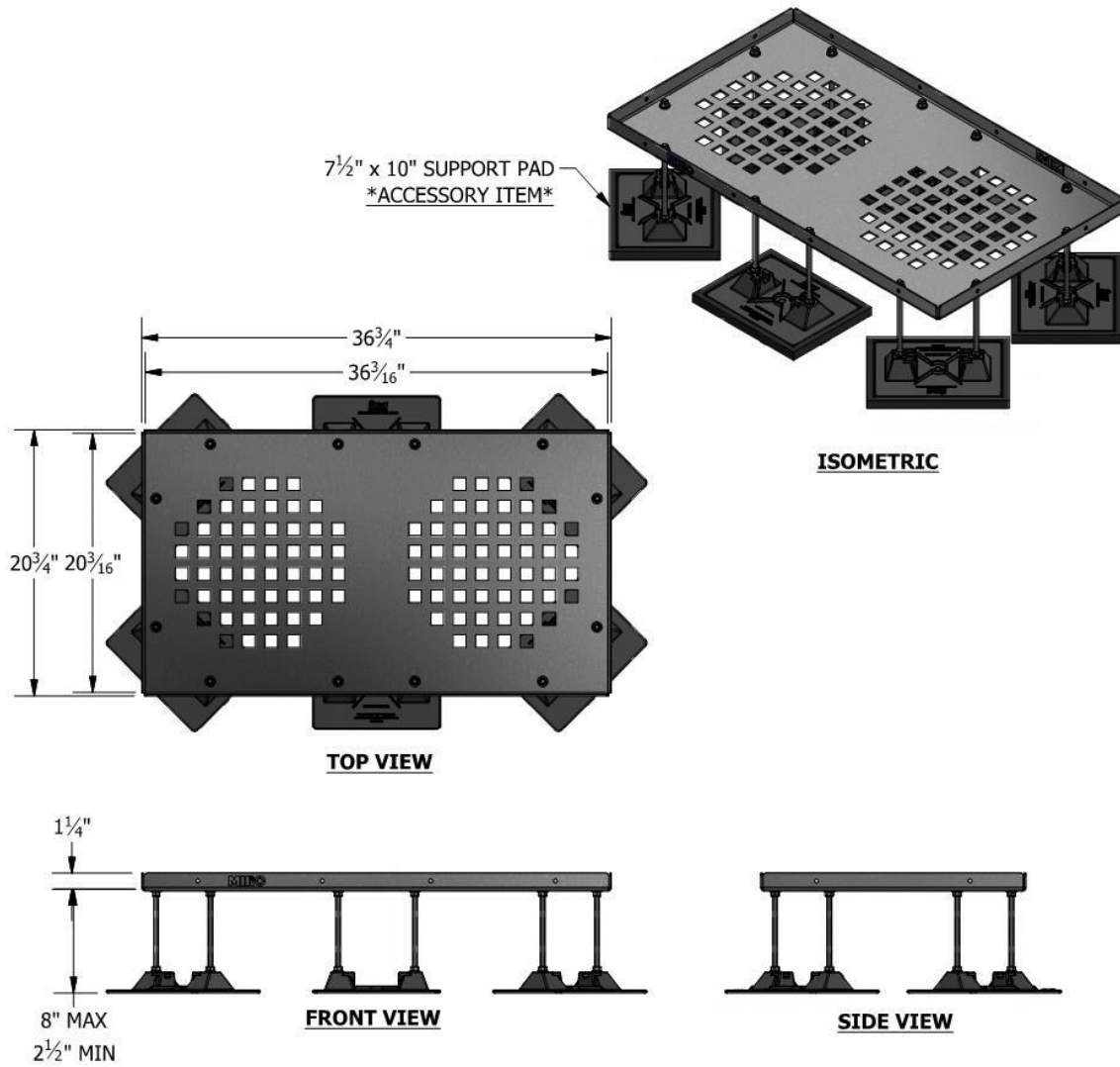

**ACCESSORIES**

- 7½" x 10" Support pad
- Eternabond® 2-sided tape

**PRODUCT DESCRIPTION**

The MIRO LD-Mechanical Supports are designed to elevate rooftop mechanical units, cabinets and other devices. The LD-Mechanical Support pan is designed with slots to allow proper ventilation as well as moisture drainage away from the unit. The supports are adjustable in height per the drawing.

**KEY INFORMATION**

- Designed to support mechanical units, cabinets and other devices.
- Adjustable height from the factory set maximum height of 8" down to a minimum of 2½", even load required, maximum load is 200 lbs.
- Custom sizes available
- Base Material: Polycarbonate
- All metal parts are either stainless steel, hot-dip galvanized or pre-galvanized.

The information contained in this drawing is the sole property of MIRO Industries, Inc. Any reproduction in part or as a whole without written permission of MIRO Industries, Inc. is prohibited.	DATE:	LD 20x36x8
	JAN 2019	

## Product Data Sheet

# HD MECHANICAL UNIT SUPPORTS

1. **Product Name:** HD MECHANICAL UNIT SUPPORTS
2. **Manufacturer:** MIRO INDUSTRIES, INC.  
844 South 430 West, Suite 100,  
Heber City, Utah 84032  
Phone: (800) 768-6978  
Fax: (800) 440-7958
3. **Product Description:** HD Mechanical Unit Supports elevate rooftop mechanical units, such as air conditioning or other devices, to desired heights above the roof. HD Mechanical Unit Supports are designed so that the mechanical units' rests on a level plane elevated above the roof surface. The system is designed to carry the weight of the unit and distribute the load to the roof surface through a frame system connected to either a polycarbonate, stainless-steel or hot-dip galvanized base. HD Mechanical Unit Supports are adjustable in the field via bolted connections so that a level surface at the desired height can be obtained. All metal parts are made of either hot-dip galvanized steel or stainless-steel for outdoor weathering protection. HD Mechanical Unit Supports consists of (1) a MIRO designed base, with gently curved edges to protect the roof membrane, that distributes the weight over the maximum roof surface (2) hot-dip galvanized steel strut or stainless-steel frame structure, and (3) galvanized planking, bar grading or a rail system that the mechanical unit rests on and can be attached to.
4. **Product Performance:** HD Mechanical Unit Supports can be used to support mechanical devices which are positioned upon the roof. HD Mechanical Supports are typically set on the roof surface as a free-floating system. As units operate and as daytime temperatures warm and cool in the rooftop environment, mechanical equipment and connected piping expands and contracts with the temperature fluctuations. HD Mechanical Unit Supports are designed to support such devices and absorb such movement in a way that protects the roof. Vibration eliminators can be added to units if necessary. Free floating support systems may not meet code requirements for other applicable lateral loading.
5. **Compatibility:** HD Mechanical Unit Supports are recommended for use on, and are compatible with, all current types of decking and with all commonly used built-up and single-ply roofing membranes where roof-mounted pipes and devices are installed.
6. **Load Weight:** Maximum load weight is equivalent to, and is part of, the maximum rooftop bearing-load, which shall be determined for each support based on the unit size and weight. MIRO recommends loading on HD Mechanical supports not exceed 3 lbs. per square inch to the roof surface under any of the support bases. In addition, a deflection limit for frame members shall not exceed the span length divided by 360 ( $L/360$ ) and a maximum recommended deflection not to exceed 1/8 inch.
7. **Composition and Materials:** HD Mechanical Unit Supports are made with either polycarbonate, hot-dip galvanized or stainless-steel bases and either hot-dip galvanized or stainless-steel framing and hardware. Base sizes are determined based on loading requirements for the support and load distribution to the roof.
8. **Size:** HD Mechanical Unit Supports are manufactured to project specific dimensions, and they are to have height adjustability to ensure a level surface and provide desired heights off the roof.
9. **Installation:** (1) Determine the dimensions, weight, desired height off the roof, and location of the unit on the roof, (2) place the HD Mechanical Unit Supports in their approximate positions, and level the support framing for the unit, ensuring each base sits flat on the roof surface, (3) take final measurements and adjust the Mechanical Unit Support to fit properly, allowing the load to be distributed throughout the framing system to ensure that an even amount of load (not to exceed 3.0 pounds per square inch) is placed upon each leg and base support, (4) and adjustment in height can be obtained by moving the framing system up and down the leg of the support through adjustment of the brackets.  
  
MIRO recommends an additional sheet of roofing material, or a MIRO Support Pad be installed beneath each base. For built up roofs, remove all loose aggregate from an area 2 inches larger in width and length than the base or support pad and follow the installation directions outlined above.
10. **Spacing:** Each HD Mechanical Unit Support should be spaced at intervals to allow proper installation of the mechanical units or devices, and so as not to exceed recommended weight bearing upon rooftop materials which MIRO recommends not to exceed 3.0 lbs. per square inch.
11. **Availability:** HD Mechanical Unit Supports are marketed throughout the United States through representatives and distributors.
12. **Maintenance:** Normal maintenance is not required. Semi-annual inspection is required to check support position, pipe alignment, weight distribution, and to correct improper installation which may cause system failure or damage.
13. **Technical Services:** Please call MIRO INDUSTRIES, INC: (800) 768-6978 or visit our website [www.miroind.com](http://www.miroind.com) for technical information and for graphic and CAD drawing downloads.



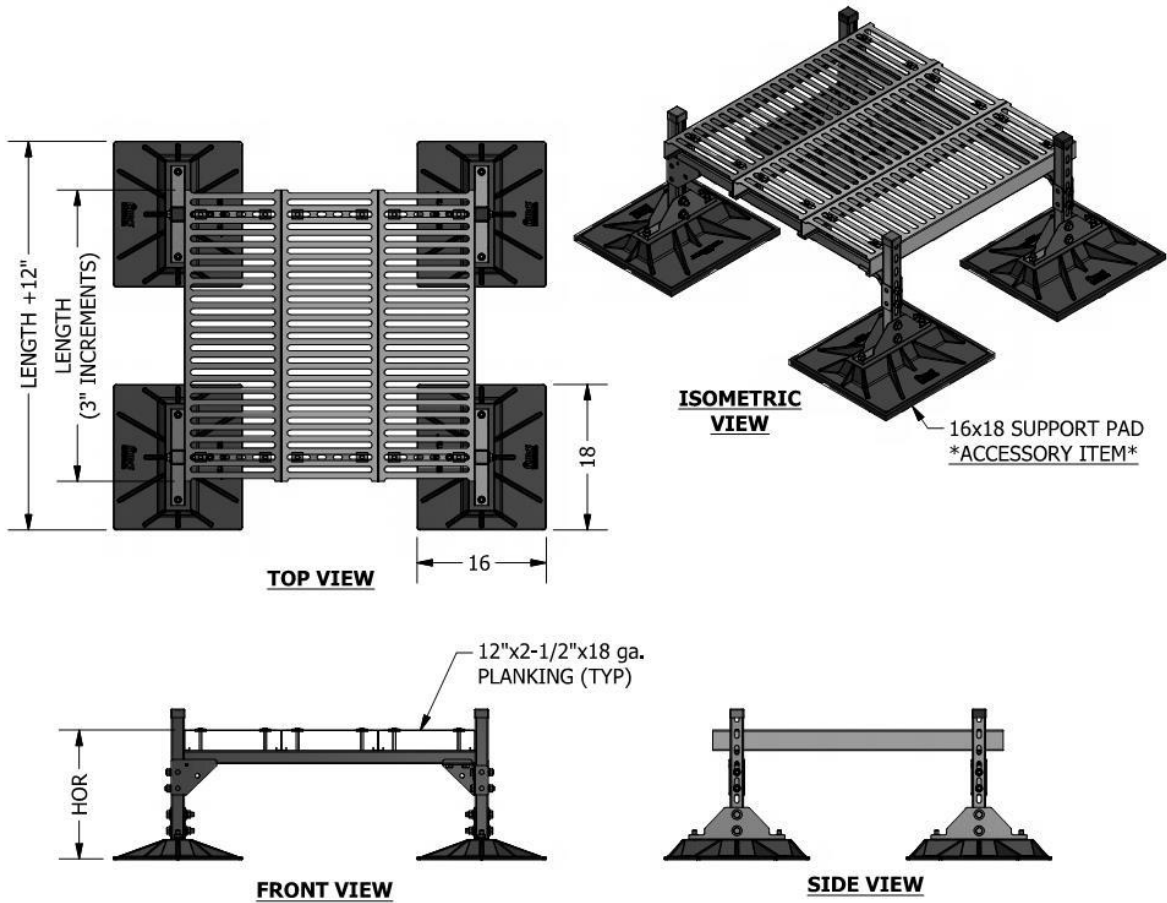

**ACCESSORIES**

- 16 x 18 Support pad
- Eternabond® 2-sided tape

**PRODUCT DESCRIPTION**

MIRO HD-Mechanical Supports are designed to elevate rooftop mechanical units, cabinets and other devices. The HD-Mechanical Support deck is 12" x 2-1/2" x 18 ga. planking. The supports are adjustable in height per the project requirements. All metal parts are hot-dip galvanized for outdoor weathering protection. The support bases are injection molded Polycarbonate.

**KEY INFORMATION**

- Designed to support mechanical units, cabinets and other devices.
- Designed to meet project specific dimensions with adjustability as specified.
- Support Deck is constructed of 12" x 2-1/2" x 18 ga. metal planking. (Bar Grating may be specified or required depending on loading and dimensional requirements)
- Support is designed to not exceed 3.0 psi to the finished roof surface under each base.
- Base Material: Polycarbonate
- All metal parts are either stainless steel, hot-dip galvanized or pre-galvanized.
- Non-Anchored supports do not provide significant resistance to wind or seismic loading. Contact MIRO Industries for wind and seismic solutions.
- Manufacturer suggested loading is not to exceed 550 lbs to each base. Contractor to ensure load distribution to each base does not exceed suggested loading to each base.

<p>The information contained in this drawing is the sole property of MIRO Industries, Inc. Any reproduction in part or as a whole without written permission of MIRO Industries, Inc. is prohibited.</p>	<p>DATE: JAN 2019</p>	<p>8-HD(P) Mechanical Support</p>
--	---------------------------	-----------------------------------

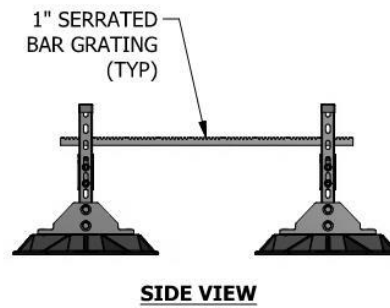
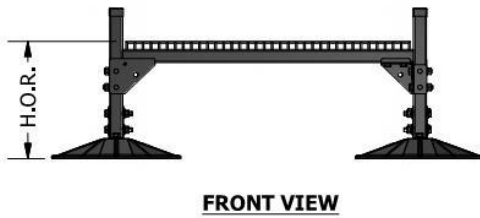
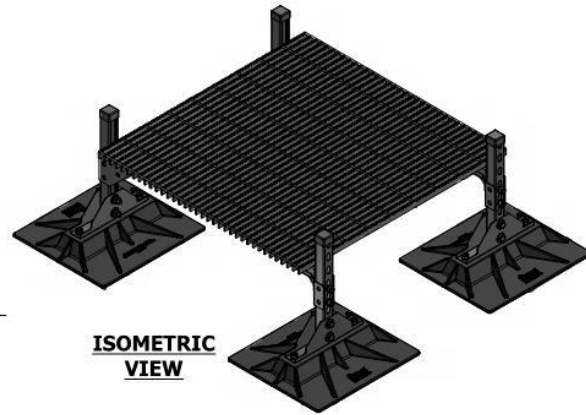
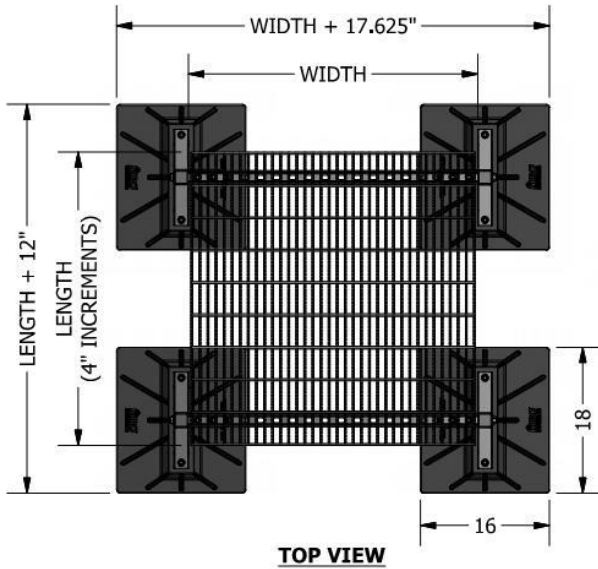

#### **ACCESSORIES**

- 16 x 18 Support pad
- Eternabond® 2-sided tape

#### **PRODUCT DESCRIPTION**

MIRO HD-Mechanical Supports are designed to elevate rooftop mechanical units, cabinets and other devices. The HD-Mechanical Support deck is 1" non slip hot-dip galvanized bar grating unless otherwise required or specified.

The supports are adjustable in height per the project requirements.

All metal parts are hot-dip galvanized for outdoor weathering protection. The support bases are injection molded Polycarbonate.

#### **KEY INFORMATION**

- Designed to support mechanical units, cabinets and other devices.
- Designed to meet project specific dimensions with adjustability as specified.
- Support Deck is constructed of 1" HDG Bar Grating. (UNO)
- Support is designed to not exceed 3,0 psi to the finished roof surface under each base.
- Base Material: Polycarbonate
- All metal parts are either stainless steel, hot-dip galvanized or pre-galvanized.
- Non-Anchored supports do not provide significant resistance to wind or seismic loading. Contact MIRO Industries for wind and seismic solutions.
- Manufacturer suggested loading is not to exceed 550 lbs to each base. Contractor to ensure load distribution to each base does not exceed suggested loading to each base.

The information contained in this drawing is the sole property of MIRO Industries, Inc. Any reproduction in part or as a whole without written permission of MIRO Industries, Inc. is prohibited.

DATE:  
JAN 2019

8-HD(BG) Mechanical Support

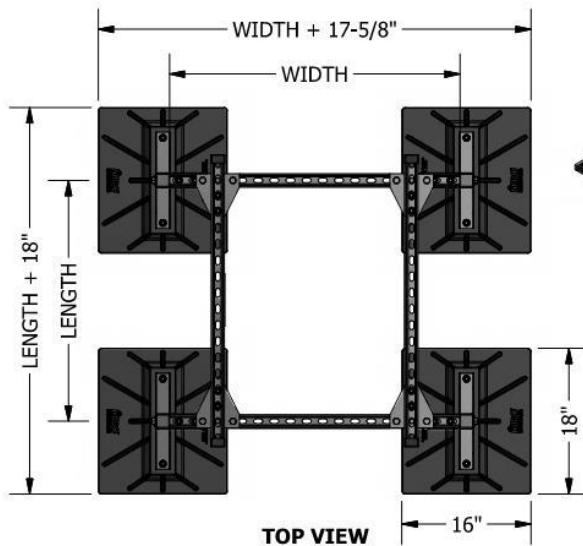

**TOP VIEW**

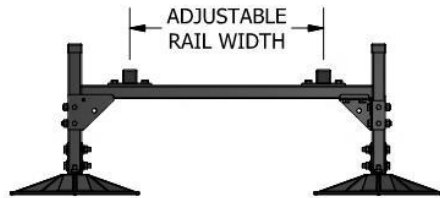

**FRONT VIEW**

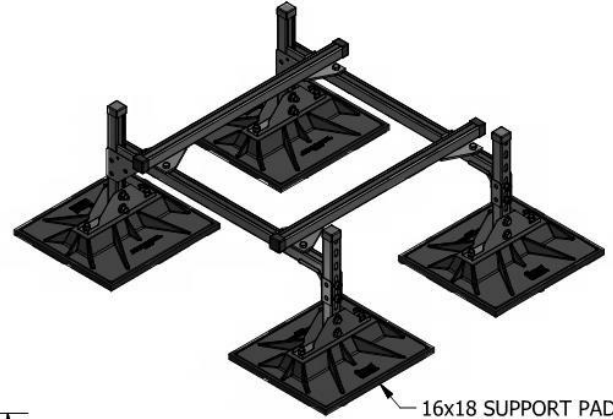

**ISOMETRIC VIEW**

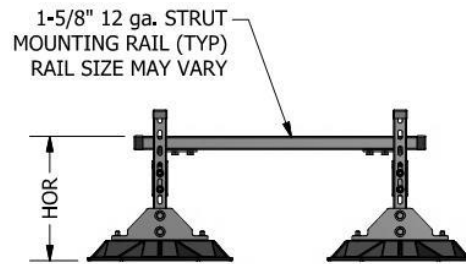

**SIDE VIEW**

**ACCESSORIES**

- 16 x 18 Support pad
- Eternabond® 2-sided tape

**PRODUCT DESCRIPTION**

MIRO HD-Mechanical Supports are designed to elevate rooftop mechanical units, cabinets and other devices. The HD-Mechanical Support has (2) 1-5/8" 12 ga. strut rails for mounting the equipment to. The supports are adjustable in height per the project requirements. All metal parts are hot-dip galvanized for outdoor weathering protection. The support bases are injection molded Polycarbonate.

**KEY INFORMATION**

- Designed to support mechanical units, cabinets and other devices.
- Designed to meet project specific dimensions with adjustability as specified.
- 1-5/8" 12 ga. strut rails for anchoring equipment to the support. Capacity of rail to be verified based on unit weight.
- Support is designed to not exceed 3.0 psi to the finished roof surface under each base.
- Base Material: Polycarbonate
- All metal parts are either stainless steel, hot-dip galvanized or pre-galvanized.
- Non-Anchored supports do not provide significant resistance to wind or seismic loading. Contact MIRO Industries for wind and seismic solutions.
- Manufacturer suggested loading is not to exceed 550 lbs to each base. Contractor to ensure load distribution to each base does not exceed suggested loading to each base.

The information contained in this drawing is the sole property of MIRO Industries, Inc. Any reproduction in part or as a whole without written permission of MIRO Industries, Inc. is prohibited.	DATE:	8-HD(R) Mechanical Support
	JAN 2019	





## **SUREFOOT ACCESS**

Built to offer safe and cost-effective access to facilities and equipment, Surefoot Access products are custom-designed to meet your site and OSHA standards. They are shipped partially assembled and ready for easy on-site assembly.

- Surefoot Bridge Crossovers span across pipes, ducts, expansion joints, elevation changes and other potential obstructions with engineered stair access.
- Surefoot Ramps provide solutions for wheeled access to areas previously blocked by rooftop pipes, structural gaps, or minor elevation changes, allowing heavy items to be rolled in or out for placement or service.
- Surefoot Service Platforms offer secure, elevated access to equipment in almost any setting, and they are specifically designed for rooftop applications.

Molded polycarbonate bases effectively distribute weight to prevent point loading, damage to the roof surface or other critical rooftop equipment. Slip-resistant bar grating, or interlock planking, are used on all walking surfaces to ensure solid footing and minimize snow and ice accumulation. In high wind or seismic zones, MIRO can engineer structural anchor points to maintain code and safety compliance. To resist corrosion, all Surefoot Access products are made of 100% galvanized materials.



## Product Data Sheet

# SUREFOOT ACCESS BRIDGE CROSSOVERS

1. **Product Name:** SUREFOOT ACCESS BRIDGE CROSSOVERS
2. **Manufacturer:** MIRO INDUSTRIES, INC.  
844 South 430 West, Suite 100,  
Heber City, Utah 84032  
Phone: (800) 768-6978  
Fax: (800) 440-7958
3. **Product Description:** Surefoot Access Bridge Crossovers provide a safe and cost-effective means to access rooftop equipment. Surefoot Access Bridge Crossovers are custom-designed to meet OSHA and building code standards for limited access applications. Bridge Crossovers can span across pipes, ducts, expansion joints, elevation changes and other potential obstructions. Bridge crossovers are typically designed to OSHA standards for standard stairways as recommended in OSHA 1910.25(b)(8). Where not feasible, an alternate method such as ship ladders or vertical ladders can also be provided where a standard stair will not work. Each crossover section is designed to carry applicable loading, per OSHA requirements, and distribute the loading to the roof surface through the frame system connected to either a polycarbonate, stainless-steel or hot-dip galvanized base. Each Access Bridge Crossover is adjustable in the field via bolted connections to accommodate roof and height variations. All metal parts are made from either hot-dip galvanized steel or stainless-steel for outdoor weathering protection. Surefoot Access Bridge Crossovers consists of (1) a MIRO designed base, with gently curved edges to protect the roof membrane that effectively distributes the weight over the maximum roof surface, (2) hot-dip galvanized steel strut or stainless-steel frame structure, and (3) galvanized planking, or bar grating with an anti-slip surface for walking on.
4. **Product Performance:** Surefoot Access Bridge Crossovers provide a means to safely access rooftop equipment around physical obstacles. Bridge Crossovers are typically set on the roof surface as a free-floating system, but positive attachment of the system to the building structure may be required for code compliance. Where required, a means for positive attachment to the building structure can be provided and coordinated by MIRO Industries.
5. **Compatibility:** Surefoot Access Bridge Crossover units are recommended for use on, and are compatible with, all current types of decking and with all commonly used built-up and single-ply roofing membranes, where access across physical obstacles on a rooftop is required.
6. **Load Weight:** Maximum load weight is equivalent to and is part of the maximum rooftop bearing load, which shall be determined for each crossover based on dimensions and the weight of the system. MIRO recommends loading not exceed 3 lbs. per square inch from each base to the roof surface. In addition, a deflection limit for frame members shall not exceed the span length divided by 360 ( $L/360$ ) and a maximum recommended deflection not to exceed 1/8 inch.
7. **Composition and Materials:** Bridge Crossovers are made with either polycarbonate, hot-dip galvanized or stainless-steel bases and either hot-dip galvanized or stainless-steel framing and hardware with a non-slip plank or bar-grating as the walking surface. Base sizes are determined based on loading requirements for the support and load distribution to the roof.
8. **Size:** Surefoot Access Bridge Crossovers are manufactured to project-specific dimensions and are to have limited-height adjustability to ensure a level surface and desired heights off the roof are achievable.
9. **Installation:** (1) Determine the required dimensions of the system including width, clearance height from the roof surface to the lowest point of the bridge section, and the location of the unit on the roof, (2) assemble the Bridge Crossover in the approximate location and adjust the support, as needed, to ensure each base rest firmly on the roof surface.  
  
MIRO recommends an additional sheet of roofing material, or a MIRO Support Pad be installed beneath each base. For built up roofs, remove all loose aggregate from an area 2 inches larger in width and length than the base or support pad and follow the installation directions outlined above.
10. **Spacing:** Surefoot Access Bridge Crossovers are built to standards established in OSHA 1910 Subpart D for Walking-Working Surfaces. Contractors are to ensure clearances above and around crossovers are provided in accordance with OSHA Standards.
11. **Availability:** Surefoot Access Crossover Bridges are marketed throughout the United States through representatives and distributors.
12. **Maintenance:** Normal maintenance is not required. Semi-annual inspection is required to check crossover position, and to ensure no hazardous conditions exists on or around the system.
13. **Technical Services:** Please call MIRO INDUSTRIES, INC: (800) 768-6978 or visit our website [www.miroind.com](http://www.miroind.com) for technical information and for graphic and CAD drawing downloads.

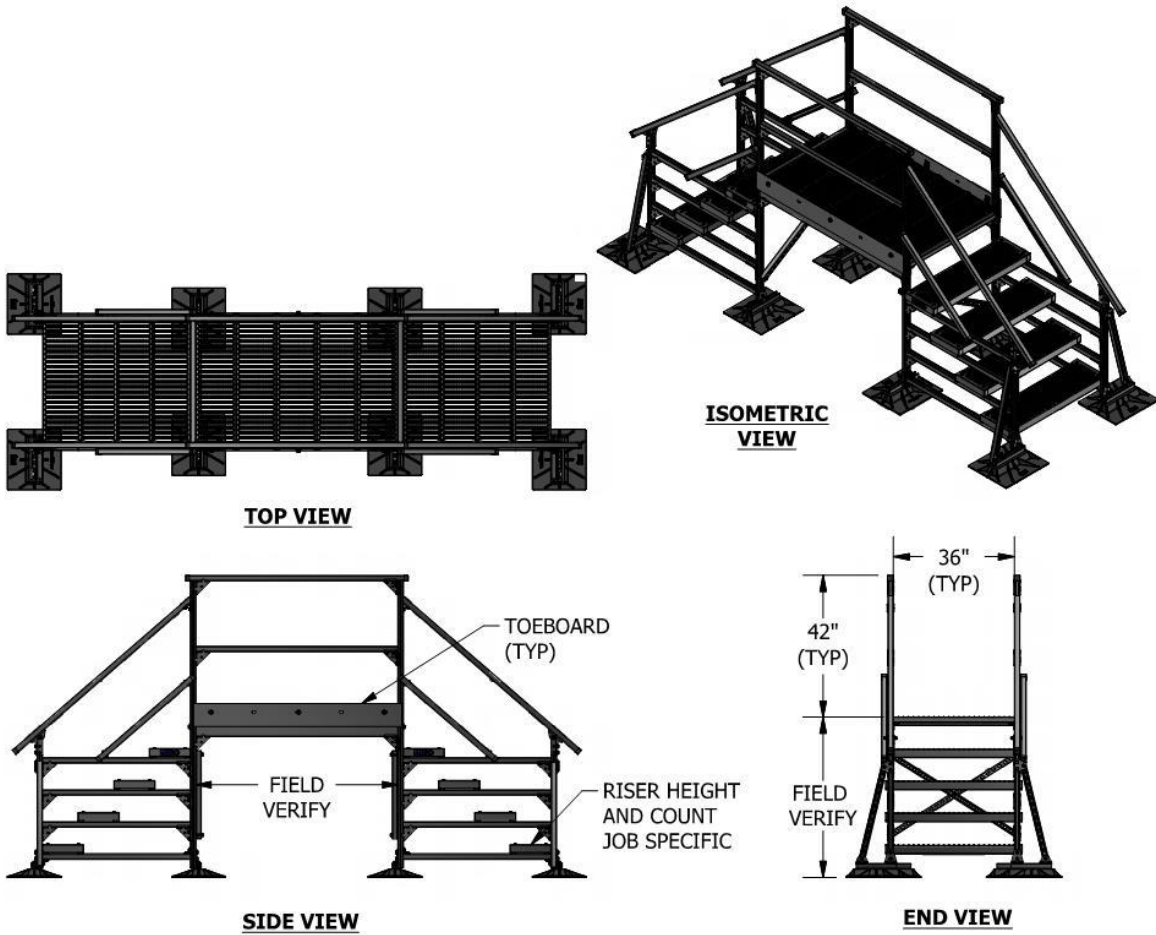

**ACCESSORIES**

- MIRO Support pad
- Eternabond® 2-sided tape

**PRODUCT DESCRIPTION**

The MIRO Surefoot Step Bridge Crossover is constructed of 1-5/8" 12 ga. strut framing and 12" non-slip planking. 16"x18" polycarbonate bases ensure proper load distribution to your roof deck.

MIRO crossover structures are designed to meet OSHA 1910 Subpart D requirements for walking/working surfaces. Anchorage of the crossover to the building structure may be required for applicable lateral and uplift loading.

**INSTALLATION PROCEDURES**

1. Typical MIRO Surefoot bridge crossover, walkway, service platform and ramp systems are shipped partially assembled. (Field assembly is required)
2. Use provided hardware and included drawings to build a suitable support.
3. Clear all loose gravel and aggregate away from base locations.
4. Place MIRO base on a MIRO Support Pad or other sacrificial pad for additional protection.
5. Make sure each base is firmly resting on the roof surface, making any necessary adjustments so that even-loading is distributed to the roof.

**CUSTOM SIZES AND LAYOUTS CAN BE DESIGNED TO MEET YOUR PROJECT REQUIREMENTS.**

<p>The information contained in this drawing is the sole property of MIRO Industries, Inc. Any reproduction in part or as a whole without written permission of MIRO Industries, Inc. is prohibited.</p>	<p>DATE: JAN 2019</p>	<p>BRIDGE CROSSOVER</p>
--	---------------------------	-------------------------

## Product Data Sheet

# SUREFOOT ACCESS SERVICE PLATFORMS

1. **Product Name:** SUREFOOT ACCESS SERVICE PLATFORMS
2. **Manufacturer:** MIRO INDUSTRIES, INC.  
844 South 430 West, Suite 100,  
Heber City, Utah 84032  
Phone: (800) 768-6978  
Fax: (800) 440-7958
3. **Product Description:** Surefoot Access Service Platforms provide a safe and cost-effective means to access and maintain rooftop equipment. Surefoot Access Service Platforms are custom-designed to meet OSHA and building code standards for limited access applications. Service Platforms can be designed to fit around most any rooftop unit where maintenance personnel need a level and safe working service to perform their tasks, without requiring the use of a portable ladder. Access to Surefoot Access Service Platforms is typically designed to OSHA standards for standard stairways as recommended in OSHA 1910.25(b)(8). Where not feasible, an alternate method such as ship ladder or vertical ladder can also be provided where a standard stair will not work. Each service platform is designed to carry applicable loading per OSHA requirements and distribute the loading to the roof surface through the frame system connected to either a polycarbonate, stainless-steel or hot-dip galvanized base. Each Service Platform is adjustable in the field via bolted connections to accommodate roof and height variations. All metal parts are made from either hot-dip galvanized steel or stainless-steel for outdoor weathering protection. Surefoot Access Service Platforms consists of (1) a MIRO designed base with gently curved edges to protect the roof membrane that effectively distributes the weight over the maximum roof surface, (2) hot-dip galvanized steel strut or stainless-steel frame structure, and (3) galvanized planking, or bar grading with an anti-slip surface for walking on.
4. **Product Performance:** Surefoot Access Service Platforms provide a means to safely access and maintain rooftop equipment. Service Platforms are typically set on the roof surface as a free-floating system, but positive attachment of the system to the building structure may be required for code compliance. Where required, a means for positive attachment to the building structure can be provided and coordinated by MIRO Industries.
5. **Compatibility:** Surefoot Access Service Platforms are recommended for use on and are compatible with all current types of decking and with all commonly used built-up and single-ply roofing membranes where accessing rooftop equipment for inspection or service is required.
6. **Load Weight:** Maximum load weight is equivalent to and is part of the maximum roof top bearing load, which shall be determined for each platform based on dimensions and the weight of the system. MIRO recommends loading not exceed 3 lbs. per square inch from each base to the roof surface. In addition, a deflection limit for frame members shall not exceed the span length divided by 360 ( $L/360$ ) and a maximum recommended deflection not to exceed 1/8 inch.
7. **Composition and Materials:** Service Platforms are made with either polycarbonate, hot-dip galvanized or stainless-steel bases and either hot-dip galvanized or stainless-steel framing and hardware with a non-slip plank or bar-grating as the walking surface. Base sizes are determined based on loading requirements for the support and load distribution to the roof.
8. **Size:** Surefoot Access Service Platforms are manufactured to project-specific dimensions and are to have limited-height adjustability to ensure a level surface and desired heights off the roof are achievable.
9. **Installation:** (1) Determine the required dimensions of the system including width, clearance height from the roof surface to the lowest point of the bridge section, desired elevations of the walking-working surface with respect to the roof surface and equipment to be serviced and the location of the unit on the roof, (2) assemble the Service Platform in the approximate location and make adjustments, as needed, to ensure each base rest firmly on the roof surface.  
  
MIRO recommends an additional sheet of roofing material, or a MIRO Support Pad be installed beneath each base. For built up roofs, remove all loose aggregate from an area 2 inches larger in width and length than the base or support pad and follow the installation directions outlined above.
10. **Spacing:** Surefoot Access Service Platforms are built to standards established in OSHA 1910 Subpart D for Walking-Working Surfaces. Contractors are to ensure clearances above and around crossovers are provided in accordance with OSHA Standards.
11. **Availability:** Surefoot Access Service Platforms are marketed throughout the United States through representatives and distributors.
12. **Maintenance:** Normal maintenance is not required. Semi-annual inspection is required to check platform position, and to ensure no hazardous conditions exists on or around the system.
13. **Technical Services:** Please call MIRO INDUSTRIES, INC: (800) 768-6978 or visit our website [www.miroind.com](http://www.miroind.com) for technical information and for graphic and CAD drawing downloads.

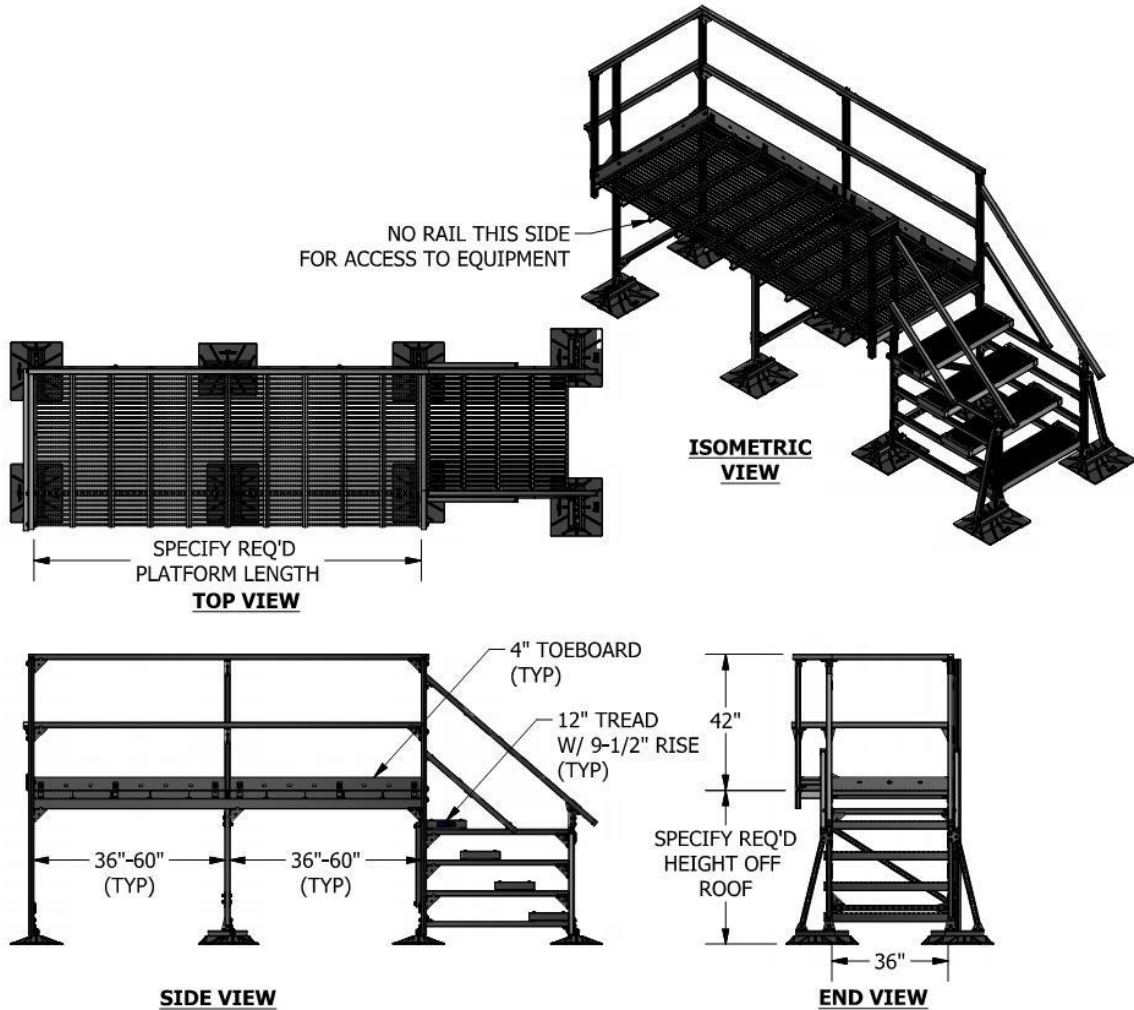

**ACCESSORIES**

- MIRO Support pad
- Eternabond® 2-sided tape

**PRODUCT DESCRIPTION**

MIRO Surefoot Service Platforms are custom designed in-house to meet project specific needs and code requirements. Bases and material are selected to meet design constraints and specifications.

MIRO crossover structures are designed to meet OSHA 1910 Subpart D requirements for walking/working surfaces. Anchorage of the crossover to the building structure may be required for applicable lateral and uplift loading.

**INSTALLATION PROCEDURES**

1. Typical MIRO Surefoot bridge crossover, walkway, service platform and ramp systems are shipped partially assembled. (Field assembly is required)
2. Use provided hardware and included drawings to build a suitable support.
3. Clear all loose gravel and aggregate away from base locations.
4. Place MIRO base on a MIRO Support Pad or other sacrificial pad for additional protection.
5. Make sure each base is firmly resting on the roof surface, making any necessary adjustments so that even-loading is distributed to the roof.

**CUSTOM SIZES AND LAYOUTS CAN BE DESIGNED TO MEET YOUR PROJECT REQUIREMENTS.**

The information contained in this drawing is the sole property of MIRO Industries, Inc. Any reproduction in part or as a whole without written permission of MIRO Industries, Inc. is prohibited.

DATE:  
JAN 2019

4 STEP SERVICE PLATFORM



## Product Data Sheet

# SUREFOOT ACCESS RAMP

1. **Product Name:** SUREFOOT ACCESS RAMP
2. **Manufacturer:** MIRO INDUSTRIES, INC.  
844 South 430 West, Suite 100,  
Heber City, Utah 84032  
Phone: (800) 768-6978  
Fax: (800) 440-7958
14. **Product Description:** Surefoot Access Ramps provide a safe and cost-effective means to access rooftop equipment. Surefoot Access Ramps are custom-designed to meet OSHA and building code standards for limited-access applications. Ramps can span across pipes, ducts, expansion joints, elevation changes and other potential obstructions. Ramps can be constructed to a maximum slope of 30 degrees, (6.9 units vertical to 12 units horizontal) per OSHA standards. Each ramp section is designed to carry applicable loading, per OSHA requirements, and distribute the loading to the roof surface through the frame system connected to either a polycarbonate, stainless-steel or hot-dip galvanized base. Each ramp is adjustable in the field via bolted connections to accommodate roof and height variations. All metal parts are made from either hot-dip galvanized steel or stainless-steel for outdoor weathering protection. Surefoot Access Ramps consists of (1) a MIRO designed base, with gently curved edges to protect the roof membrane that effectively distributes the weight over the maximum roof surface, (2) hot-dip galvanized steel strut or stainless-steel frame structure, and (3) galvanized planking, or bar grating with an anti-slip surface for walking on.
15. **Product Performance:** Surefoot Access Ramps provide a means to safely access rooftop equipment around physical obstacles. Ramps are an ideal solution where wheeled carts are used to move equipment and material across the roof. Ramps are typically set on the roof surface as a free-floating system, but positive attachment of the system to the building structure may be required for code compliance. Where required, a means for positive attachment to the building structure can be provided and coordinated by MIRO Industries.
16. **Compatibility:** Surefoot Access Ramps are recommended for use on, and are compatible with, all current types of decking and with all commonly used built-up and single-ply roofing membranes, where access across physical obstacles on a rooftop is required.
17. **Load Weight:** Maximum load weight is equivalent to and is part of the maximum roof top bearing load, which shall be determined for each ramp based on dimensions and the weight of the system. MIRO recommends loading not exceed 3 lbs. per square inch from each base to the roof surface. In addition, a deflection limit for frame members shall not exceed the span length divided by 360 ( $L/360$ ) and a maximum recommended deflection not to exceed 1/8 inch.
18. **Composition and Materials:** Ramps are made with either polycarbonate, hot-dip galvanized or stainless-steel bases and either hot-dip galvanized or stainless-steel framing and hardware with a non-slip plank or bar-grating as the walking surface. Base sizes are determined based on loading requirements for the support and load distribution to the roof.
19. **Size:** Surefoot Access Ramps are manufactured to project-specific dimensions and are to have limited-height adjustability to ensure a level surface and desired heights off the roof are achievable.
20. **Installation:** (1) Determine the required dimensions of the system including width, clearance height from the roof surface to the lowest point of the bridge section, and the location of the unit on the roof, (2) assemble the ramp in the approximate location and adjust the support as needed to ensure each base rest firmly on the roof surface.  

MIRO recommends an additional sheet of roofing material, or a MIRO Support Pad be installed beneath each base. For built up roofs, remove all loose aggregate from an area 2 inches larger in width and length than the base or support pad and follow the installation directions outlined above.
21. **Spacing:** Surefoot Access Ramps are built to standards established in OSHA 1910 Subpart D for Walking-Working Surfaces. Contractors are to ensure clearances above and around ramps are provided in accordance with OSHA Standards.
22. **Availability:** Surefoot Access Ramps are marketed throughout the United States through representatives and distributors.
23. **Maintenance:** Normal maintenance is not required. Semi-annual inspection is required to check ramp position, and to ensure no hazardous conditions exists on or around the system.
24. **Technical Services:** Please call MIRO INDUSTRIES, INC: (800) 768-6978 or visit our website [www.miroind.com](http://www.miroind.com) for technical information and for graphic and CAD drawing downloads.

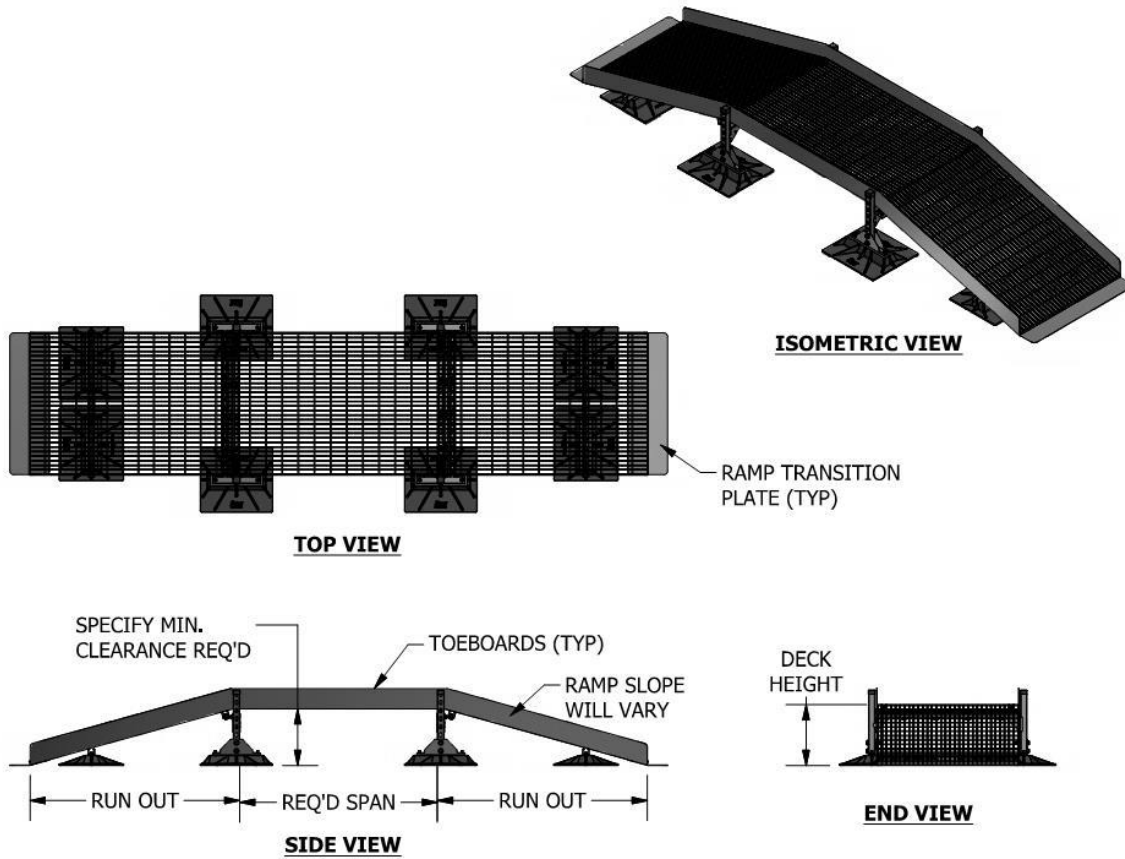

**ACCESSORIES**

- MIRO Support pad
- Eternabond® 2-sided tape

**PRODUCT DESCRIPTION**

The MIRO Surefoot Ramps are custom designed in-house to meet project specific needs and code requirements. Bases and material are selected to meet design constraints and specifications.

MIRO crossover structures are designed to meet OSHA 1910 Subpart D requirements for walking/working surfaces. Anchorage of the crossover to the building structure may be required for applicable lateral and uplift loading.

**INSTALLATION PROCEDURES**

1. Typical MIRO Surefoot bridge crossover, walkway, service platform and ramp systems are shipped partially assembled. (Field assembly is required)
2. Use provided hardware and included drawings to build a suitable support.
3. Clear all loose gravel and aggregate away from base locations.
4. Place MIRO base on a MIRO Support Pad or other sacrificial pad for additional protection.
5. Make sure each base is firmly resting on the roof surface, making any necessary adjustments so that even-loading is distributed to the roof.

<p>The information contained in this drawing is the sole property of MIRO Industries, Inc. Any reproduction in part or as a whole without written permission of MIRO Industries, Inc. is prohibited.</p>	<p>DATE: JAN 2019</p>	<p>CROSSOVER RAMP</p>
--	---------------------------	-----------------------

## Product Data Sheet

# SUREFOOT ACCESS WALKWAYS

1. **Product Name:** SUREFOOT ACCESS WALKWAYS
2. **Manufacturer:** MIRO INDUSTRIES, INC.  
844 South 430 West, Suite 100,  
Heber City, Utah 84032  
Phone: (800) 768-6978  
Fax: (800) 440-7958
3. **Product Description:** Surefoot Access Walkways provide a safe and cost-effective means to access rooftop equipment on sloped or uneven roofs. Surefoot Access Walkways are custom-designed to meet OSHA and building code standards for limited access applications. Walkways can be built to accommodate a variety of sloped roofs or can be built at specific heights to span across mechanical pipe, expansion joints, and other potential obstructions. Each walkway section is designed to carry applicable loading, per OSHA requirements, and distribute the loading to the roof surface through the frame system connected to either a polycarbonate, stainless-steel or hot-dip galvanized base. Each walkway is adjustable in the field via bolted connections to accommodate roof and height variations. All metal parts are made from either hot-dip galvanized steel or stainless-steel for outdoor weathering protection. Surefoot Access Walkways consists of (1) a MIRO designed base with gently curved edges to protect the roof membrane that effectively distributes the weight over the maximum roof surface, (2) hot-dip galvanized steel strut or stainless-steel frame structure, and (3) galvanized planking, or bar grating with an anti-slip surface for walking on.
4. **Product Performance:** Surefoot Access Walkways provide a clear and level surface to safely navigate a roof. Walkways are an ideal solution to direct rooftop traffic along designated pathways. Walkways are typically set on the roof surface as a free-floating system, but positive attachment of the system to the building structure may be required for sloped roofs and for code compliance. Where required, a means for positive attachment to the building structure can be provided and coordinated by MIRO Industries.
5. **Compatibility:** Surefoot Access Walkways are recommended for use on, and are compatible with, all current types of decking and with all commonly used built-up and single-ply roofing membranes, where access across physical obstacles on a rooftop is required.
6. **Load Weight:** Maximum load weight is equivalent to and is part of the maximum rooftop bearing load, which shall be determined for each walkway based on dimensions and the weight of the system. MIRO recommends loading not exceed 3 lbs. per square inch from each base to the roof surface. In addition, a deflection limit for frame members shall not exceed the span length divided by 360 ( $L/360$ ) and a maximum recommended deflection not to exceed 1/8 inch.
7. **Composition and Materials:** Walkways are made with either polycarbonate, hot-dip galvanized or stainless-steel bases and either hot-dip galvanized or stainless-steel framing and hardware with a non-slip plank or bar-grating as the walking surface. Base sizes are determined based on loading requirements for the support and load distribution to the roof.
8. **Size:** Surefoot Access Walkways are manufactured to project-specific dimensions and are to have limited-height adjustability to ensure a level surface and desired heights off the roof are achievable.
9. **Installation:** (1) Determine the required dimensions of the system including width, clearance height from the roof surface and a defined path for the walkway system, (2) assemble the walkway in the approximate location and adjust the support as needed to ensure each base rest firmly on the roof surface.  
  
MIRO recommends an additional sheet of roofing material, or a MIRO Support Pad be installed beneath each base. For built up roofs, remove all loose aggregate from an area 2 inches larger in width and length than the base or support pad and follow the installation directions outlined above.
10. **Spacing:** Surefoot Access Walkways are built to standards established in OSHA 1910 Subpart D for Walking-Working Surfaces. Contractors are to ensure clearances above and around Walkways are provided in accordance with OSHA Standards.
11. **Availability:** Surefoot Access Walkways are marketed throughout the United States through representatives and distributors.
12. **Maintenance:** Normal maintenance is not required. Semi-annual inspection is required to check walkway position, and to ensure no hazardous conditions exists on or around the system.
13. **Technical Services:** Please call MIRO INDUSTRIES, INC: (800) 768-6978 or visit our website [www.miroind.com](http://www.miroind.com) for technical information and for graphic and CAD drawing downloads.

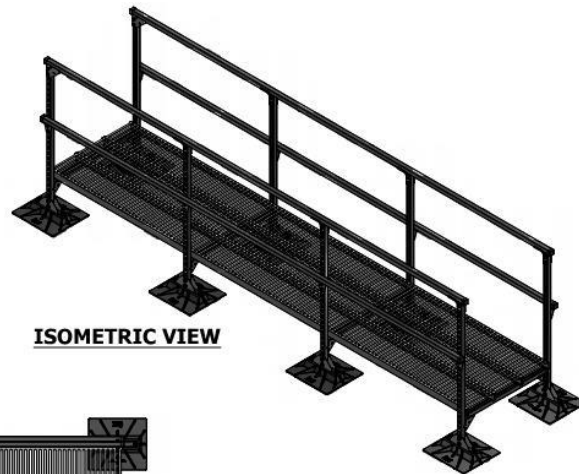

**ISOMETRIC VIEW**

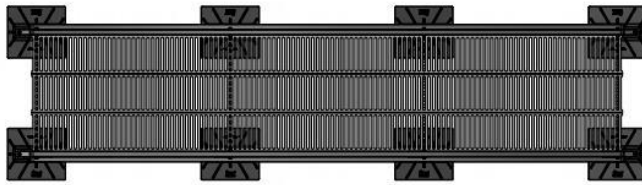

**TOP VIEW**

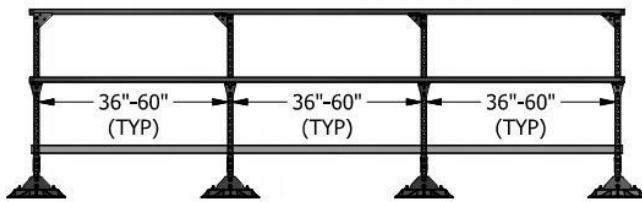

**SIDE VIEW**

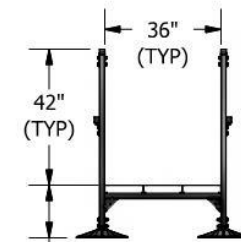

VARIES

**END VIEW**

**ACCESSORIES**

- MIRO Support pad
- Eternabond® 2-sided tape

**PRODUCT DESCRIPTION**

MIRO Surefoot walkways are custom designed in-house to meet project specific needs and code requirements. Bases and material are selected to meet design constraints and specifications.

MIRO crossover structures are designed to meet OSHA 1910 Subpart D requirements for walking/working surfaces. Anchorage of the crossover to the building structure may be required for applicable lateral and uplift loading.

**INSTALLATION PROCEDURES**

1. Typical MIRO Surefoot bridge crossover, walkway, service platform and ramp systems are shipped partially assembled. (Field assembly is required)
2. Use provided hardware and included drawings to build a suitable support.
3. Clear all loose gravel and aggregate away from base locations.
4. Place MIRO base on a MIRO Support Pad or other sacrificial pad for additional protection.
5. Make sure each base is firmly resting on the roof surface, making any necessary adjustments so that even-loading is distributed to the roof.

The information contained in this drawing is the sole property of MIRO Industries, Inc. Any reproduction in part or as a whole without written permission of MIRO Industries, Inc. is prohibited.

DATE:  
JAN 2019

WALKWAY





## **WIND AND SEISMIC**

Addressing lateral and uplift loading on rooftop equipment can be a challenging task. Typically, a support that is positively attached to the building structure is required to meet code-applicable minimum uplift and lateral loading. Additionally, a project-specific design and documentation prepared by a registered design professional are required to ensure code compliance is achieved. Concerning rooftop equipment and distribution lines, wind and seismic loading requirements can become significant, and are specifically addressed in mechanical codes and building codes.

MIRO Industries has in-house design professionals that can provide a code-compliant sealed submittal for supporting and restraining your rooftop equipment and distribution lines. Our objective, with any project, is to provide an economical and sustainable solution that meet equipment support and anchorage requirements. This means that we design solutions that are practical, less complex to install, and easily weatherproofed using typical roofing methods. MIRO Industries has 30+ years of experience providing support solutions for rooftop equipment that protect the integrity of your roof.

## Product Data Sheet

# SEISMIC & WIND COMPLIANT SYSTEMS

1. **Product Name:** SEISMIC & WIND COMPLIANT SYSTEMS
2. **Design Emphasis:** All MIRO products have the potential to be engineered and designed to be attached to the roof structure to meet seismic and wind up-lift codes.
3. **Manufacturer:** MIRO INDUSTRIES, INC.  
844 South 430 West, Suite 100,  
Heber City, Utah 84032  
Phone: (800) 768-6978  
Fax: (800) 440-7958
4. **Product Description:** An engineered stanchion support designed to meet project-specific criteria.
5. **Product Performance:** Anchored supports serve to keep the supported content (pipes, duct, electrical tray, etc.) vertically and laterally constrained, while allowing the supported component to move longitudinally, enabling free expansion and contraction of the supported component. The support is designed with a project-specific base arrangement to provide the required attachment to the structure to resist lateral, uplift and gravity loading to the frame. The project structural engineer is responsible for the design of the building structure and local reinforcement, where required, to withstand applied loads.
6. **Compatibility:** MIRO Seismic and Wind Supports will be designed and engineered to be compatible with all building constraints.
7. **Load Weight:** Seismic and Wind Supports are engineered to ensure member and component capacities and deflection criteria are not exceeded.
8. **Composition and Materials:** The support typically consists of three major components.: (1) Two hot-dip galvanized or stainless-steel stanchion bases with anchorage points designed per project specifications, (2) a braced strut assembly or hot-dip galvanized steel header, which his connected to the two stanchion bases, (3) A hanger system or tie down system, which will provide positive restraint in both the vertical and lateral directions, while allowing for some longitudinal expansion and contraction of the system supported.
9. **Size:** Seismic and Wind Supports are designed to project specific requirements. Where possible, a combination of stanchioned and free-floating supports are used to limit the number of roof penetrations, while meeting code minimums for applicable loading.
10. **Adjustable Height:** Seismic and Wind Supports, and their related configurations, allow for height adjustments as desired or required by the code or roof system. Each model can be configured to allow vertical and some lateral adjustment, as specified. Purchasers are to specify code design criteria, desired heights and spacing when inquiring about each project application.
11. **Installation Process:** (1) Locate the pipestand on the roof and anchor to the structure as specified (flashing and waterproofing of the roof surface is to be completed by others), (2) adjust the support to the desired height and to ensure even-load weight distribution among adjacent supports. Make certain the horizontal header is level. (3) Set the content in the support without dropping or causing any undue impact. Care should be taken during instillation to ensure each support carries a proportional and equal amount of weight.
12. **Spacing:** Space the supports as required by the project drawings. Do not exceed the specified load weight and make certain that each support is adjusted in height to evenly distribute the load among all supports.
13. **Availability:** Seismic and Wind Supports are marketed throughout the United States through representatives and distributors.
14. **Maintenance:** Normal maintenance is not required. Semi-annual inspection is required to check the alignment of the components being supported, to verify that weights are being distributed evenly, and to check for improper installation that may cause system failure or damage.
15. **Technical Services:** Please call MIRO INDUSTRIES, INC: (800) 768-6978 or visit our website [www.miroind.com](http://www.miroind.com) for technical information and for graphic and CAD drawing downloads.

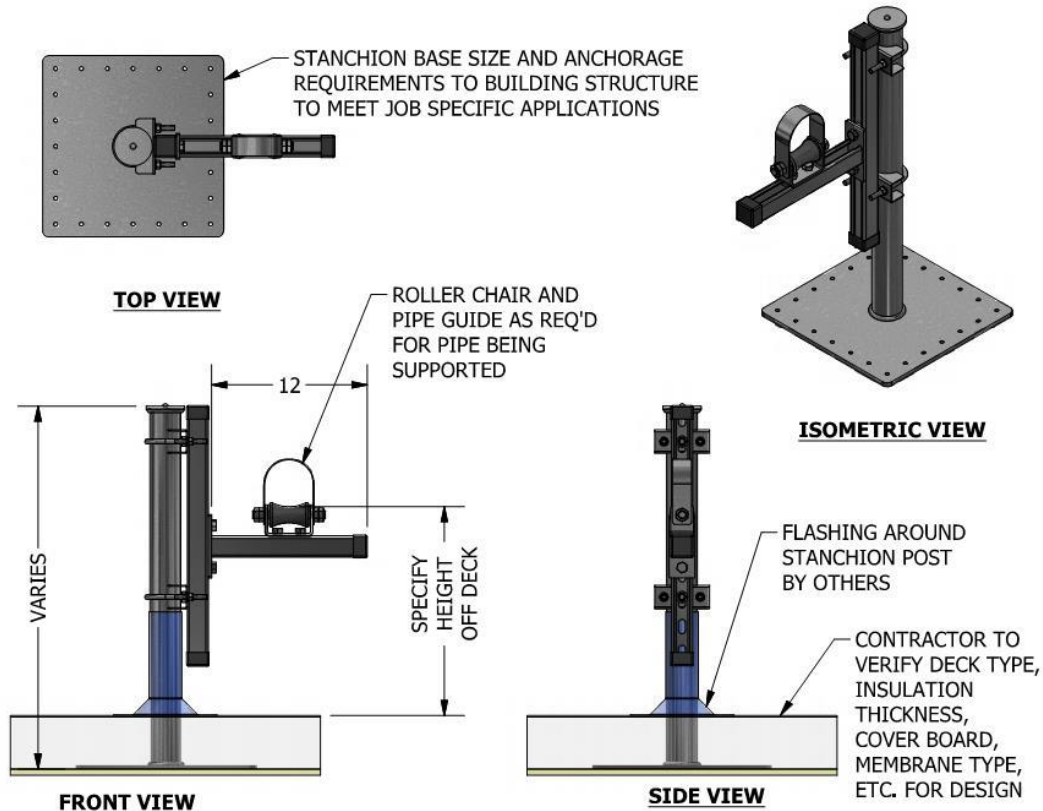

**PRODUCT DESCRIPTION**

Stanchioned pipe supports are designed for single or multiple pipes, single tier or multiple tier and for various heights.

To obtain pricing, call your local representative and have the following information available:

1. Type of pipe being supported (Steel Sch. 40)
2. Pipe size (trade size)
3. Pipe contents (liquid or gas)
4. Center line distance between pipes (CL)
5. Clearance height above roof deck (HOD)
6. Pipe insulation thickness.
7. Rooftop pipe layout drawing
8. Project Address
9. Roof framing plan
10. Cross section drawing of roof construction
  - a. Type of deck
  - b. Roof insulation thickness
  - c. Membrane or finished surface
11. MIRO Project Design Requirements sheet.

**KEY INFORMATION**

- Stanchioned pipe supports are designed and engineered to project specific requirements provided to MIRO Industries.
- MIRO Industries, Inc. is not responsible for the design or evaluation of the building structure or the design of the components being supported.
- Deflection in the horizontal header bar is not to exceed the span length by 360 or 1/8".
- Stanchioned pipe supports allow adjustable height as desired or required by the code or roof system. Purchasers must specify desired heights and multiple pipe centerline spacing upon quote requests and ordering of stanchioned pipe supports.
- Contractor is to ensure each pipestand is properly elevated to even distribute loading at all pipestands.
- All metal parts are hot dip galvanized or stainless steel

MIRO stanchioned supports are engineered to meet project specific design requirements. Stanchioned supports shall only be used on the project they are designed for. Supports are designed to meet loading requirements per ASCE-7 "Minimum Design Loads for Buildings and Other Structures" and locally adopted building codes.

The information contained in this drawing is the sole property of MIRO Industries, Inc. Any reproduction in part or as a whole without written permission of MIRO Industries, Inc. is prohibited.	DATE:	<b>SINGLE PIPE STANCHION SUPPORT</b>
	JAN 2019	



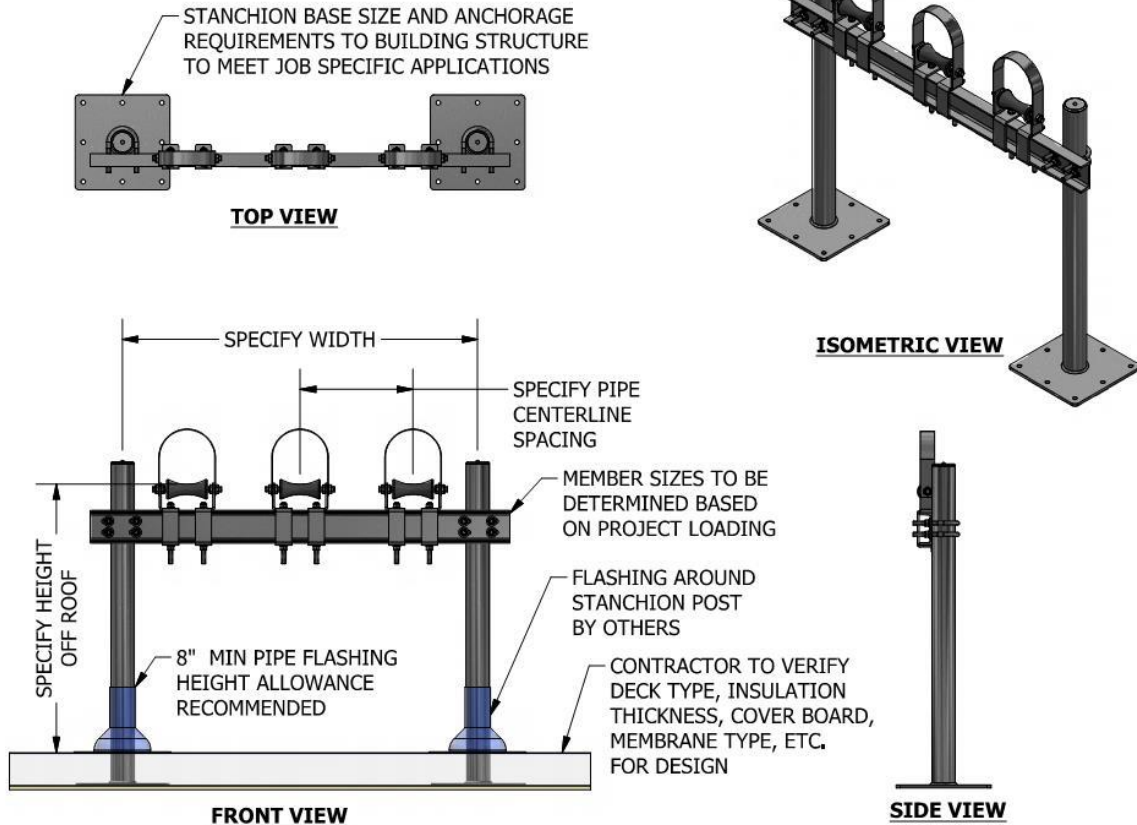

**PRODUCT DESCRIPTION**

Stanchioned pipe supports are designed for single or multiple pipes, single tier or multiple tier and for various heights.

To obtain pricing, call your local representative and have the following information available:

1. Type of pipe being supported (Steel Sch. 40)
2. Pipe size (trade size)
3. Pipe contents (liquid or gas)
4. Center line distance between pipes (CL)
5. Clearance height above roof deck (HOD)
6. Pipe insulation thickness.
7. Rooftop pipe layout drawing
8. Project Address
9. Roof framing plan
10. Cross section drawing of roof construction
  - a. Type of deck
  - b. Roof insulation thickness
  - c. Membrane or finished surface
11. MIRO Project Design Requirements sheet.

**KEY INFORMATION**

- Stanchioned pipe supports are designed and engineered to project specific requirements provided to MIRO Industries.
- MIRO Industries, Inc. is not responsible for the design or evaluation of the building structure or the design of the components being supported.
- Deflection in the horizontal header bar is not to exceed the span length by 360 or 1/8".
- Stanchioned pipe supports allow adjustable height as desired or required by the code or roof system. Purchasers must specify desired heights and multiple pipe centerline spacing upon quote requests and ordering of stanchioned pipe supports.
- Contractor is to ensure each pipestand is properly elevated to even distribute loading at all pipestands.
- All metal parts are hot dip galvanized or stainless steel

MIRO stanchioned supports are engineered to meet project specific design requirements. Stanchioned supports shall only be used on the project they are designed for. Supports are designed to meet loading requirements per ASCE-7 "Minimum Design Loads for Buildings and Other Structures" and locally adopted building codes.

The information contained in this drawing is the sole property of MIRO Industries, Inc. Any reproduction in part or as a whole without written permission of MIRO Industries, Inc. is prohibited.

DATE:  
JAN 2019

(#)RC STANCHION SUPPORT - CHANNEL



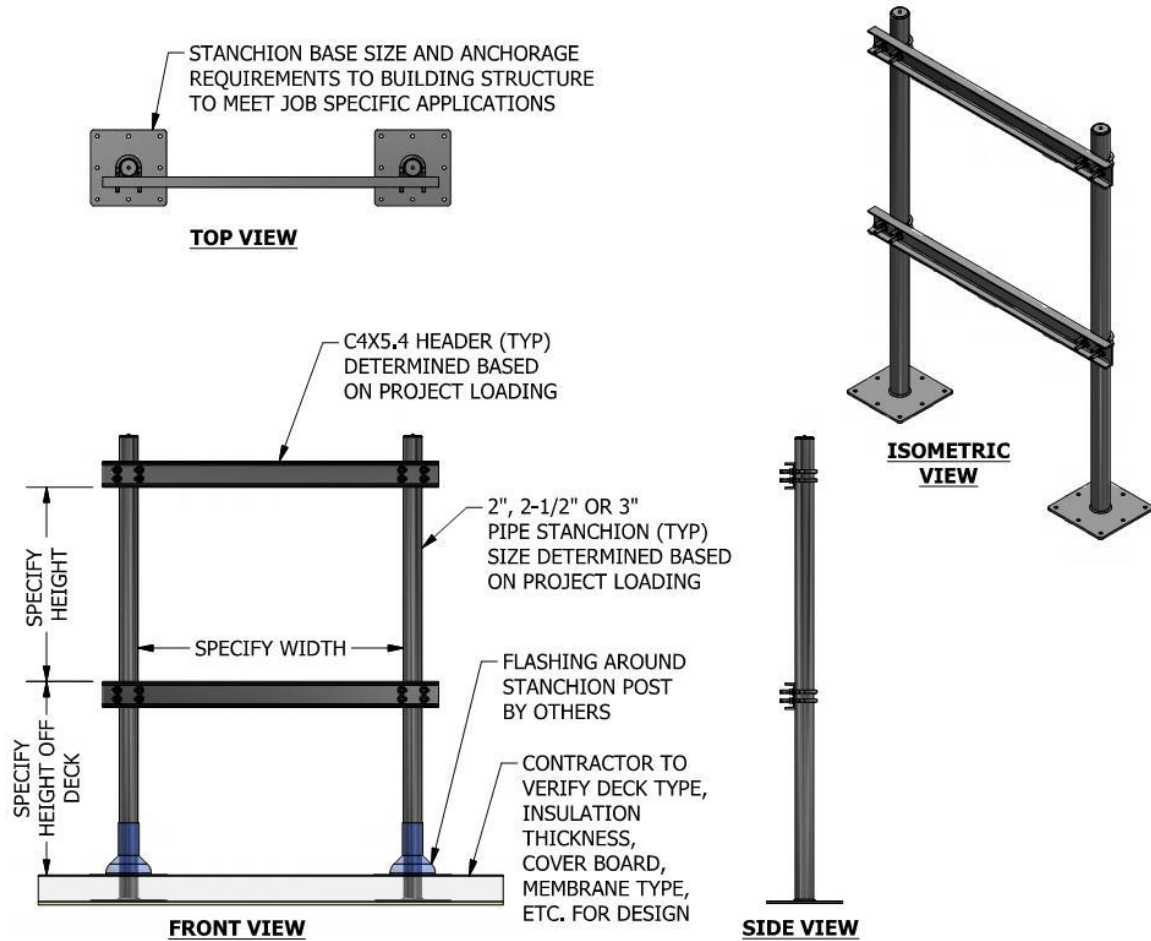

**PRODUCT DESCRIPTION**

Duct and Cable Trays are designed for single or multiple duct supports and cable trays. To obtain a project specific design and pricing, call your local representative and have the following information available:

1. Dimensions of duct
2. Duct material (gauge thickness)
3. Clearance height above roof (bottom of insulation)
4. Insulation (if any)
5. Duct layout drawing
6. Project Address
7. Roof framing plan
8. Cross section drawing of roof construction including; Type of deck, roof insulation thickness and membrane or finished surface
9. MIRO Project Specific Design Requirements sheet.

**KEY INFORMATION**

- Stanchioned duct supports are engineered to ensure member/component capacities and deflection criteria are not exceeded.
- Deflection in the horizontal header bar is not to exceed the span length by 360 or 1/8".
- Recommended spacing is not to exceed 8 feet centers depending upon the load.
- Width and height are built job specific based on information provided to MIRO Ind. with a minimum height of 12"
- All metal parts are hot dip galvanized
- MIRO Industries, Inc. is not responsible for the design of the building structure or the components being supported.

MIRO stanchioned supports are engineered to meet project specific design requirements. Stanchioned supports shall only be used on the project they are designed for. Supports are designed to meet loading requirements per ASCE-7 "Minimum Design Loads for Buildings and Other Structures" and locally adopted building codes.

The information contained in this drawing is the sole property of MIRO Industries, Inc. Any reproduction in part or as a whole without written permission of MIRO Industries, Inc. is prohibited.	DATE:	<b>STANCHIONED DS SUPPORT</b>
	JAN 2019	

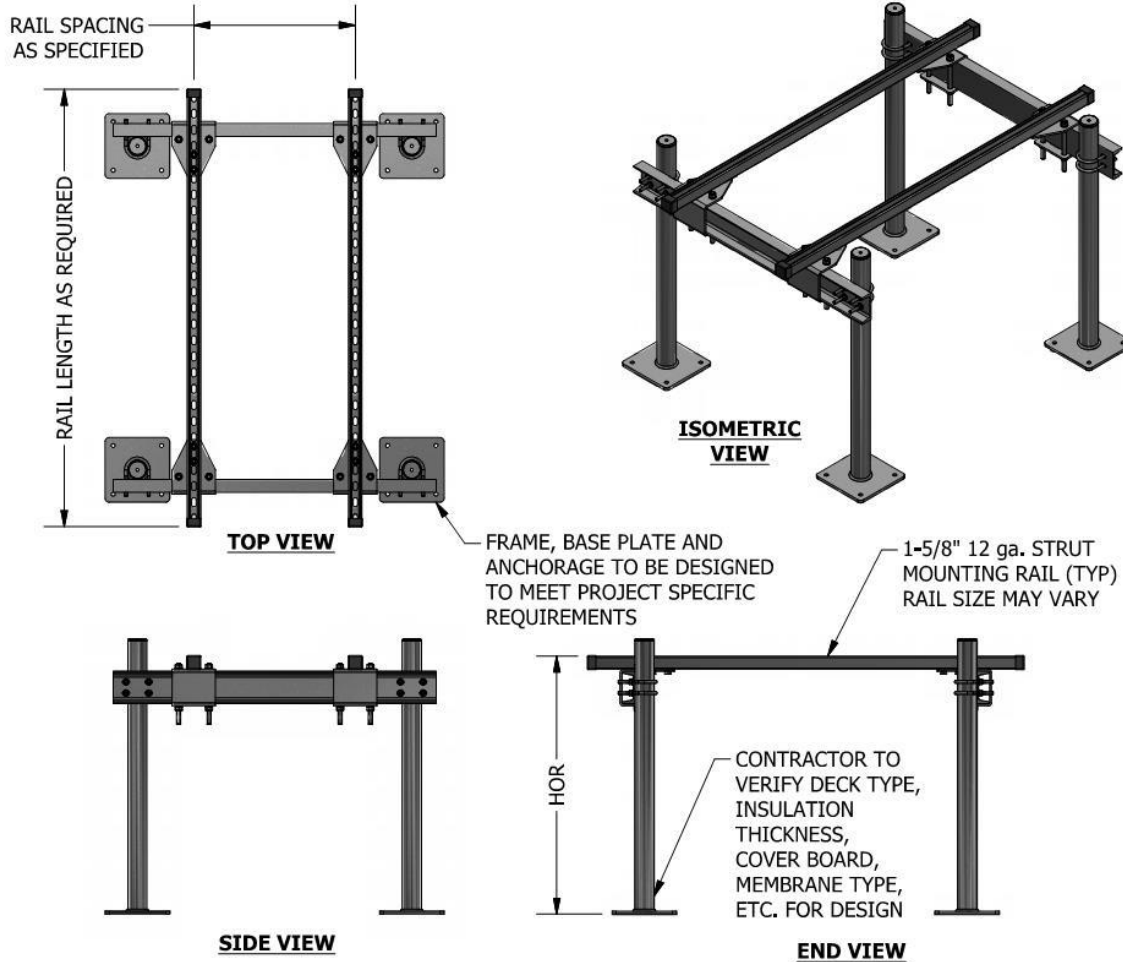

**PRODUCT DESCRIPTION**

MIRO Stanchioned HD Mechanical Supports are custom designed in-house to meet project specific needs and code requirements. Bases and material are selected to meet design constraints and specifications. Contractor is responsible for load verification unless provided otherwise by MIRO Industries.

Positive attachment to the building structure is typically required to resist minimum lateral and uplift loading requirements.

The project engineer of record is responsible for the design of the building structure and local reinforcement where required to withstand applied load.

**KEY INFORMATION**

Information needed to complete the design:

- Project Address
- Structural Drawings if available
- Design Criteria (typically available in the Structural General Notes)
- If structural drawings are not available a MIRO Design Professional can assist with obtaining the required information.
- Description of the intended use of the building
- Average Roof Height or elevation where equipment is being supported
- Cross-sectional view of roof construction
- All metal parts are either stainless steel or hot-dip galvanized.

The information contained in this drawing is the sole property of MIRO Industries, Inc. Any reproduction in part or as a whole without written permission of MIRO Industries, Inc. is prohibited.

DATE:  
JAN 2019

Stanchioned HD(Channel-Rail) Mechanical Support

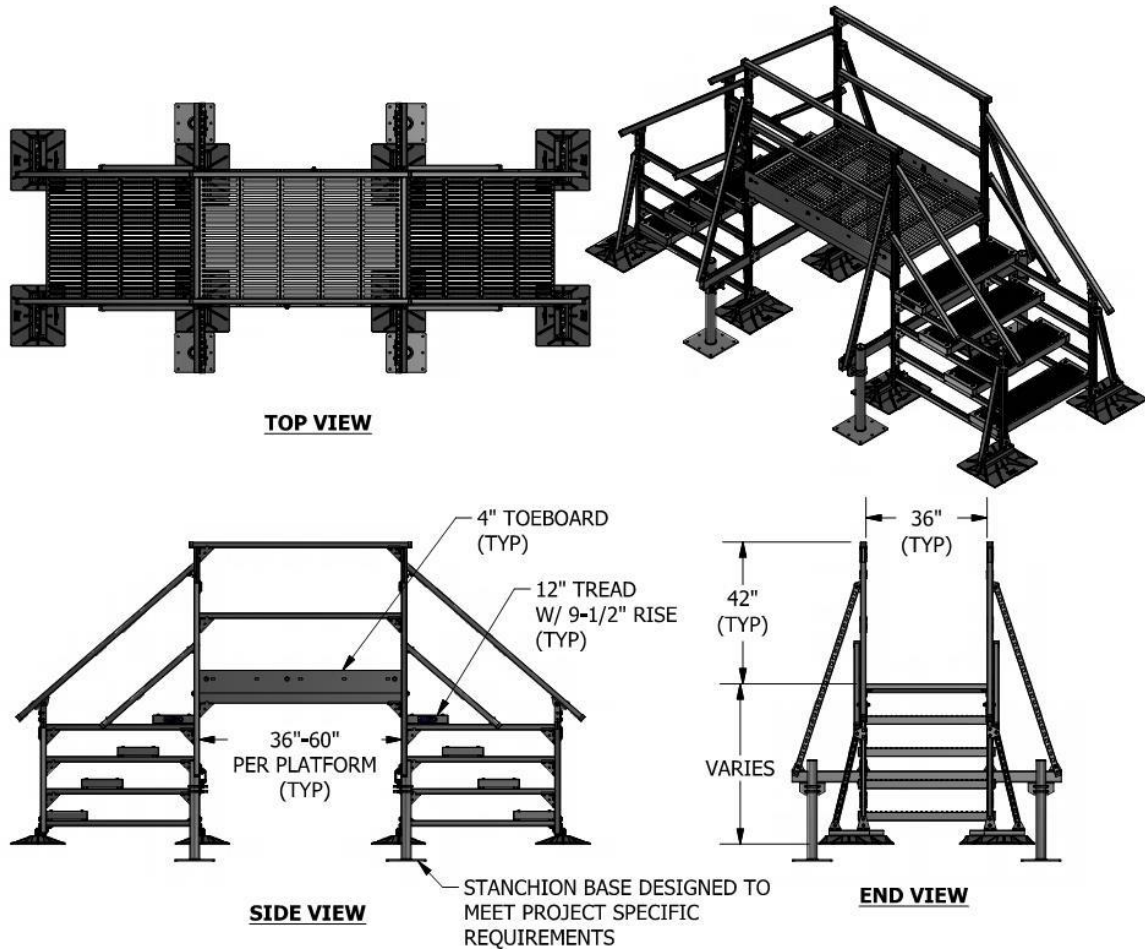

**PRODUCT DESCRIPTION**

On projects with high-wind and/or seismic risk, MIRO Surefoot access bridges and platforms may need to be positively anchored to the building structure. In these instances, MIRO Industries can provide a sealed engineered submittal package for the product that can be submitted to the local building official. Typical attachment requirements are addressed with a stanchion post attached directly to the roof deck. Force transfer through the building structure must be coordinated with the building engineer of record. The building engineer of record is responsible for the design of the building structure and local reinforcement where it is required to withstand applied loads.

MIRO crossover structures are designed to meet OSHA 1910 Subpart D requirements for walking/working surfaces. Stanchioned supports are also designed to code standards for applicable lateral and uplift loading.

**ACCESSORIES**

- MIRO Support pad
- Eternabond® 2-sided tape

**KEY INFORMATION**

Information needed to complete the design:

- Project Address
- Structural Drawings if available.
- Design Criteria (typically available in the Structural General Notes)
- If structural drawings are not available a MIRO Design Professional can assist with obtaining the required information.
- Description of the intended use of the building.
- Average Roof Height or elevation where crossover will be located.
- Cross-sectional view of roof construction
- All metal parts are either stainless steel or hot-dip galvanized.

<p>The information contained in this drawing is the sole property of MIRO Industries, Inc. Any reproduction in part or as a whole without written permission of MIRO Industries, Inc. is prohibited.</p>	<p>DATE: JAN 2019</p>	<p>STANCHIONED BRIDGE CROSSOVER</p>
--	---------------------------	-------------------------------------



## ACCESSORIES

MIRO Industries Accessory items are components that can be added to, or incorporated into, MIRO supports for additional function and peace of mind. Accessory items include the MIRO custom fitted support pads, spacers to increase the saddle height of the pillow block series supports, and pipe guides that ensure supported pipes do not become disengaged from supports. Additionally, parts that have been standardized to use with MIRO supports, and that are fabricated in house at MIRO Industries, can also be purchased as an accessory item.

Accessory items can be included with an initial product order, or they can be ordered later if conditions on your project change.

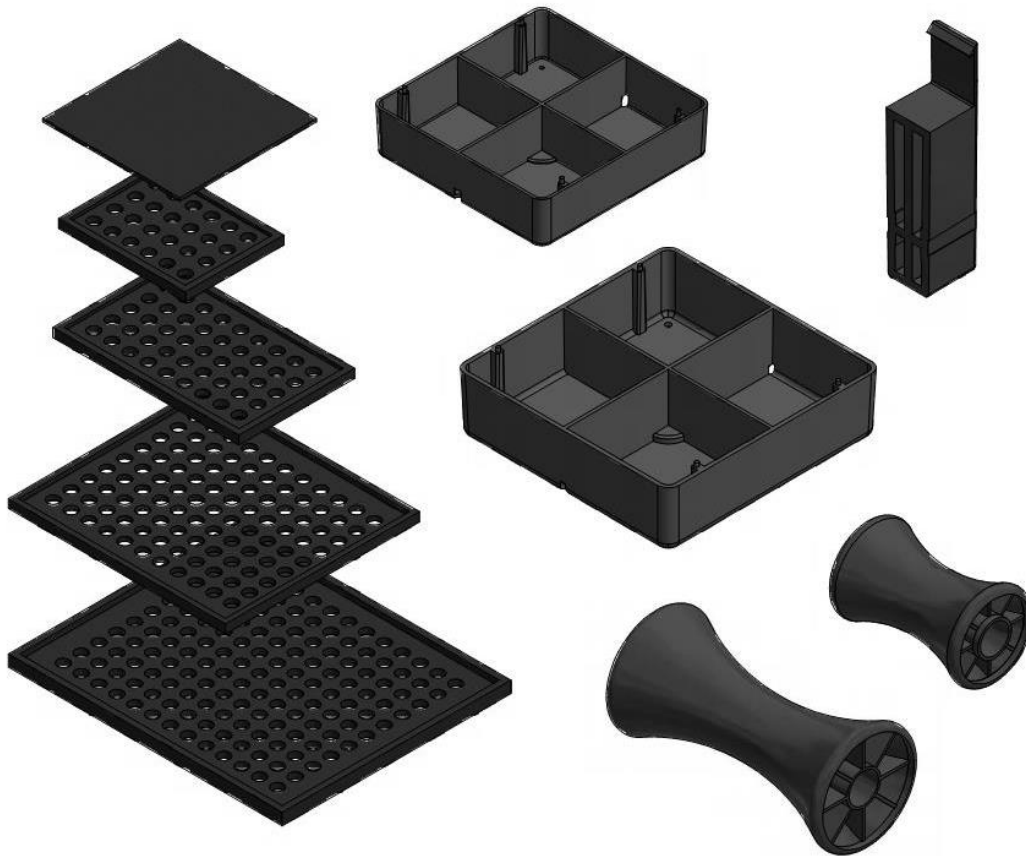



## Product Data Sheet

# SUPPORT PADS

1. **Product Name:** SUPPORT PAD, 12x12, 7½ x10, 9x15¼ 16x18 and 19x23.
2. **Manufacturer:** MIRO INDUSTRIES, INC.  
844 South 430 West, Suite 100,  
Heber City, Utah 84032  
Phone: (800) 768-6978  
Fax: (800) 440-7958
3. **Product Description:** MIRO Industries Support Pads are made of 100% heat-molded recycled rubber. Support Pads are designed to provide an additional barrier between the roof membrane and the rooftop equipment support. The support pads vary in size to accommodate MIRO's base and support options. MIRO Industries suggests the use of support pads under every MIRO Industries base. Installation requires that each base be properly placed evenly over each support pad.  
  
\*Note: The 12x12 support pad is a general fit pad without side lips or venting holes.
4. **Compatibility:** MIRO Support Pads are recommended and are compatible for use with most current types of decking and commonly used built-up and single-ply roof membranes.
5. **Installation:** Clean and prep the roof surface ensuring that the support pad will not be placed on any foreign debris. For built up roofs, remove all loose aggregate from an area 2 inches larger in width and length than the base or support pad and follow the installation directions outlined above.
6. **Maintenance:** Normal maintenance is not required. Semi-annual inspection is required to check pad position, pipe alignment, proper weight distribution, and improper installation, which may cause roof damage or failure.
7. **Availability:** Support Pads are marketed throughout the United States through representatives and distributors.
8. **Technical Services:** Please call MIRO INDUSTRIES, INC: (800) 768-6978 or visit our website [www.miroind.com](http://www.miroind.com) for technical information and for graphic and CAD drawing downloads.

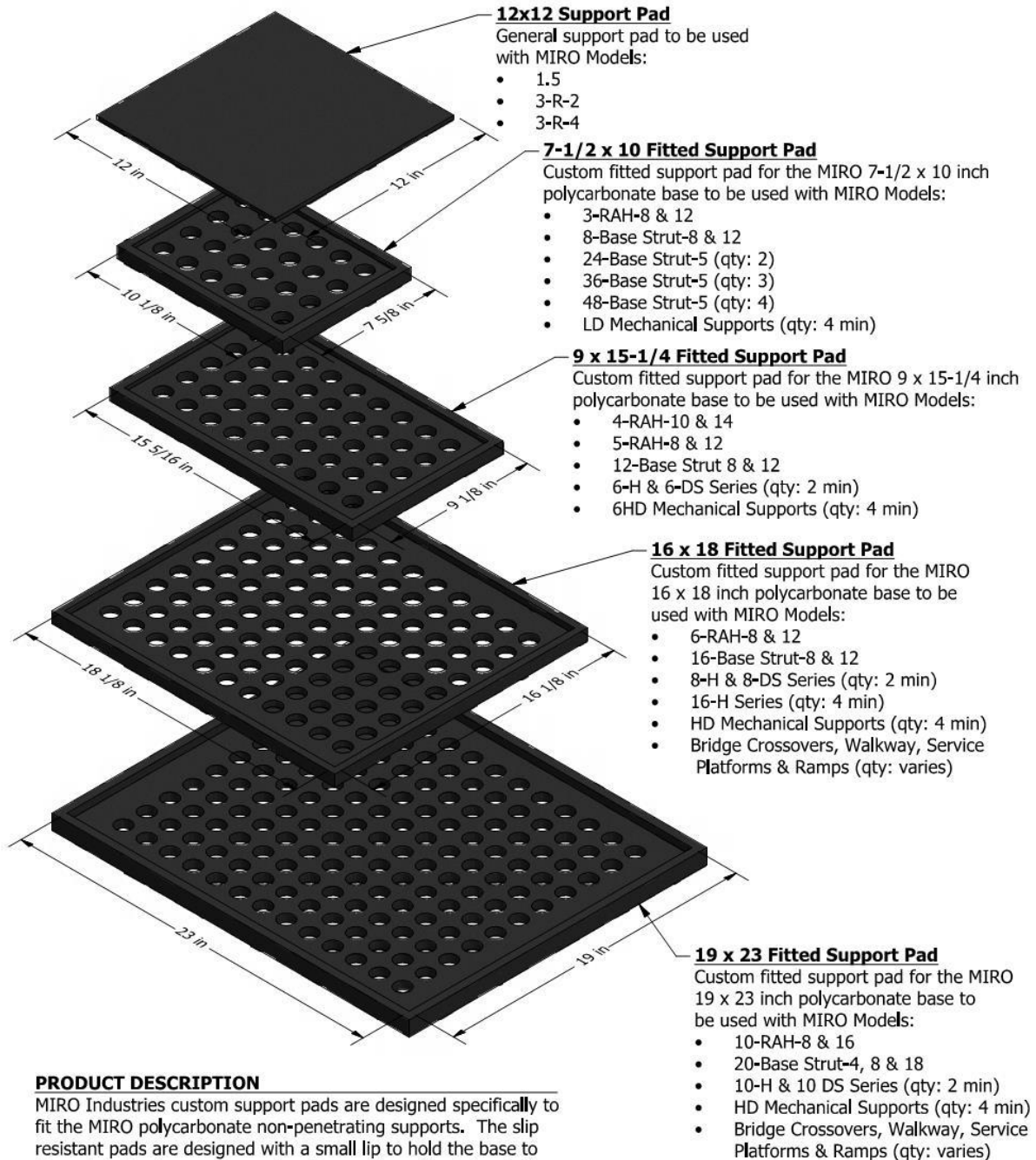

**PRODUCT DESCRIPTION**

MIRO Industries custom support pads are designed specifically to fit the MIRO polycarbonate non-penetrating supports. The slip resistant pads are designed with a small lip to hold the base to the pad and reduce movement on the rooftop. The holes in the pad saves weight and allows for venting and drainage. The pads are heat molded using 100% recycled rubber.

<p>The information contained in this drawing is the sole property of MIRO Industries, Inc. Any reproduction in part or as a whole without written permission of MIRO Industries, Inc. is prohibited.</p>	<p>DATE: JAN 2019</p>	<p>MIRO Support Pads</p>
--	---------------------------	--------------------------

## Product Data Sheet

### 1.5 SPACER

1. **Product Name:** PILLOW BLOCK PIPESTAND MODEL 1.5 SPACER NOTE: Pillow Block pipestand Model 1.5 Spacer is only used to stack under the model 1.5 support to increase the height of the 1.5 and the clearance of the pipe above the roof.
2. **Manufacturer:** MIRO INDUSTRIES, INC. Phone: (800) 768-6978  
844 South 430 West, Suite 100, Fax: (800) 440-7958  
Heber City, Utah 84032
3. **Product Description:** The Model 1.5 Spacer is 6 inches square and is designed to elevate the model 1.5 support an additional 1-1/2 inches. The 1.5 Spacer has gently rounded edges to prevent gouging of the roof surface. The 1.5 Spacer is to be placed directly under the Model 1.5 support, and up to a maximum of 3 spacers can be stacked together. Four drainage ports are provided to prevent ponding within the device. The dimensional area resting on the roof is 5-7/8 x 5-7/8 inches square, with a 34.52" square-inches surface area in contact with the roof surface.
4. **Compatibility:** Pillow Block Pipestands are recommended and are compatible for use with all current types of decking and with all commonly used built-up and single-ply roofing membranes, where roof-mounted pipes occur.
5. **Load Weight:** Maximum load-weight may not exceed 72 lbs. for the 1.5 pipestand.
6. **Composition and Materials:** The 1.5 Spacer consists of one-piece roof-deck-base made of polycarbonate resin with stacking alignment pins, and an interior cross hatch support structure. Carbon black is added for UV-resistance and protection.
7. **Size:** The 1.5 Spacer is made in one standard size. The deck base is 6" square with a height of 1½ inch. Each 1.5 Spacer increases the clearance of the pipe by an additional 1½ inches.
8. **Installation:** To install the spacers, locate the stacking and alignment pins on the spacers and the corresponding holes in the bottom of the 1.5 pipestand. Set the pipestands on the spacers, while making sure that the four pins are snug in the stacking holes. Follow the standard installation directions for the 1.5 pipestands below.  

To install the pillow block pipestand, (1) center the pipestand beneath the pipe so that the pipe will rest centered in the cradle of the pipestand. (2) Set the pipe in the pipestand without dropping or causing any undue impact. An additional sheet of roofing material, or a MIRO Support Pad should be installed beneath the pipestand. For built up roofs, clear all loose aggregate from an area 2 inches outside each base footprint and then follow the installation directions outlined above. Care should be taken to install each pipestand so it supports a proportional and equal amount of weight with all other pipestands.

In addition, the pipe may be secured to the pipestand by using a MIRO Pipe Guide and two #8 stainless-steel screws in the guide holes at the top of each pipestand. Note: the pipe guide should not be rigidly-attached to the pipe in the pipestand, thus allowing the supported pipe to expand and contract without binding.
9. **Spacing:** Manufacturer's recommended spacing is not to exceed 7 foot centers depending upon the load. Make certain each pipestand is properly elevated and adjusted to ensure even-load distribution to all pipestands. Support spacing is not to exceed the maximum spacing required in the pipe specifications, where applicable.
10. **Availability:** Pillow Block Pipestands are marketed throughout the United States through representatives and distributors.
11. **Maintenance:** Normal maintenance is not required. Semi-annual inspection is required to check pipestand position and set pipe alignment, check proper weight distribution, and to correct improper installation that may cause pipestand damage or failures.
12. **Technical Services:** Please call MIRO INDUSTRIES, INC: (800) 768-6978 or visit our website [www.miroind.com](http://www.miroind.com) for technical information and for graphic and CAD drawing downloads.

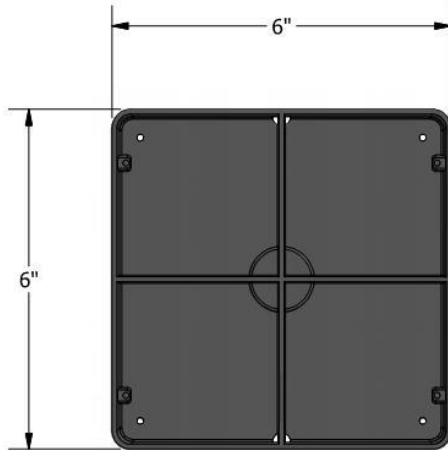

**TOP VIEW**

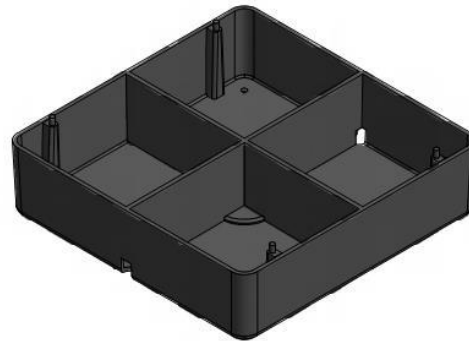

**ISOMETRIC VIEW**



**SIDE VIEW**

**Product Description**

The Model 1.5 Spacer is 6" square and the base is gently rounded to prevent gouging the roof. The outer edges are raised 1 1/2" and increased elevations may be achieved by stacking Model 1.5 on 1 or 2 spacers, each with a height of 1 1/2". Four drainage ports are provided to prevent ponding within the device. The dimensional area resting on the roof is 5 7/8" square, and 34.52 square inches are in contact with the roof.

The information contained in this drawing is the sole property of MIRO Industries, Inc. Any reproduction in part or as a whole without written permission of MIRO Industries, Inc. is prohibited.

DATE:  
JAN 2019

1.5 PILLOW BLOCK SPACER



## Product Data Sheet

### 3-R SPACER

1. **Product Name:** PILLOW BLOCK PIPESTAND MODEL 3-R SPACER NOTE: Pillow Block pipestand Model 3-R Spacer is only used to stack under the 3-R-2 and 3-R-4 models respectively to increase the height and the clearance of the pipe above the roof.
2. **Manufacturer:** MIRO INDUSTRIES, INC. Phone: (800) 768-6978  
844 South 430 West, Suite 100, Fax: (800) 440-7958  
Heber City, Utah 84032
3. **Product Description:** The Model 3-R Spacer is 7½ inches square and is designed to elevate the 3-R-2 and 3-R-4 model supports an additional 2 inches. The 3-R Spacer has gently rounded edges to prevent gouging of the roof surface. The 3-R Spacer is to be placed directly under the Model 3-R-2 or 3-R-4 support, and up to a maximum of 3 spacers can be stacked together. Two drainage ports are provided to prevent ponding within the device. The dimensional area resting on the roof is 7-1/2 x 7-1/2 inches square with a 52.56 square-inches surface area in contact with the roof surface.
4. **Compatibility:** Pillow Block Pipestands are recommended and are compatible for use with all current types of decking and with all commonly used built-up and single-ply roofing membranes where roof-mounted pipes occur.
5. **Load Weight:** Maximum load-weight may not exceed 118 lbs. for the 3-R-2 and 3-R-4 pipestands.
6. **Composition and Materials:** The 3-R Spacer consists of a one-piece roof-deck base made of polycarbonate resin with stacking alignment pins, and an interior cross hatch support structure. Carbon black is added for UV-resistance and protection.
7. **Size:** The 3-R Spacer is made in one standard size. The deck base is 7-1/2 x 7-1/2 inches square with an overall height 2 inches. Each 3-R spacer increases the clearance of the pipe by an additional 2".
8. **Installation:** To install the spacers, locate the stacking and alignment pins on the spacers and the corresponding holes in the bottom of the 3-R pipestands. Set the pipestands on the spacers, making sure that the four pins are snug in the stacking holes, and follow the installation directions for pipestands below.  

To install the pillow block pipestand, (1) center the pipestand beneath the pipe so that the pipe will rest centered directly on the roller. (2) Set the pipe in the pipestand without dropping or causing any undue impact. An additional sheet of roofing material, or a MIRO Support Pad should be installed beneath the pipestand. For built up roofs, clear all loose aggregate from an area 2 inches outside each base footprint, and then follow the installation directions outlined above. Care should be taken to install each pipestand so it supports a proportional and equal amount of weight with all other pipestands.

In addition, the pipe may be secured to the pipestand by using a MIRO Pipe Guide and two #8 stainless-steel screws in the guide holes at the top of each pipestand. **Note:** the pipe guide should not be rigidly-attached to the pipe in the pipestand, thus allowing the supported pipe to expand and contract without binding.
9. **Spacing:** Manufacturer's recommended spacing is not to exceed 7 foot centers depending upon the load. Make certain each pipestand is properly elevated and adjusted to ensure even-load distribution to all pipestands. Support spacing is not to exceed the maximum spacing required in the pipe specifications, where applicable.
10. **Availability:** Pillow Block Pipestands are marketed throughout the United States through representatives and distributors.
11. **Maintenance:** Normal maintenance is not required. Semi-annual inspection is required to check pipestand position and set pipe alignment, check proper weight distribution, and to correct improper installation that may cause pipestand damage or failures.
12. **Technical Services:** Please call MIRO INDUSTRIES, INC: (800) 768-6978 or visit our website [www.miroind.com](http://www.miroind.com) for technical information and for graphic and CAD drawing downloads.

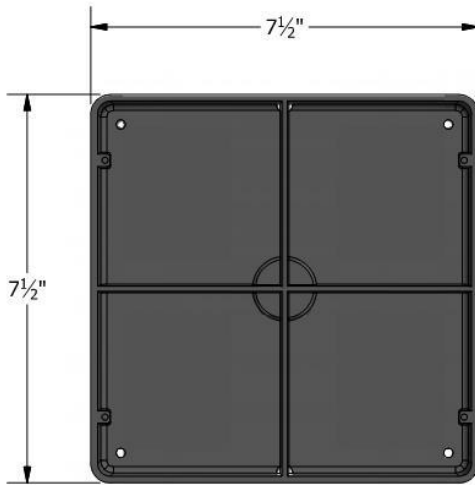

**TOP VIEW**

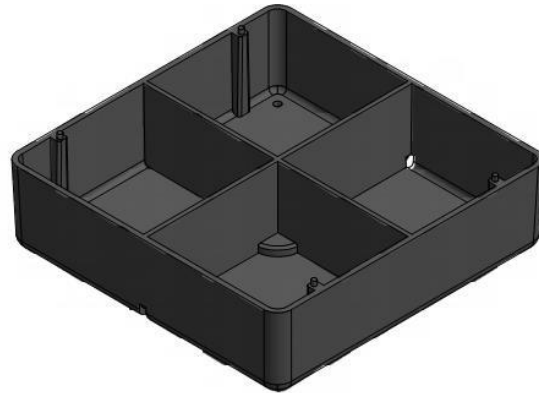

**ISOMETRIC VIEW**



**FRONT VIEW**

**Product Description**

The Model 3-R Spacer is 7½" square and the base is gently rounded to prevent gouging the roof. The outer edges are raised 2" and increased elevations may be achieved by stacking Model 3-R-2 or 3-R-4 on 1 or 2 spacers, each with a height of 2". Four drainage ports are provided to prevent ponding within the device. The dimensional area resting on the roof is 7½" inches square and 52.56 square inches are in contact with the roof.

The information contained in this drawing is the sole property of MIRO Industries, Inc. Any reproduction in part or as a whole without written permission of MIRO Industries, Inc. is prohibited.	DATE:	<b>3-R SPACER</b>
	JAN 2019	

## Product Data Sheet

### ROLLER 3 AND ROLLER 5

1. **Product Name:** MODEL ROLER 3 AND ROLLER 5 **NOTE:** MIRO Models Roller 3 and Roller 5 are the same rollers used on MIRO pipestands and may be purchased separately for other uses.
2. **Manufacturer:** MIRO INDUSTRIES, INC. Phone: (800) 768-6978  
844 South 430 West, Suite 100, Fax: (800) 440-7958  
Heber City, Utah 84032
3. **Product Description:** The Model Roller 3 and Model Roller 5 are heavy-duty support rollers made of polycarbonate resin.
4. **Compatibility:** The rollers are recommended and are compatible for use with all current types of metal, plastics and decking and with all commonly used built-up and singly-ply roofing membranes where roof-mounted pipes occur.
5. **Load Weight:** Maximum load weight may not exceed 335 lbs. for the Model 3 Roller and 578 lbs. for the Model 5 Roller. Both rollers are designed to accommodate a 5/8 inch diameter axle. User to verify axle and support capacity.
6. **Composition and Materials:** Both rollers consist of three components: (1) a concave bearing surface with a radius of 3" for the Roller 3 and a radius of 5" for the Roller 5, (2) both rollers have shaft openings of 5/8", and (3) the interior support structure consists of eight heavy duty walls radiating from the center shaft to the bearing surface.
7. **Size:** Roller 3 is 3 inches in length, the roller ends have a 1-7/8 inch diameter, has a 3 inch radius arch on the bearing surface, has a 5/8 inch shaft opening, requires a clearance of at least 15/16 inch from the center of the shaft opening, has a diameter of 1-1/4 inch at the center of the bearing surface, and loads on the bearing surface will be 5/16 inch above the supporting shaft.  
  
Roller 5 is 5 inches in length, the roller ends have a 2-7/16 inch diameter, has a 5 inch radius arch on the bearing surface, has a 5/8 inch shaft opening, requires a clearance of at least 1-7/32 inch from the center of the shaft opening, has a diameter of 1-1/4 inch at the center of the bearing surface, and loads on the bearing surface will be 5/16 inch above the supporting shaft.
8. **Installation:** Slide the roller over an appropriate shaft or axle to properly support the entire length of the roller so the roller will operate properly. Proper engineering on the load limits of the supporting shaft and the structure that supports the shaft are essential.
9. **Availability:** Rollers are marketed throughout the United States through representatives and distributors.
10. **Maintenance:** Normal maintenance is not required. Semi-annual inspection is required to check pipestand position and pipe alignment, check proper weight distribution and improper installation that may cause system failure or damage.
11. **Technical Services:** Please call MIRO INDUSTRIES, INC: (800) 768-6978 or visit our website [www.miroind.com](http://www.miroind.com) for technical information and for graphic and CAD drawing downloads.

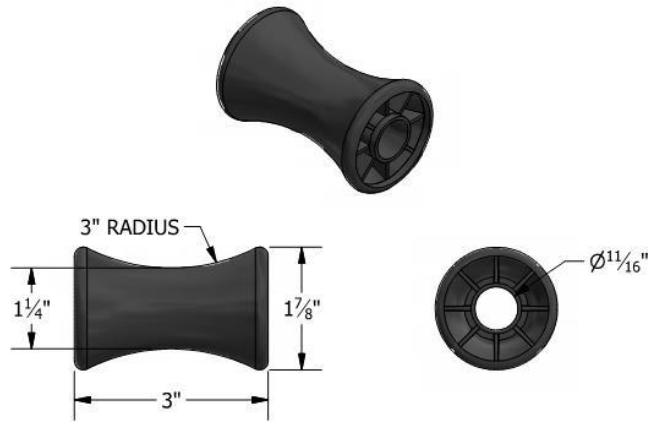

**ROLLER 3**



**ROLLER 5**

**Product Description**

The Model Roller 3 and Model Roller 5 are heavy-duty support rollers made of polycarbonate resin.

Both rollers consist of three components:

1. a concave bearing surface with a radius of 3" for the Roller 3 and a radius of 5" for the Roller 5
2. both rollers have shaft openings of 5/8"
3. the interior support structure consists of eight heavy duty walls radiating from the center shaft to the bearing surface.

Maximum load weight may not exceed 335 lbs. for the Model 3 Roller and 578 lbs. for the Model 5 Roller. Both rollers are designed to accommodate a 5/8 inch diameter axle. User to verify axle and support capacity.

The information contained in this drawing is the sole property of MIRO Industries, Inc. Any reproduction in part or as a whole without written permission of MIRO Industries, Inc. is prohibited.	DATE:	Roller 3 & Roller 5
	JAN 2019	



## Product Data Sheet

### 3-R Bracket

1. **Product Name:** Model 3-R Bracket
2. **Manufacturer:** MIRO INDUSTRIES, INC.  
844 South 430 West, Suite 100,  
Heber City, Utah 84032  
Phone: (800) 768-6978  
Fax: (800) 440-7958
3. **Product Description:** MIRO Industries 3-R Bracket is designed to be inserted into the Model 3-R-2 to raise the roller height clearance to 4 inches. The 3-R Brackets are sold individually and are inserted into existing 3-R-2 roof supports, or the Model 3-R-4 can be bought with the 3-R Bracket already inserted by the manufacturer.
4. **Installation:** Pull the polycarbonate roller and rod out of the 3-R-2 and insert one 3-R Bracket into each slot. The 3-R Bracket should be flush with the inner wall dimension and the bottom trough. Replace the polycarbonate roller and rod to fit on top of the new inserts.
5. **Availability:** The 3-R Brackets are marketed throughout the United States through representatives and distributors.
6. **Maintenance:** Normal maintenance is not required. Semi-annual inspection is required to check pipestand position and pipe alignment, check proper weight distribution and improper installation that may cause system failure or damage.
7. **Technical Services:** Please call MIRO INDUSTRIES, INC: (800) 768-6978 or visit our website [www.miroind.com](http://www.miroind.com) for technical information and for graphic and CAD drawing downloads.

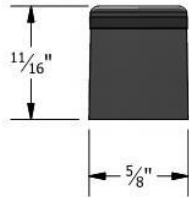

**TOP VIEW**



**ISOMETRIC VIEW**



**FRONT VIEW**

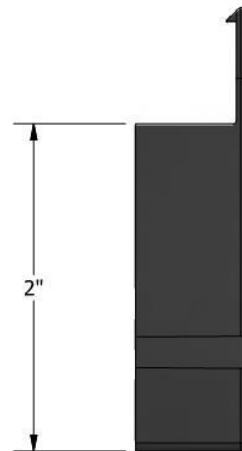

**SIDE VIEW**

**Product Description**

MIRO Industries 3-R Bracket is designed to be inserted into the Model 3-R-2 to raise the roller to give a height clearance of 4". The 3-R Brackets are sold as a pair to be inserted into existing 3-R-2 roof supports. Bracket is used to convert the model 3-R-2 to a 3-R-4. Refer to 3-R-4 for specifications and limitations.

The information contained in this drawing is the sole property of MIRO Industries, Inc. Any reproduction in part or as a whole without written permission of MIRO Industries, Inc. is prohibited.	DATE:	<b>3-R BRACKET</b>
	JAN 2019	

## Product Data Sheet

# PIPE GUIDES

1. **Product Name:** MIRO Model Pipe Guides
2. **Manufacturer:** MIRO INDUSTRIES, INC.  
844 South 430 West, Suite 100,  
Heber City, Utah 84032  
Phone: (800) 768-6978  
Fax: (800) 440-7958
3. **Product Description:** MIRO Industries Pipe Guides are designed to attach to MIRO Industries Pillow Block and Roller Series Supports to prevent supported pipe from becoming disengaged from the pipestand. All Pipe Guides will ship separately and will need to be installed on site. It is important to note that pipe guides should not be rigidly-attached to the pipe installed in the pipestand to allow for lateral thermal expansion and contraction of the pipe to occur within the pipestand. Pipe Guides are stocked in accordance with the optimally sized pipe for each support. **\*Custom pipe guides are available upon request. Please call MIRO Industries for more information.**
4. **Installation:**
  - Pillow Block Models 1.5, 3-R-2 and 3-R-4: Attach the Pipe Guide to the appropriate support using the included #8 phillips head stainless-steel screws into the molded holes on the top of the polycarbonate support.
  - Roller Series Support Models: Remove the nut from the vertical all-thread above the roller assembly. Install the appropriate Pipe Guide onto the vertical all-thread, and replace the nut securing the pipe guide in place.
5. **Availability:** MIRO Pipe Guides are marketed throughout the United States through representatives and distributors.
6. **Maintenance:** Normal maintenance is not required. Semi-annual inspection is required to check pipestand position and pipe alignment, check proper weight distribution and for improper installation that may cause system failure or damage.
7. **Technical Services:** Please call MIRO INDUSTRIES, INC: (800) 768-6978 or visit our website [www.miroind.com](http://www.miroind.com) for technical information and for graphic and CAD drawing downloads.

### 1.5 Pipe Guide

Guide material is 0.040 inch aluminum 5052 alloy temper H32 ASTM B-209-01.  
Included with 1.5 pipe guides are #8 stainless-steel screws that are to be used to attach the strap to molded holes in the top of the polycarbonate support.

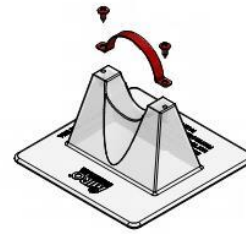

### 3-R-2 Pipe Guide

Guide material is 0.040 inch aluminum 5052 alloy temper H32 ASTM B-209-01.  
Included with 3-R-2 pipe guides are #8 stainless-steel screws that are to be used to attach the strap to molded holes in the top of the polycarbonate support.



### 3-R-4 Pipe Guide

Guide material is 0.040 inch aluminum 5052 alloy temper H32 ASTM B-209-01.  
Included with 3-R-4 pipe guides are #8 stainless-steel screws that are to be used to attach the strap to molded holes in the top of the polycarbonate support.

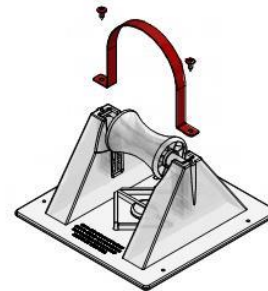

### 3-RAH-3 Inch Pipe Guide

Guide is 16 gauge (0.051 in) aluminum 5052 alloy temper H32 ASTM B-209-01  
Remove the two top hex nuts from the RAH assembly, install the pipe guide and replace the hex nuts.

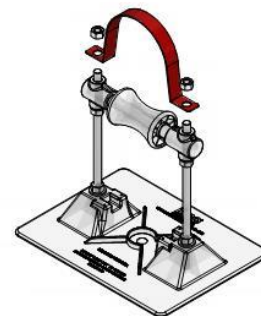



### 4-RAH 4 Inch Pipe Guide

Guide is 16 gauge (0.051 in) aluminum 5052 alloy temper H32 ASTM B-209-01  
Remove the two top hex nuts from the RAH assembly, install the pipe guide and replace the hex nuts.

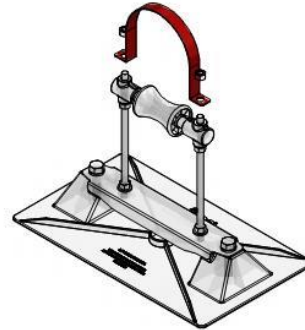

### 5-RAH-5 Inch Pipe Guide

Guide is 10 gauge (0.1019 in) aluminum 5052 alloy temper H32 ASTM B-209-01  
Remove the two top hex nuts from the RAH assembly, install the pipe guide and replace the hex nuts.

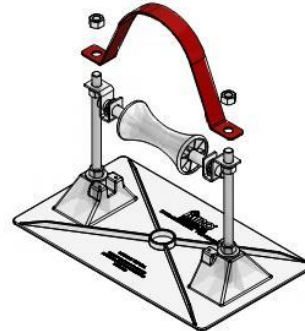

### 6-RAH-6 Inch Pipe Guide

Guide is 10 gauge (0.1019 in) aluminum 5052 alloy temper H32 ASTM B-209-01  
Remove the two top hex nuts from the RAH assembly, install the pipe guide and replace the hex nuts.

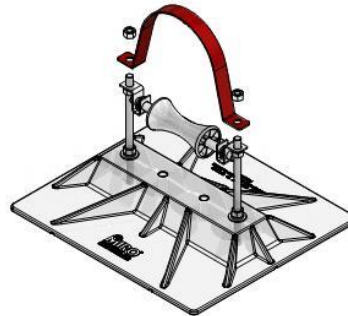

### 10-RAH-10 Inch Pipe Guide

Guide is 10 gauge (0.1019 in) A36 Steel with a hot-dip galvanized finish.  
Remove the two top hex nuts from the RAH assembly, install the pipe guide and replace the hex nuts.



## **Custom Product Pricing**

When quoting custom products, the following questions need to be answered:

### **PIPE**

1. Quantity of supports required (or total footage of pipe)
2. Type of Pipe
3. Size of pipe and number of pipes per support
4. Pipe contents
5. Center line distance between adjacent pipes for multiple pipe supports
6. Clearance height above roof
7. Thickness of any Insulation around pipe

### **DUCT OR “H” TYPE & CABLE TRAY SUPPORTS**

1. Dimension of duct
2. Duct material and wall thickness
3. Clearance height above roof
4. Total footage of duct
5. Thickness of insulation, if any
6. Does duct need to be enclosed

### **BRIDGE CROSSOVER, WALKWAY, SERVICE PLATFORM AND RAMP SYSTEMS**

1. Width and length desired
2. Height off roof
3. Specify if railing is needed
4. Type of roof

\*OSHA Standards

### **MECHANICAL SUPPORTS**

1. Width and length desired
2. Height off roof
3. Weight of unit

### **SEISMIC AND WIND UP-LIFT SUPPORTS**

1. Pipe and/or duct dimensions
2. Insulation
3. Lineal feet of pipe and/or duct
4. Clearance height off roof
5. General notes and index specification sheet

\*Call MIRO with Information listed above. MIRO will provide pricing and a general layout (where appropriate) in a timely manner.

## **SECTION 07 70 00**

# **ROOFTOP ACCESSORIES**

### **Part 2 GENERAL**

#### 2.1 SECTION INCLUDES

- A. Rooftop support products including:
  - 1. Pillow block pipe supports.
  - 2. Roller support series.
  - 3. Baser Strut support series.
  - 4. Custom hanger support series.
  - 5. Custom duct and cable tray support series.
  - 6. Mechanical supports.
  - 7. Surefoot access products.
  - 8. Accessories.

#### 2.2 RELATED SECTIONS

- A. Section 05 50 00 - Metal Fabrications.
- B. Division 07 - Thermal and Moisture Protection.
- C. Section 07 72 40 - Rooftop Walkways.
- D. Section 07 72 55 - Rooftop Pipe Support Systems.
- E. Section 21 05 29 - Hangers and Supports for Fire Suppression Pipe.
- F. Section 22 05 29 - Hangers and Supports for Plumbing Pipe and Equipment.
- G. Section 23 05 29 - Hangers and Supports for HVAC Piping and Equipment.
- H. Section 26 05 29 - Hangers and Supports for Electrical Systems.

#### 2.3 REFERENCES

- A. ASTM International (ASTM):
  - 1. ASTM A1011 SS GR33 - Standard Specification for hot rolled carbon steel sheet and strip, structural quality. (Hot Rolled Channel - Hot-Dipped Galvanized Finish).
  - 2. ASTM A123 - Standard Specification for Zinc (Hot-Dip Galvanized) Coatings on Iron and Steel Products.
  - 3. ASTM A153 - Standard Specification for zinc Coating (Hot-Dip) on Iron and Steel Hardware.
  - 4. ASTM A525 - Specification for General Requirements for Steel Sheet, Zinc-Coated (Galvanized) by the Hot-Dip Process.

5. ASTM D1929 - Standard Test Method for Determining Ignition Temperature of Plastics.
  - B. American National Standards Institute (ANSI):
    1. ANSI / MSS SP-58 - Pipe Hangers and Supports - Materials, Design, Manufacture, Selection, Application and Installation.
    2. ANSI / MSS SP-69 - Pipe Hangers and Supports - Selection and Application.
    3. ANSI / MSS SP-127 - Bracing for Piping Systems Seismic-Wind-Dynamic Design, Selection and Application.
  - C. American Iron and Steel Institute (AISI):
    1. AISI Specifications for the Design of Cold-Formed Steel Structural Members, 2007 Edition.
  - D. American Institute of Steel Construction (AISC):
    1. Steel Construction Manual, 14th Edition.
  - E. American Society of Civil Engineers (ASCE):
    1. ASCE 7 - Minimum Design Loads for Buildings and Other Structures.
  - F. International Code Council (ICC):
    1. International Building Code.
    2. International Mechanical Code.
    3. International Fuel and Gas Code.
  - G. Occupational Safety and Health Administration (OSHA):
    1. Safety and Health Regulations for Construction, Fall Protection.
    2. OSHA 1910, Subpart D, Walking and Working Surfaces.
- 1.4 SUBMITTALS
- A. Submit under provisions of Section 01 30 00 - Administrative Requirements.
  - B. Product Data: Manufacturer's data sheets on each product to be used, including:
    1. Preparation instructions and recommendations.
    2. Storage and handling requirements and recommendations.
    3. Installation methods.
  - C. Shop Drawings:
    1. Provide project-specific, engineered stamped shop drawings and calculations including extents of installation, load bearing capacity and structural requirements.
    2. Show installation layout, indicating product type and spacing. Coordinate with manufacturer's take-off evaluations, measurements, control dimensions, and rooftop requirements analysis.
    3. Show details of each roofing system including material layers and thicknesses, flashing, terminations, and penetrations with each rooftop support system to be installed.
    4. All supports shall be pre-assembled and shipped for turnkey installation. Indicate all



steps and preparation required by others.

- D. Verification Samples: Provide two full size units for each product to be installed.
- E. Manufacturer's Certification:
  - 1. New Construction Product Certificates: Manufacturer's product certification includes review of provided products in accordance with approved and accepted HVAC, Plumbing, Electrical or Equipment plans provided by others. Manufacturer is not responsible for evaluation, design, or certification of the building structure or equipment being supported. General Contractor shall verify project conditions prior to ordering products or submitting to manufacturer for review.
  - 2. Additions/Renovations Product Certificates: Manufacturer's product certification includes review and provided products in accordance with approved and accepted HVAC, Plumbing, Electrical or Equipment plans provided by others. Manufacturer is not responsible for evaluation, design, or certification of the building structure or equipment being supported. All existing conditions, dimensions, locations and elevations of existing equipment shall be verified by the General Contractor in the field and coordinated with new construction prior to preparation of shop drawings, fabrication, or commencement of work. If discrepancies are discovered between existing conditions and new work, the General Contractor shall immediately notify the Manufacturer prior to performance of shop drawings, fabrication, or commencement of work.
  - 3. Installer Qualifications: Certified by the manufacturer.

#### 1.5 QUALITY ASSURANCE

- A. Manufacturer Qualifications: Company with minimum 20 years of experience and specializing in the manufacture and distribution of engineered rooftop support systems.
  - 1. Manufacturer's custom work process shall include the following steps:
    - a. Project concept development and consulting.
    - b. Design and engineering including quantity and type of supports and accessories.
    - c. Fabrication and delivery.
    - d. On-site evaluation that installation meets specifications herein and manufacturer requirements.
    - e. Owner training and maintenance instruction.
- B. Installer Qualifications: Approved by the manufacturer, with minimum 5 years of experience installing similar products.
- C. Mock-Up: Provide a mock-up for evaluation of surface preparation techniques and application workmanship.
  - 1. Finish areas designated by Architect.
  - 2. Do not proceed with remaining work until workmanship is approved by Architect.
  - 3. Refinish mock-up area as required to produce acceptable work.

#### 1.6 PRE-INSTALLATION MEETINGS

- A. After approval of submittals, but before beginning installation, conduct a meeting at the Project site including:
  - 1. Attendance shall include the Architect, Contractor, roofing installers, mechanical,

electrical and other trades whose work will be installed in support system.

2. Describe the installation process in detail to establish responsibilities and project specific requirements and site logistics.
3. Prepare detailed meeting report and distribute to all attendees.

#### 1.7 DELIVERY, STORAGE, AND HANDLING

- A. Deliver and store products in manufacturer's unopened packaging bearing the brand name and manufacturer's identification, product model names and catalog numbers, and related information until ready for installation.
- B. Store materials off the ground under ventilated covers until ready for installation.
- C. Handle materials to avoid damage.

#### 1.8 PROJECT CONDITIONS

- A. Quantity Take Off: A manufacturer certified technician shall perform on-site quantity take-off including the following:
  1. Field measurements.
    - a. Where field measurements are not possible during design or construction, show control dimensions and project specific information on shop drawings.
  2. Design and layout.
  3. Product designation and tagging.
- B. Do not install products under environmental conditions outside manufacturer's recommended limits.
- C. Coordinate with roofing, mechanical, electrical and other related trades as required.

#### 1.9 SEQUENCING

- A. Ensure that products of this section are supplied to affected trades in time to prevent interruption of construction progress.

#### 1.10 WARRANTY

- A. Provide manufacturers standard product warranty against defects in manufacturing, proper operation, and against damaging roofing membrane when products are installed in accordance with engineered shop drawings and manufacturer's instructions. Warranty is not a maintenance agreement, insurance policy or obligation to repair leaks determined to be a result of the building design, installation, construction error, misuse of system, failure to inspect or maintain system or other limitations in manufacturer's standard warranty.
  1. Warranty Period: 20 years.

## Part 2 PRODUCTS

### 2.1 MANUFACTURERS

- A. Acceptable Manufacturer: MIRO Industries Inc., which is located at: 844 S. 430 W. Suite 100; Heber City, UT 84032; Toll Free Tel: 800-768-6978; Tel: 801-975-9993; Fax: 800-440-7958; Email:[sales@miroind.com](mailto:sales@miroind.com); Web: [www.miroind.com](http://www.miroind.com)

### 2.2 GENERAL

- A. The unique design absorbs thermal expansion and contraction of pipes to prevent damage to roofing membranes using non-corrosive bases that rest on roofing membranes including:
  - 1. Gently rounded edges to prevent damage to roofing membrane.
  - 2. Drainage ports to prevent ponding.
  - 3. Carbon black additive in polycarbonate for UV stabilization, stainless-steel and hot-dipped galvanized bases are available as specified below.
- B. Loading and Design Constraints:
  - 1. Design values are based on rooftop applications only. For other applications contact manufacturer for allowable loading.
  - 2. Maximum loading from any type of MIRO base to finished roof surface not to exceed 3.0 psi (0.021 Mpa) unless specifically indicated in project specifications.
  - 3. Horizontal deflection not to exceed the span length divided by 360 ( $l/360$ ) or 1/8 inch (3.175 mm).
  - 4. Include manufacturer's pipe guides, spacers, clamps, support pads, 2-sided tape and other recommended accessories.

### 2.3 PILLOW BLOCK PIPE SUPPORTS

- A. 1.5 - Pillow Block: Pipe support for roof-mounted gas pipes, electrical conduit, solar, or other mechanical piping with the following properties:
  - 1. Base Material: Polycarbonate.
  - 2. Deck Base: 6 inches (152 mm) square
  - 3. Pipe Clearance: Fixed height of 2 inches (518 mm). Each 1.5 spacer increases the clearance of the pipe by 1-1/2 inches (38 mm).
  - 4. Maximum Load Weight: 72 pounds (32 kg) per pipestand.
  - 5. Pipe Rest: "U-shaped" cradle in a polycarbonate resin seat.
  - 6. Support is designed to carry up to a 1-1/2 inch pipe with a max outside diameter of 1.9 inches (48 mm).
  - 7. Spacing: Horizontal support spacing per pipe specification, or horizontal pipe support intervals per the appropriate code or standard. Manufacturer's suggested spacing shall not exceed 7 foot (2 m) centers, as loading permits.
- B. 3-R-2 - Pillow Block: Roller bearing pipe support for roof-mounted gas pipes, electrical conduit, solar, or other mechanical piping with the following properties:
  - 1. Base Material: Polycarbonate.
  - 2. Deck Base: 7-3/4 inches (197 mm) square.
  - 3. Pipe Clearance: Fixed height of 2-1/8 inches (54 mm). Each 3-R spacer increases the clearance of the pipe by 2 inches (50 mm).
  - 4. Maximum Load Weight: 118 pounds (53 kg) per pipestand.
  - 5. Pipe Rest: Self-lubricating polycarbonate resin roller and axle.
  - 6. Support is designed to carry up to a 3 inch pipe with a maximum outside diameter of 3-3/4 inches (95 mm).
  - 7. Top of the Cradle: 4 inches (102 mm).
  - 8. Spacing: Horizontal support spacing per pipe specification, or horizontal pipe support

intervals per the appropriate code or standard. Manufacturer's suggested spacing shall not exceed 7 foot (2 m) centers, as loading permits.

- C. 3-R-4 - Pillow Block: Roller bearing pipe support for roof-mounted gas pipes, electrical conduit, solar, or other mechanical piping with the following properties:
1. Base Material: Polycarbonate.
  2. Deck Base: 7-3/4 inches (197 mm) square.
  3. Pipe Clearance: Fixed height of 4-1/8 inches (105 mm). Each 3-R spacer increases the clearance of the pipe by 2 inches (50 mm).
  4. Maximum Load Weight: 118 pounds (53 kg) per pipestand.
  5. Pipe Rest: Self-lubricating polycarbonate resin roller and axle.
  6. Support is designed to carry up to a 3 inch pipe with a maximum outside diameter of 3-3/4 inches (95 mm).
  7. Top of the Cradle: 4 inches (102 mm).
  8. Spacing: Horizontal support spacing per pipe specification, or horizontal pipe support intervals per the appropriate code or standard. Manufacturer's suggested spacing shall not exceed 7 foot (2 m) centers, as loading permits.

## 2.4 ROLLER SUPPORT SERIES

- A. 3-RAH-8: Roller bearing pipe support for roof-mounted gas pipes, electrical conduit, solar, or other mechanical piping with the following properties:
1. Base Material: Polycarbonate.
  2. Deck Base: 7-1/2 x 10 inch (190 x 254 mm).
  3. Pipe Clearance: Adjustable from the factory-set maximum height of 8 inches (203 mm) down to a minimum of 3-7/8 inches (98 mm).
  4. Maximum Load Weight, Polycarbonate: 172 pounds (78 kg) per pipestand.
  5. Pipe Rest: Self-lubricating polycarbonate resin roller, axle and collar.
  6. Support All-Thread and Metal Parts: Stainless-steel.
  7. Support is optimally designed to carry up to a 3 inch pipe.
  8. Maximum pipe outside diameter (with insulation) is 5-1/2 inches (140 mm).
  9. Spacing: Horizontal support spacing is per pipe specification, or horizontal pipe support intervals per the appropriate code or standard. Manufacturer's suggested spacing shall not exceed 10 foot (3 m) centers, as loading permits.
  10. If supporting insulated pipe, a shield or saddle shall be used.
- B. 3-RAH-12: Roller bearing pipe support for roof-mounted gas pipes, electrical conduit, solar, or other mechanical piping with the following properties:
1. Base Material: Polycarbonate.
  2. Deck Base: 7-1/2 x 10 inch (190 x 254 mm).
  3. Pipe Clearance: Adjustable from the factory-set maximum height of 12 inches (305 mm) down to a minimum of 3-7/8 inches (98 mm).
  4. Maximum Load Weight: 172 pounds (78 kg) per pipestand.
  5. Pipe Rest: Self-lubricating polycarbonate resin roller, axle, and collar.



6. Support All-Thread and Metal Parts: Stainless-steel.
  7. Support is optimally designed to carry up to a 3 inch pipe.
  8. Maximum pipe outside diameter (with insulation) is 5-1/2 inches (140 mm).
  9. Spacing: Horizontal support spacing per pipe specification, or horizontal pipe support intervals per the appropriate code or standard. Manufacturer's suggested spacing shall not exceed 10 foot (3 m) centers, as loading permits.
  10. If supporting insulated pipe, a shield or saddle shall be used.
- C. 4-RAH-8 SS: Roller bearing pipe support for roof-mounted gas pipes, electrical conduit, solar, or other mechanical piping with the following properties:
1. Base Material: Type 304 Stainless-steel.
  2. Deck Base: 12 x 16 inch (305 x 406 mm).
  3. Pipe Clearance: Adjustable from the factory-set maximum height of 8 inches (203 mm) down to a minimum of 3-3/4 inches (95 mm).
  4. Maximum Load Weight on Base: 419 pounds (190 kg) per pipestand.
  5. Pipe Rest: Self-lubricating polycarbonate resin roller, axle and collar.
  6. Support All-Thread and Metal Brackets: Stainless-steel or Hot-Dipped Galvanized.
  7. Support is optimally designed to carry up to a 4 inch pipe.
  8. Maximum pipe outside diameter (with insulation) is 5-1/2 inches (140 mm).
  9. Spacing: Horizontal support spacing per pipe specification, or horizontal pipe support intervals per the appropriate code or standard. Manufacturer's suggested spacing shall not exceed 10 foot (3 m) centers, as loading permits.
  10. If supporting insulated pipe, a shield or saddle shall be used.
- D. 4-RAH-10: Roller bearing pipe support for roof-mounted gas pipes, electrical conduit, solar, or other mechanical piping with the following properties:
1. Base Material: Polycarbonate.
  2. Deck Base: 9 x 15-1/4 inch (228 x 387 mm).
  3. Pipe Clearance: Adjustable from the factory-set maximum height of 9-5/8 inches (245 mm) down to a minimum of 4-1/2 inches (114 mm).
  4. Maximum Load Weight on Base: 335 pounds (152 kg) per pipestand.
  5. Pipe Rest: Self-lubricating polycarbonate resin roller, axle and collar.
  6. Support All-Thread and Metal Brackets: Stainless-steel or Hot-Dipped Galvanized.
  7. Support is optimally designed to carry up to a 4 inch pipe.
  8. Maximum pipe outside diameter (with insulation) is 5-1/2 inches (140 mm).
  9. Spacing: Horizontal support spacing per pipe specification, or horizontal pipe support intervals per the appropriate code or standard. Manufacturer's suggested spacing shall not exceed 10 foot (3 m) centers, as loading permits.
  10. If supporting insulated pipe, a shield or saddle shall be used.
- E. 4-RAH-12 SS: Roller bearing pipe support for roof-mounted gas pipes, electrical conduit, solar, or other mechanical piping with the following properties:
1. Base Material: Type 304 Stainless-steel.

2. Deck Base: 12 x 16 inch (305 x 406 mm).
  3. Pipe Clearance: Adjustable from the factory-set maximum height of 12 inches (305 mm) down to a minimum of 3-3/4 inches (95 mm).
  4. Maximum Load Weight on Base: 186 pounds (84 kg) per pipestand.
  5. Pipe Rest: Self-lubricating polycarbonate resin roller, axle, and collar.
  6. Support All-Thread and Metal Parts: Stainless-steel.
  7. Support is optimally designed to carry up to a 4 inch pipe.
  8. Maximum pipe outside diameter (with insulation) is 5-1/2 inches (140 mm).
  9. Spacing: Horizontal support spacing per pipe specification, or horizontal pipe support intervals per the appropriate code or standard. Manufacturer's suggested spacing shall not exceed 10 foot (3 m) centers, as loading permits.
  10. If supporting insulated pipe, a shield or saddle shall be used.
- F. 4-RAH-14: Roller bearing pipe support for roof-mounted gas pipes, electrical conduit, solar, or other mechanical piping with the following properties:
1. Base Material: Polycarbonate.
  2. Deck Base: 9 x 15-1/4 inch (228 x 387 mm).
  3. Pipe Clearance: Adjustable from the factory-set maximum height of 13-5/8 inches (346 mm) down to a minimum of 4-1/2 inches (114 mm).
  4. Maximum Load Weight: 186 pounds (84 kg) per pipestand.
  5. Pipe Rest: Self-lubricating polycarbonate resin roller, axle, and collar.
  6. Support All-Thread and Metal Parts: Stainless-steel.
  7. Support is optimally designed to carry up to a 4 inch pipe.
  8. Maximum pipe outside diameter (with insulation) is 5-1/2 inches (140 mm)
  9. Spacing: Horizontal support spacing per pipe specification, or horizontal pipe support intervals per the appropriate code or standard. Manufacturer's suggested spacing shall not exceed 10 foot (3 m) centers, as loading permits.
  10. If supporting insulated pipe, a shield or saddle shall be used.
- G. 5-RAH-8: Roller bearing pipe support for roof-mounted gas pipes, electrical conduit, solar, or other mechanical piping with the following properties:
1. Base Material: Polycarbonate.
  2. Deck Base: 9 x 15-1/4 inch (228 x 387 mm).
  3. Pipe Clearance: Adjustable from the factory-set maximum height of 8 inches (203 mm) down to a minimum of 3-3/4 inches (95 mm).
  4. Maximum Load Weight: 335 pounds (152 kg) per pipestand.
  5. Pipe Rest: Self-lubricating polycarbonate resin roller.
  6. Support All-Thread, Axle, and Metal Parts: Stainless-steel.
  7. Support is optimally designed to carry up to a 5 inch pipe.
  8. Maximum pipe outside diameter (with insulation) is 8-1/2 inches (216 mm).
  9. Spacing: Horizontal support spacing per pipe specification, or horizontal pipe support intervals per the appropriate code or standard. Manufacturer's suggested spacing shall not exceed 10 foot (3 m) centers, as loading permits.

10. If supporting insulated pipe, a shield or saddle shall be used.
- H. 5-RAH-12: Roller bearing pipe support for roof-mounted gas pipes, electrical conduit, solar, or other mechanical piping with the following properties:
1. Base Material: Polycarbonate.
  2. Deck Base: 9 x 15-1/4 inch (228 x 387 mm).
  3. Pipe Clearance: Adjustable from the factory-set maximum height of 12 inches (305 mm) down to a minimum of 3-3/4 inches (895 mm).
  4. Maximum Load Weight: 335 pounds (152 kg) per pipestand.
  5. Pipe Rest: Self-lubricating polycarbonate resin roller.
  6. Support All-Thread, Axle, and Metal Parts: Stainless-steel.
  7. Support is optimally designed to carry up to a 5 inch pipe.
  8. Maximum pipe outside diameter (with insulation) is 8-1/2 inches (216 mm).
  9. Spacing: Horizontal support spacing per pipe specification, or horizontal pipe support intervals per the appropriate code or standard. Manufacturer's suggested spacing shall not exceed 10 foot (3 m) centers, as loading permits.
  10. If supporting insulated pipe, a shield or saddle shall be used.
- I. 6-RAH-8: Roller bearing pipe support for roof-mounted gas pipes, electrical conduit, solar, or other mechanical piping with the following properties:
1. Base Material: Polycarbonate.
    - a. Deck Base: 16 x 18 inch (406 x 457 mm).
    - b. Pipe Clearance: Adjustable from the factory-set maximum height of 8 inches (203 mm) down to a minimum of 4-3/8 inches (111 mm).
    - c. Maximum Load Weight: 578 pounds (262 kg) per pipestand.
  2. Base Material: Type 304 Stainless-steel. (Model 6-RAH-8 SS)
    - a. Deck Base: 12 x 16 inch (305 x 406 mm).
    - b. Pipe Clearance: Adjustable from the factory-set maximum height of 8 inches (203 mm) down to a minimum of 2-7/8 inches (73 mm).
    - c. Maximum Load Weight: 524 pounds (238 kg) per pipestand.
  3. Pipe Rest: Self-lubricating polycarbonate resin roller.
  4. Support All-Thread, Axle, and Metal Parts: Stainless-steel.
  5. Support is optimally designed to carry up to a 6 inch pipe.
  6. Maximum pipe outside diameter (with insulation) is 8-1/2 inches (216 mm).
  7. Spacing: Horizontal support spacing per pipe specification, or horizontal pipe support intervals per the appropriate code or standard. Manufacturer's suggested spacing shall not exceed 10 foot (3 m) centers, as loading permits.
  8. If supporting insulated pipe, a shield or saddle shall be used.
- J. 6-RAH-12 - Dynamic: Roller bearing pipe support for roof-mounted gas pipes, electrical conduit, solar, or other mechanical piping with the following properties:
1. Base Material: Polycarbonate.
  2. Base Material: Polycarbonate.

- a. Deck Base: 16 x 18 inch (406 x 457 mm).
  - b. Pipe Clearance: Adjustable from the factory-set maximum height of 12 inches (305 mm) down to a minimum of 4-3/8 inches (111 mm).
  - c. Maximum Load Weight: 578 pounds (262.18 kg) per pipestand.
3. Base Material: Type 304 Stainless-steel. (Model 6-RAH-12 SS)
    - a. Deck Base: 12 x 16 inch (305 x 406 mm).
    - b. Pipe Clearance: Adjustable from the factory-set maximum height of 12 inches (305 mm) down to a minimum of 2-7/8 inches (73 mm).
    - c. Maximum Load Weight: 524 pounds (238 kg) per pipestand.
  4. Pipe Rest: Self-lubricating polycarbonate resin roller.
  5. Support All-Thread, Axle, and Metal Brackets: Stainless-steel.
  6. Support is optimally designed to carry up to a 6 inch pipe.
  7. Maximum pipe outside diameter (with insulation) is 8-1/2 inches (216 mm).
  8. Spacing: Horizontal support spacing per pipe specification or horizontal pipe support intervals per the appropriate code or standard. Manufacturer's suggested spacing shall not exceed 10 foot (3 m) centers, as loading permits.
  9. If supporting insulated pipe, a shield or saddle shall be used.
- K. 10-RAH-8 - Dynamic: Roller bearing pipe support for roof-mounted gas pipes, electrical conduit, solar, or other mechanical piping with the following properties:
1. Base Material: Polycarbonate.
  2. Deck Base: 19 x 23 inch (482 x 584 mm).
  3. Pipe Clearance: Adjustable from the factory-set maximum height of 8 inches (203 mm) down to a minimum of 6 inches (152 mm).
  4. Maximum Load Weight: 960 pounds (435 kg) per pipestand.
  5. Roller Material: Composite rubber.
  6. Support All-Thread, Axle and hardware: Stainless-steel.
  7. Support is optimally designed to carry up to a 10 inch pipe.
  8. Maximum pipe outside diameter (with insulation) is 13 inches (330 mm).
  9. Spacing: Horizontal support spacing per pipe specification or horizontal pipe support intervals per the appropriate code or standard. Manufacturer's suggested spacing shall not exceed 10 foot (3 m) centers, as loading permits.
  10. If supporting insulated pipe, a shield or saddle shall be used.
- L. 10-RAH-18: Roller bearing pipe support for roof-mounted gas pipes, electrical conduit, solar, or other mechanical piping with the following properties:
1. Base Material: Polycarbonate.
  2. Deck Base: 19 x 23 inch (482 x 584 mm).
  3. Pipe Clearance: Adjustable from the factory-set maximum height of 17-3/4 inches (451 mm) down to a minimum of 6 inches (152 mm).
  4. Maximum Load Weight: 803 pounds (364 kg) per pipestand.
  5. Roller Material: Composite rubber.



6. Support All-Thread, Axle and hardware: Stainless-steel.
7. Support is optimally designed to carry up to a 10 inch pipe.
8. Maximum pipe outside diameter (with insulation) is 13 inches (330 mm).
9. Spacing: Horizontal support spacing per pipe specification or horizontal pipe support intervals per the appropriate code or standard. Manufacturer's suggested spacing shall not exceed 10 foot (3 m) centers, as loading permits.
10. If supporting insulated pipe, a shield or saddle shall be used.

## 2.5 STRUT SUPPORT SERIES

- A. 8-Base Strut-2: Pipe support with strut used to support roof-mounted electrical conduit, solar piping, solar racking, gas piping, cable trays, or other mechanical equipment with the following properties:
  1. Base Material: Polycarbonate.
  2. Deck Base: 7-1/2 x 10 inch (190 x 254 mm).
  3. Pipe Clearance: Fixed 2-1/2 inches (64 mm).
  4. Maximum Load Weight: 172 pounds (78 kg) per pipestand.
  5. Pipe Rest: 8 inch (203 mm) hot-dipped galvanized steel struts connected with hot-dipped galvanized bolts to the base.
  6. Spacing: Horizontal support spacing per pipe specification, or horizontal pipe support intervals per the appropriate code or standard. Manufacturer's suggested spacing shall not exceed 10 foot (3 m) centers, as loading permits.
  7. If supporting insulated pipe, a shield or saddle shall be used.
  8. Strut clamps may be used to attach components to the support.
- B. 8-Base Strut-5: Pipe support with strut used to support roof-mounted electrical conduit, solar piping, solar racking, gas piping, cable trays, or other mechanical equipment with the following properties:
  1. Base Material: Polycarbonate.
  2. Deck Base: 7-1/2 x 10 inch (190 x 254 mm).
  3. Pipe Clearance: Adjustable from the factory-set maximum height of 5-3/8 inches (137 mm) down to a minimum of 3-1/2 inches (89 mm).
  4. Maximum Load Weight: 172 pounds (78 kg) per pipestand.
  5. Pipe Rest: 8 inch (203 mm) hot-dipped galvanized steel struts connected with stainless-steel all thread to the base.
  6. Spacing: Horizontal support spacing per pipe specification, or horizontal pipe support intervals per the appropriate code or standard. Manufacturer's suggested spacing shall not exceed 10 foot (3 m) centers, as loading permits.
  7. If supporting insulated pipe, a shield or saddle shall be used.
  8. Strut clamps may be used to attach components to the support.
- C. 8-Base Strut-8: Pipe support with strut used to support roof-mounted electrical conduit, solar piping, solar racking, gas piping, cable trays, or other mechanical equipment with the following properties:
  1. Base Material: Polycarbonate.

- a. Deck Base: 7-1/2 x 10 inch (190 x 254 mm).
  - b. Pipe Clearance: Adjustable from the factory-set maximum height of 8-7/8 inches (225 mm) down to a minimum of 3-1/2 inches (89 mm).
  - c. Maximum Load Weight: 172 pounds (78 kg) per pipestand.
2. Base Material: Type 304 Stainless-steel. (Model 8-Base Strut-8 SS)
    - a. Deck Base: 12 x 16 inch (305 x 406 mm).
    - b. Pipe Clearance: Adjustable from the factory-set maximum height of 8-7/8 inches (225 mm) down to a minimum of 3-1/8 inches (79 mm).
    - c. Maximum Load Weight: 419 pounds (190 kg) per pipestand.
  3. Pipe Rest: 8 inch (203 mm) hot-dipped galvanized steel struts connected with stainless-steel all thread to the base.
  4. Spacing: Horizontal support spacing per pipe specification, or horizontal pipe support intervals per the appropriate code or standard. Manufacturer's suggested spacing shall not exceed 10 foot (3 m) centers, as loading permits.
  5. If supporting insulated pipe, a shield or saddle shall be used.
  6. Strut clamps may be used to attach components to the support.
- D. 8-Base Strut-12: Pipe support with strut used to support roof-mounted electrical conduit, solar piping, solar racking, gas piping, cable trays, or other mechanical equipment with the following properties:
1. Base Material: Polycarbonate.
    - a. Deck Base: 7-1/2 x 10 inch (190 x 254 mm).
    - b. Pipe Clearance: Adjustable from the factory-set maximum height of 12-7/8 inches (327 mm) down to a minimum of 3-1/2 inches (89 mm).
    - c. Maximum Load Weight: 172 pounds (78 kg) per pipestand.
  2. Base Material: Type 304 Stainless-steel. (Model 8-Base Strut-12 SS)
    - a. Deck Base: 12 x 16 inch (305 x 406 mm).
    - b. Pipe Clearance: Adjustable from the factory-set maximum height of 12-7/8 inches (327 mm) down to a minimum of 3-1/8 inches (79 mm).
    - c. Maximum Load Weight: 186 pounds (84 kg) per pipestand.
  3. Pipe Rest: 8 inch (203 mm) hot-dipped galvanized steel struts connected with stainless-steel all thread to the base.
  4. Spacing: Horizontal support spacing per pipe specification, or horizontal pipe support intervals per the appropriate code or standard. Manufacturer's suggested spacing shall not exceed 10 foot (3 m) centers, as loading permits.
  5. If supporting insulated pipe, a shield or saddle shall be used.
  6. Strut clamps may be used to attach components to the support.
- E. 12-Base Strut-8: Strut pipe support system for ganging roof-mounted electrical conduit, solar piping, solar racking, gas piping, cable trays, or other mechanical equipment with the following properties:
1. Base Material: Polycarbonate.
    - a. Deck Base: 9 x 15-1/4 inch (228 x 387 mm).
    - b. Pipe Clearance: Adjustable from the factory-set maximum height of 9-1/4

- inches (235 mm) down to a minimum of 4-1/4 inches (108 mm).
- c. Maximum Load Weight on Base: 335 pounds (152 kg) per pipestand.
- 2. Base Material: Stainless-steel. (Model 12-Base Strut-8 SS)
  - a. Deck Base: 12 x 16 inch (305 x 406 mm).
  - b. Pipe Clearance: Adjustable from the factory-set maximum height of 9-1/4 inches (235 mm) down to a minimum of 3-1/4 inches (83 mm).
  - c. Maximum Load Weight on Base: 524 pounds (238 kg) per pipestand.
- 3. Pipe Rest: 12 inch (305 mm) Hot-dipped galvanized steel struts connected with stainless-steel all thread to the base.
- 4. Spacing: Horizontal support spacing per pipe specification, or horizontal pipe support intervals per the appropriate code or standard. Manufacturer's suggested spacing shall not exceed 10 foot (3 m) centers, as loading permits.
- 5. If supporting insulated pipe, a shield or saddle shall be used.
- 6. Strut clamps may be used to attach components to the support.
- F. 12-Base Strut-12: Strut pipe support system for ganging roof-mounted electrical conduit, solar piping, solar racking, gas piping, cable trays, or other mechanical equipment with the following properties:
  - 1. Base Material: Polycarbonate.
    - a. Deck Base: 9 x 15-1/4 inch (228 x 387 mm).
    - b. Pipe Clearance: Adjustable from the factory-set maximum height of 13-1/4 inches (337 mm) down to a minimum of 4-1/4 inches (108 mm).
    - c. Maximum Load Weight: 335 pounds (152 kg) per pipestand.
  - 2. Base Material: Stainless-steel. (Model 12-Base Strut-12 SS)
    - a. Deck Base: 12 x 16 inch (305 x 406 mm).
    - b. Pipe Clearance: Adjustable from the factory-set maximum height of 13-1/4 inches (337 mm) down to a minimum of 3-1/4 inches (83 mm).
    - c. Maximum Load Weight on Base: 524 pounds (238 kg) per pipestand.
  - 3. Pipe Rest: 12 inch (305 mm) Hot-dipped galvanized steel struts connected with stainless-steel all thread to the base.
  - 4. Spacing: Horizontal support spacing per pipe specification, or horizontal pipe support intervals per the appropriate code or standard. Manufacturer's suggested spacing shall not exceed 10 foot (3 m) centers, as loading permits.
  - 5. If supporting insulated pipe, a shield or saddle shall be used.
  - 6. Strut clamps may be used to attach components to the support.
- G. 16-Base Strut-8: Strut pipe support system for ganging roof-mounted electrical conduit, solar piping, solar racking, gas piping, cable trays, or other mechanical equipment with the following properties:
  - 1. Base Material: Polycarbonate.
  - 2. Deck Base: 16 x 18 inch (406 x 457 mm).
  - 3. Pipe Clearance: Adjustable from the factory-set maximum height of 9-1/4 inches (235 mm) down to a minimum of 4-3/4 inches (114 mm).

4. Maximum Load Weight: 578 pounds (262 kg) per pipestand.
  5. Pipe Rest: 16 inch (406 mm) Hot-dipped galvanized steel struts connected with stainless-steel all thread to the base.
  6. Spacing: Horizontal support spacing per pipe specification, or horizontal pipe support intervals per the appropriate code or standard. Manufacturer's suggested spacing shall not exceed 10 foot (3 m) centers, as loading permits.
  7. If supporting insulated pipe, a shield or saddle shall be used.
  8. Strut clamps may be used to attach components to the support.
- H. 16-Base Strut-12: Strut pipe support system for ganging roof-mounted electrical conduit, solar piping, solar racking, gas piping, cable trays, or other mechanical equipment with the following properties:
1. Base Material: Polycarbonate.
  2. Deck Base: 16 x 18 inch (406 x 457 mm).
  3. Pipe Clearance: Adjustable from the factory-set maximum height of 13-1/4 inches (337 mm) down to a minimum of 4-3/4 inches (120 mm).
  4. Maximum Load Weight: 578 pounds (262 kg) per pipestand.
  5. Pipe Rest: 16 inch (406 mm) Hot-dipped galvanized steel struts connected with stainless-steel all thread to the base.
  6. Spacing: Horizontal support spacing per pipe specification, or horizontal pipe support intervals per the appropriate code or standard. Manufacturer's suggested spacing shall not exceed 10 foot (3 m) centers, as loading permits.
  7. If supporting insulated pipe, a shield or saddle shall be used.
  8. Strut clamps may be used to attach components to the support.
- I. 20-Base Strut-4: Strut pipe support system for ganging roof-mounted electrical conduit, solar piping, solar racking, gas piping, cable trays, or other mechanical equipment with the following properties:
1. Base Material: Polycarbonate.
  2. Deck Base: 19 x 23 inch (483 x 584 mm).
  3. Pipe Clearance: Fixed 4-1/8 inches (105 mm).
  4. Maximum Load Weight: 960 pounds (435 kg) per pipestand.
  5. Pipe Rest: 20 inch (508 mm) Hot-dipped galvanized steel struts connected with hot-dipped galvanized bolt to the base.
  6. Spacing: Horizontal support spacing per pipe specification, or horizontal pipe support intervals per the appropriate code or standard. Manufacturer's suggested spacing shall not exceed 10 foot (3 m) centers, as loading permits.
  7. If supporting insulated pipe, a shield or saddle shall be used.
  8. Strut clamps may be used to attach components to the support.
- J. 20-Base Strut-8 - Elevate: Strut pipe support system for ganging roof-mounted electrical conduit, solar piping, solar racking, gas piping, cable trays, or other mechanical equipment with the following properties:
1. Base Material: Polycarbonate.
  2. Deck Base: 19 x 23 inch (483 x 584 mm).



3. Pipe Clearance: Adjustable from the factory-set maximum height of 9-1/2 inches (241 mm) down to a minimum of 5-1/2 inches (140 mm).
  4. Maximum Load Weight: 960 pounds (435 kg) per pipestand.
  5. Pipe Rest: 20 inch (508 mm) Hot-dipped galvanized steel struts connected with stainless-steel all thread to the base.
  6. Spacing: Horizontal support spacing per pipe specification, or horizontal pipe support intervals per the appropriate code or standard. Manufacturer's suggested spacing shall not exceed 10 foot (3 m) centers, as loading permits.
  7. If supporting insulated pipe, a shield or saddle shall be used.
  8. Strut clamps may be used to attach components to the support.
- K. 20-Base Strut-18 - Elevate: Strut pipe support system for ganging roof-mounted electrical conduit, solar piping, solar racking, gas piping, cable trays, or other mechanical equipment with the following properties:
1. Base Material: Polycarbonate.
  2. Deck Base: 19 x 23 inch (483 x 584 mm).
  3. Pipe Clearance: Adjustable from the factory-set maximum height of 19 inches (483 mm) down to a minimum of 5-1/2 inches (140 mm).
  4. Maximum Load Weight: 717 pounds (325 kg) per pipestand.
  5. Pipe Rest: 20 inch (508 mm) Hot-dipped galvanized steel struts connected with stainless-steel all thread to the base.
  6. Spacing: Horizontal support spacing per pipe specification, or horizontal pipe support intervals per the appropriate code or standard. Manufacturer's suggested spacing shall not exceed 10 foot (3 m) centers, as loading permits.
  7. If supporting insulated pipe, a shield or saddle shall be used.
  8. Strut clamps may be used to attach components to the support.
- L. 24-Base Strut-5: Strut pipe support system for ganging roof-mounted electrical conduit, solar piping, solar racking, gas piping, cable trays, or other mechanical equipment with the following properties:
1. Base Material: Polycarbonates.
  2. Deck Base: Two 7-1/2 x 10 inch (190 x 254 mm) bases.
  3. Pipe Clearance: Adjustable from the factory-set maximum height of 6-1/8 inches (156 mm) down to a minimum of 4-1/8 inches (105 mm).
  4. Maximum Allowable Uniform Load: 172.5 pounds per foot (256 kg/m).
  5. Pipe Rest: 24 inch (610 mm) Hot-dipped galvanized steel struts connected with stainless-steel all thread to the base.
  6. Spacing: Horizontal support spacing per pipe specification, or horizontal pipe support intervals per the appropriate code or standard. Manufacturer's suggested spacing shall not exceed 10 foot (3 m) centers, as loading permits.
  7. If supporting insulated pipe, a shield or saddle shall be used.
  8. Strut clamps may be used to attach components to the support.
- M. 36-Base Strut-5: Strut pipe support system for ganging roof-mounted electrical conduit, solar piping, solar racking, gas piping, cable trays, or other mechanical equipment with the following properties:

1. Base Material: Polycarbonate.
  2. Deck Base: Three 7-1/2 x 10 inch (190 x 254 mm) bases.
  3. Pipe Clearance: Adjustable from the factory-set maximum height of 6-1/8 inches (156 mm) down to a minimum of 4-1/8 inches (105 mm).
  4. Maximum Allowable Uniform Load: 172.5 pounds per foot (256 kg/m).
  5. Pipe Rest: 36 inch (914 mm) Hot-dipped galvanized steel struts connected with stainless-steel all thread to the base.
  6. Spacing: Horizontal support spacing per pipe specification, or horizontal pipe support intervals per the appropriate code or standard. Manufacturer's suggested spacing shall not exceed 10 foot (3 m) centers, as loading permits.
  7. If supporting insulated pipe, a shield or saddle shall be used.
  8. Strut clamps may be used to attach components to the support.
- N. 48-Base Strut-5: Strut pipe support system for ganging roof-mounted electrical conduit, solar piping, solar racking, gas piping, cable trays, or other mechanical equipment with the following properties:
1. Base Material: Polycarbonate.
  2. Deck Base: Four 7-1/2 x 10 inch (190 x 254 mm) bases.
  3. Pipe Clearance: Adjustable from the factory-set maximum height of 6-1/8 inches (156 mm) down to a minimum of 4-1/8 inches (105 mm).
  4. Maximum Allowable Uniform Load: 172.5 pounds per foot (256 kg/m).
  5. Pipe Rest: 48 inch (1219.2 mm) Hot-dipped galvanized steel struts connected with stainless-steel all thread to the base.
  6. Spacing: Horizontal support spacing per pipe specification, or horizontal pipe support intervals per the appropriate code or standard. Manufacturer's suggested spacing shall not exceed 10 foot (3 m) centers, as loading permits.
  7. If supporting insulated pipe, a shield or saddle shall be used.
  8. Strut clamps may be used to attach components to the support.

## 2.6 CUSTOM HANGER SUPPORT SERIES

- A. 6H Model Hanger Support: A versatile, custom product able to support a single pipe or multiple pipes at varying heights above the roof for maximum efficiency and cost savings. The system is designed for various pipe sizes and configurations. The frame structure consists of two load-distributing bases with vertical strut legs and a horizontal strut header. Supports sizes are to be determined for project specific requirements and allow for a range of vertical adjustability. Horizontal cross-bracing between adjacent frames may be required. Support is to include appropriate hanger type as specified below. Provide rooftop pipe layout drawings for manufacturer's use and the following:
1. Deck Bases:
    - a. Polycarbonate, 9 x 15-1/4 inch (229 x 387 mm).
    - b. Stainless-steel, 8 x 14 inch (203 x 356 mm).
    - c. Hot-dipped galvanized steel, 8 x 14 inch (203 x 356 mm).
  2. Type of Pipe Being Supported: \_\_\_\_\_.
  3. Pipe Contents: \_\_\_\_\_.

4. Centerline Distance between Adjacent Pipes for Multiple Pipe Supports: \_\_\_\_\_.
  5. Minimum / Maximum Clearance Above Roof: \_\_\_\_\_.
  6. Pipe Insulation Thickness: \_\_\_\_\_.
  7. Total Length of Pipe Run: \_\_\_\_\_.
  8. Quantity of Supports Required: \_\_\_\_\_.
  9. Hanger Type:
    - a. Clevis hanger.
    - b. Roller hanger.
    - c. Roller chair.
    - d. Trapeze hanger.
  10. If supporting insulated pipe, a shield or saddle shall be used at each hanger location.
- B. 8H Model Hanger Support:** A versatile, custom product able to support a single pipe or multiple pipes at varying heights above the roof for maximum efficiency and cost savings. The system is designed for various pipe sizes and configurations. The frame structure consists of two load-distributing bases with vertical strut legs and a horizontal strut header. Support sizes are to be determined for project specific requirements and allow for a range of vertical adjustability. Horizontal cross-bracing between adjacent frames may be required. Support is to include appropriate hanger type as specified below. Provide rooftop pipe layout drawings for manufacturer's use and the following:
1. Deck Bases:
    - a. Polycarbonate, 16 x 18 inch (406 x 457 mm).
    - b. Stainless-steel, 12 x 16 inch (305 x 406 mm).
    - c. Hot-dipped galvanized steel, 12 x 16 inch (305 x 406 mm).
  2. Type of Pipe Being Supported: \_\_\_\_\_.
  3. Pipe Contents: \_\_\_\_\_.
  4. Centerline Distance between Adjacent Pipes for Multiple Pipe Supports: \_\_\_\_\_.
  5. Minimum / Maximum Clearance Above Roof: \_\_\_\_\_.
  6. Pipe Insulation Thickness: \_\_\_\_\_.
  7. Total length of Pipe Run: \_\_\_\_\_.
  8. Quantity of Supports Required: \_\_\_\_\_.
  9. Hanger Type:
    - a. Clevis hanger.
    - b. Roller hanger.
    - c. Roller chair.
    - d. Trapeze hanger.
  10. If supporting insulated pipe, a shield or saddle shall be used.
- C. 10H Model Hanger Support:** A versatile, custom product able to support a single pipe or multiple pipes at varying heights above the roof for maximum efficiency and cost savings. The system is designed for various pipe sizes and configurations. The frame structure consists of two load-distributing bases with vertical strut legs and a horizontal strut header.

Support sizes are to be determined for project specific requirements and allow for a range of vertical adjustability. Horizontal cross-bracing between adjacent frames may be required. Support is to include appropriate hanger type as specified below. Provide rooftop pipe layout drawings for manufacturer's use and the following:

1. Deck Bases: Polycarbonate, 19 x 23 inch (483 x 584 mm).
  2. Type of Pipe Being Supported: \_\_\_\_\_.
  3. Pipe Contents: \_\_\_\_\_.
  4. Centerline Distance between Adjacent Pipes for Multiple Pipe Supports: \_\_\_\_\_.
  5. Minimum / Maximum Clearance Above Roof: \_\_\_\_\_.
  6. Pipe Insulation Thickness: \_\_\_\_\_.
  7. Total length of Pipe Run: \_\_\_\_\_.
  8. Quantity of Supports Required: \_\_\_\_\_.
  9. Hanger Type:
    - a. Clevis hanger.
    - b. Roller hanger.
    - c. Roller chair.
    - d. Trapeze hanger.
  10. If supporting insulated pipe, a shield or saddle shall be used.
- D. Custom Stanchioned Model Supports: For rooftop-mounted pipe subject to design requirements for wind and seismic forces, the supports from the above categories with Stanchioned Supports placed strategically on the roof will provide a code compliant solution.
1. Type of Pipe Being Supported: \_\_\_\_\_.
  2. Pipe Contents: \_\_\_\_\_.
  3. Centerline Distance between Adjacent Pipes for Multiple Pipe Supports: \_\_\_\_\_.
  4. Minimum/Maximum Clearance Above Roof: \_\_\_\_\_.
  5. Pipe Insulation Thickness: \_\_\_\_\_.
  6. Total Length of Pipe Run: \_\_\_\_\_.
  7. Structural Design Criteria in accordance with Structural Documents.
  8. Wind and Seismic Design Criteria:
    - a. Adopted Building Code: \_\_\_\_\_.
    - b. Building Risk/Occupancy Category: \_\_\_\_\_.
    - c. Wind Design Criteria:
      - 1) Mean Roof Height: \_\_\_\_\_
      - 2) Basic Wind Speed: \_\_\_\_\_ (3 Second Gust).
      - 3) Exposure Category: \_\_\_\_\_
    - d. Seismic Design Criteria:
      - 1) Seismic Design Category: \_\_\_\_\_
      - 2) Design Short Period MCE Spectral Response acceleration,  $S_{DS}$ : \_\_\_\_\_



3) Seismic Component Importance Factor,  $I_e$ : \_\_\_\_\_

9. Appliances and supports that are exposed to wind shall be designed and installed to resist wind pressures determined in accordance with ASCE 7 chapter 29.
10. When earthquake loads are applicable in accordance with ASCE 7 chapter 13, mechanical systems and supports shall be designed and installed accordingly.
11. The design requirements for mechanical/electrical components, supports and attachments shall be supported by one of the following methods:
  - a. Project-specific design and documentation submitted for approval to the authority having jurisdiction after review and acceptance by a registered design professional.
  - b. Submittal of manufacturer's certification that the component is qualified by an independent third party via either analysis or testing in accordance with industry standards.
12. If supporting insulated pipe, a shield or saddle shall be used.

## 2.7 CUSTOM DUCT AND CABLE TRAY SUPPORT SERIES

- A. 6DS Model Duct and Cable Tray Support: A versatile, custom product designed for single or multiple duct supports and cable trays at varying heights above the roof and varying widths for maximum efficiency and cost savings. The system is designed to project-specific requirements. The frame structure consists of two load-distributing bases with vertical strut legs and a horizontal strut header. Supports are designed with a range of vertical adjustability. Horizontal cross-bracing between adjacent frames may be required. Provide rooftop duct layout drawings for manufacturer's use and the following:
  1. Deck Bases: Polycarbonate, 9 x 15-1/4 inch (229 x 387 mm).
  2. Deck Bases: Stainless-steel, 8 x 14 inch (203 x 356 mm).
  3. Deck Bases: Hot-dipped galvanized steel, 8 x 14 inch (203 x 357 mm).
  4. Duct Dimensions: \_\_\_\_\_. (Width x Height)
  5. Duct Material: \_\_\_\_ gauge thickness.
  6. Minimum / Maximum Clearance Above Roof: \_\_\_\_\_.
  7. Duct Insulation Thickness: \_\_\_\_\_ (Exterior Insulation).
  8. Maximum Outside Dimension: \_\_\_\_\_ (Width x Height).
  9. Total Length of Duct Run: \_\_\_\_\_.
  10. Quantity of Supports Required: \_\_\_\_\_.
  11. Provide additional header bar to enclose equipment being supported.
- B. 8DS Model Duct and Cable Tray Support: A versatile, custom product designed for single or multiple duct supports and cable trays at varying heights above the roof and varying widths for maximum efficiency and cost savings. The system is designed to project specific requirements. The frame structure consists of two load-distributing bases with vertical strut legs and a horizontal strut header. Supports are designed with a range of vertical adjustability. Horizontal cross-bracing between adjacent frames may be required. Provide rooftop duct layout drawings for manufacturer's use and the following:
  1. Deck Bases: Polycarbonate, 16 x 18 inch (406 x 457 mm).
  2. Deck Bases: Stainless-steel, 12 x 16 inch (305 x 406 mm).
  3. Deck Bases: Hot-dipped galvanized steel, 12 x 16 inch (305 x 406 mm).

4. Duct Dimensions: \_\_\_\_\_ (Width x Height)
  5. Duct Material: \_\_\_\_ gauge thickness.
  6. Minimum/Maximum Clearance Above Roof: \_\_\_\_\_.
  7. Duct Insulation Thickness: \_\_\_\_\_ (Exterior Insulation).
  8. Maximum Outside Dimension: \_\_\_\_\_ (Width x Height).
  9. Total Length of Duct Run: \_\_\_\_\_.
  10. Quantity of Supports Required: \_\_\_\_\_.
  11. Provide additional header bar to enclose equipment being supported.
- C. 10DS Model Duct and Cable Tray Support: A versatile, custom product designed for single or multiple duct supports and cable trays at varying heights above the roof and varying widths for maximum efficiency and cost savings. Th system is designed to project specific requirements. The frame structure consists of two load-distributing bases with vertical strut legs and a horizontal strut header. Supports are designed with a range of vertical adjustability. Horizontal cross-bracing between adjacent frames may be required. Provide rooftop duct layout drawings for manufacturer's use and the following:
1. Deck Bases: Polycarbonate, 19 x 23 inch (483 x 584 mm).
  2. Duct Dimensions: \_\_\_\_\_ (Width x Height).
  3. Duct Material: \_\_\_\_ gauge thickness.
  4. Minimum / Maximum Clearance Above Roof: \_\_\_\_\_.
  5. Duct Insulation Thickness: \_\_\_\_\_ (External Insulation).
  6. Maximum Outside Dimension: \_\_\_\_\_ (Width x Height).
  7. Total Length of Duct Run: \_\_\_\_\_.
  8. Quantity of Supports Required: \_\_\_\_\_.
  9. Provide additional header bar to enclose equipment being supported.
- D. Custom Stanchioned Model Supports: For rooftop-mounted pipe subject to design requirements for wind and seismic forces, the supports from the above categories with Stanchioned Supports placed strategically on the roof will provide a code compliant solution.
1. Duct Dimensions: \_\_\_\_\_ (Width x Height).
  2. Duct Material: \_\_\_\_ gauge thickness.
  3. Minimum / Maximum Clearance Above Roof: \_\_\_\_\_.
  4. Duct Insulation Thickness: \_\_\_\_\_ (Exterior Insulation).
  5. Maximum Outside Dimension: \_\_\_\_\_ (Width x Height).
  6. Total Length of Duct Run: \_\_\_\_\_.
  7. Structural Design Criteria in accordance with Structural Documents
  8. Wind and Seismic Design Criteria:
    - a. Adopted Building Code: \_\_\_\_\_.
    - b. Building Risk/Occupancy Category: \_\_\_\_\_.
    - c. Wind Design Criteria:
      - 1) Mean Roof Height: \_\_\_\_\_.
      - 2) Basic Wind Speed: \_\_\_\_\_ (3 Second Gust).

- 3) Exposure Category:\_\_\_\_\_.
- d. Seismic Design Criteria:
  - 1) Seismic Design Category:\_\_\_\_\_
  - 2) Design Short Period MCE Spectral Response acceleration,  $S_{DS}$ :\_\_\_\_\_
  - 3) Seismic Component Importance Factor,  $I_E$ :\_\_\_\_\_
9. Appliances and supports that are exposed to wind shall be designed and installed to resist wind pressures determined in accordance with ASCE 7 chapter 29.
10. When earthquake loads are applicable in accordance with ASCE 7 chapter 13, mechanical systems and supports shall be designed and installed accordingly.
11. The design requirements for mechanical/electrical components, supports and attachments shall be supported by one of the following methods:
  - a. Project-specific design and documentation submitted for approval to the authority having jurisdiction after review and acceptance by a registered design professional.
  - b. Submittal of manufacturer's certification that the component is qualified by an independent third party via either analysis or testing in accordance with industry standards.

## 2.8 MECHANICAL SUPPORTS

- A. LD Mechanical Supports: Custom product designed to elevate and support mechanical units, cabinets and other devices that allows the roof environment and mechanical pipe network to expand and contract with temperature changes. Support pan is adjustable in height, designed with slots to allow proper ventilation and moisture drainage, and the following:
  1. Deck Bases: Polycarbonate, four 7-1/2 x 10 inch (191 x 254 mm).
  2. Support Pan: An 11 ga. hot-dip galvanized pan with upturned edges and perforations in the center of the pan for ventilation and drainage.
  3. Pan size and height off the roof:
    - a. 20 x 36 inch (508 x 914 mm) with height adjustability from the factory-set maximum height of 8 inches (203 mm) down to a minimum of 2-1/2 inches (64 mm) above the roof.
    - b. 24 x 24 inch (610 x 610 mm) with height adjustability from the factory-set maximum height of 8 inches (203 mm) down to a minimum of 2-1/2 inches (64 mm) above the roof.
    - c. 30 x 30 inch (762 x 762 mm) with height adjustability from the factory-set maximum height of 8 inches (203 mm) down to a minimum of 2-1/2 inches (64 mm) above the roof.
    - d. 36 x 36 inch (914 x 914 mm) with height adjustability from the factory-set maximum height of 8 inches (203 mm) down to a minimum of 2-1/2 inches (64 mm) above the roof.
  4. Metal Components: Hot-dipped galvanized and stainless-steel.
  5. Mechanical Unit Weight: \_\_\_\_\_.
- B. 6-HD Mechanical Supports: Custom product designed to elevate and support mechanical units, cabinets and other devices that allows the roof environment and mechanical pipe network to expand and contract with temperature changes. Support is constructed to desired

height, width and length, and the following:

1. Deck Bases: Polycarbonate, 9 x 15-1/4 inch (229 x 387 mm).
  2. Deck Bases: Stainless-steel, 8 x 14 inch (203 x 356 mm).
  3. Deck Bases: Hot-dipped galvanized steel, 8 x 14 inch (203 x 356 mm).
  4. Platforms: 12 inch (305 mm) Punched Interlock Grating with anti-skid surface.
    - a. Platform Width: \_\_\_\_\_.
    - b. Platform Length: \_\_\_\_\_.
    - c. Minimum Clearance Above Roof: \_\_\_\_\_.
    - d. Mechanical Unit Weight: \_\_\_\_\_.
  5. Platforms: Bar grating.
    - a. Platform Width: \_\_\_\_\_.
    - b. Platform Length: \_\_\_\_\_.
    - c. Minimum Clearance Above Roof: \_\_\_\_\_.
    - d. Mechanical Unit Weight: \_\_\_\_\_.
  6. Rail style support: 1-5/8 inch (41 mm) strut rails.
    - a. Unit Width: \_\_\_\_\_.
    - b. Unit Length: \_\_\_\_\_.
    - c. Minimum Clearance Above Roof: \_\_\_\_\_.
    - d. Mechanical Unit Weight: \_\_\_\_\_.
- C. 8-HD Mechanical Supports: Custom product designed to elevate and support mechanical units, cabinets and other devices that allows the roof environment and mechanical pipe network to expand and contract with temperature changes. Support is constructed to desired height, width and length, and the following:
1. Deck Bases: Polycarbonate, 16 x 18 inch (406 x 457 mm).
  2. Deck Bases: Stainless-steel, 12 x 16 inch (305 x 406 mm).
  3. Deck Bases: Hot-dipped galvanized steel, 12 x 16 inch (305 x 406 mm).
  4. Platforms: 12 inch (305 mm) Punched Interlock Grating with anti-skid surface.
    - a. Platform Width: \_\_\_\_\_.
    - b. Platform Length: \_\_\_\_\_.
    - c. Minimum Clearance Above Roof: \_\_\_\_\_.
    - d. Mechanical Unit Weight: \_\_\_\_\_.
  5. Platforms: Bar grating.
    - a. Platform Width: \_\_\_\_\_.
    - b. Platform Length: \_\_\_\_\_.
    - c. Minimum Clearance Above Roof: \_\_\_\_\_.
    - d. Mechanical Unit Weight: \_\_\_\_\_.
  6. Rail style support: 1-5/8 inch (41 mm) strut rails.
    - a. Unit Width: \_\_\_\_\_.



- b. Unit Length: \_\_\_\_\_.
- c. Minimum Clearance Above Roof: \_\_\_\_\_.
- d. Mechanical Unit Weight: \_\_\_\_\_

D. Stanchioned Mechanical Support: For rooftop-mounted mechanical units, cabinets and other devices subject to design requirements for wind and seismic forces. Supports are to be designed to project specific criteria listed below:

1. Platform Width: \_\_\_\_\_.
2. Platform Length: \_\_\_\_\_.
3. Minimum/Maximum Clearance Above Roof: \_\_\_\_\_.
4. Mechanical Unit Dimensions: \_\_\_\_\_ long x \_\_\_\_\_ wide x \_\_\_\_\_ high.
5. Mechanical Unit Weight: \_\_\_\_\_.
6. Structural Design Criteria in accordance with Structural Documents
7. Wind and Seismic Design Criteria:
  - a. Adopted Building Code: \_\_\_\_\_
  - b. Building Risk/Occupancy Category: \_\_\_\_\_
  - c. Wind Design Criteria:
    - 1) Mean Roof Height: \_\_\_\_\_
    - 2) Basic Wind Speed: \_\_\_\_\_ (3 Second Gust).
    - 3) Exposure Category: \_\_\_\_\_
  - d. Seismic Design Criteria:
    - 1) Seismic Design Category: \_\_\_\_\_
    - 2) Design Short Period MCE Spectral Response acceleration,  $S_{DS}$ : \_\_\_\_\_
    - 3) Seismic Component Importance Factor,  $I_E$ : \_\_\_\_\_
8. Appliances and supports that are exposed to wind shall be designed and installed to resist wind pressures determined in accordance with ASCE 7 chapter 29.
9. When earthquake loads are applicable in accordance with ASCE 7 chapter 13, mechanical systems and supports shall be designed and installed accordingly.
10. The design requirements for mechanical/electrical components, supports and attachments shall be supported by one of the following methods:
  - a. Project-specific design and documentation submitted for approval to the authority having jurisdiction after review and acceptance by a registered design professional.
  - b. Submittal of manufacturer's certification that the component is qualified by an independent third party via either analysis or testing in accordance with industry standards.

## 2.9 SUREFOOT ACCESS PRODUCTS

- A. Crossover Bridges: Custom-designed to meet project specific requirements, OSHA 1910 Subpart D standards including handrails, and the following:
  1. Clearance Height Required: \_\_\_\_\_.

2. Clearance Length Required: \_\_\_\_\_.
3. Crossover Width Required: \_\_\_\_\_ (22 inches (559 mm) minimum).
4. Deck Bases: Polycarbonate, 16 x 18 inch (406 x 457 mm).
5. Deck Bases: Stainless-steel, 12 x 16 inch (305 x 406 mm).
6. Deck Bases: Hot-dipped galvanized steel, 12 x 16 inch (305 x 406 mm).
7. Metal Components: Hot-dipped galvanized steel.
8. Metal Components: Stainless-steel.
9. Walking Surfaces: 12 inch (305 mm) Punched Interlock Grating with anti-skid surface.
10. Walking Surfaces: Bar Grating with serrated surface.
11. Walking Surfaces: Fiberglass Grating.
12. Railings: Standard railings shall be provided on all stairways having 4 or more risers and platforms 4 feet (1.22 m) or more above adjacent level.
13. Toeboards: 4 inch (102 mm) Toeboards shall be provided whenever, beneath the open side:
  - a. A person can pass;
  - b. There is moving machinery;
  - c. Where falling material could create a hazard.
14. Structural Design Criteria in accordance with Structural Documents
15. Wind and Seismic Design Criteria:
  - a. Adopted Building Code:\_\_\_\_\_.
  - b. Building Risk/Occupancy Category:\_\_\_\_\_.
  - c. Wind Design Criteria:
    - 1) Mean Roof Height:\_\_\_\_\_.
    - 2) Basic Wind Speed:\_\_\_\_\_ (3 Second Gust).
    - 3) Exposure Category:\_\_\_\_\_.
  - d. Seismic Design Criteria:
    - 1) Seismic Design Category:\_\_\_\_\_.
    - 2) Design Short Period MCE Spectral Response acceleration,  $S_{DS}$ :\_\_\_\_\_.
    - 3) Seismic Component Importance Factor,  $I_E$ :\_\_\_\_\_.
16. Crossover structures that are exposed to wind shall be designed and installed to resist wind pressures determined in accordance with ASCE 7 chapter 29.
17. When earthquake loads are applicable in accordance with ASCE 7 chapter 13, crossover structures shall be designed and installed accordingly.
18. The design requirements for crossover structures, components, supports and attachments shall be supported by one of the following methods:
  - a. Project-specific design and documentation submitted for approval to the authority having jurisdiction after review and acceptance by a registered design professional.
  - b. Submittal of manufacturer's certification that the component is qualified by an

independent third party via either analysis or testing in accordance with industry standards.

- B. Crossover Ramps: Custom designed to meet project specific requirements OSHA 1910 Subpart D standards, and the following:
1. Clearance Height Required: \_\_\_\_\_.
  2. Clearance Length Required: \_\_\_\_\_.
  3. Ramp Width Required: \_\_\_\_\_ (22 inch (559 mm) minimum.)
  4. Deck Bases: Polycarbonate, 16 x 18 inch (406 x 457 mm).
  5. Deck Bases: Stainless-steel, 12 x 16 inch (305 x 406 mm).
  6. Deck Bases: Hot-dipped galvanized steel, 12 x 16 inch (305 x 406 mm).
  7. Metal Components: Hot-dipped galvanized steel.
  8. Metal Components: Stainless-steel.
  9. Walking Surfaces: 12 inch (305 mm) Punched Interlock Grating with anti-skid surface.
  10. Walking Surfaces: Bar grating with serrated surface.
  11. Walking Surfaces: Fiberglass Grating
  12. Railings: Standard railings shall be provided on all ramps and platforms 4 feet (1.22 m) or more above adjacent level.
  13. Toeboards: 4 inch (102 mm) Toeboards shall be provided whenever, beneath the open side:
    - a. A person can pass;
    - b. There is moving machinery;
    - c. Where falling material could create a hazard.
  14. Structural Design Criteria in accordance with Structural Documents
  15. Wind and Seismic Design Criteria:
    - a. Adopted Building Code:\_\_\_\_\_.
    - b. Building Risk/Occupancy Category:\_\_\_\_\_.
    - c. Wind Design Criteria:
      - 1) Mean Roof Height:\_\_\_\_\_.
      - 2) Basic Wind Speed:\_\_\_\_\_ (3 Second Gust).
      - 3) Exposure Category:\_\_\_\_\_.
    - d. Seismic Design Criteria:
      - 1) Seismic Design Category:\_\_\_\_\_
      - 2) Design Short Period MCE Spectral Response acceleration,  $S_{DS}$ :\_\_\_\_\_
      - 3) Seismic Component Importance Factor,  $I_E$ :\_\_\_\_\_
  16. Ramp structures that are exposed to wind shall be designed and installed to resist wind pressures determined in accordance with ASCE 7 chapter 29.
  17. When earthquake loads are applicable in accordance with ASCE 7 chapter 13, ramp structures shall be designed and installed accordingly.

18. The design requirements for ramp structures, components, supports and attachments shall be supported by one of the following methods:
  - a. Project-specific design and documentation submitted for approval to the authority having jurisdiction after review and acceptance by a registered design professional.
  - b. Submittal of manufacturer's certification that the component is qualified by an independent third party via either analysis or testing in accordance with industry standards.
  
- C. Service Platforms: Custom designed to meet project specific requirements OSHA 1910 Subpart D standards, and the following:
  1. Clearance Height Required: \_\_\_\_\_.
  2. Required Length of Platform: \_\_\_\_\_.
  3. Required Width of Platform: \_\_\_\_\_.
  4. Deck Bases: Polycarbonate, 16 x 18 inch (406 x 457 mm).
  5. Deck Bases: Stainless-steel, 12 x 16 inch (3058 x 406 mm).
  6. Deck Bases: Hot-dipped galvanized steel, 12 x 16 inch (305 x 406 mm).
  7. Metal Components: Hot-dipped galvanized steel.
  8. Metal Components: Stainless-steel.
  9. Walking Surfaces: 12 inch (305 mm) Punched Interlock Grating with anti-skid surface.
  10. Walking Surfaces: Bar grating with serrated surface.
  11. Walking Surfaces: Fiberglass Grating.
  12. Railings: Standard railings shall be provided on all ramps and platforms 4 feet (1.22 m) or more above adjacent level.
  13. Toeboards: 4 inch (102 mm) Toeboards shall be provided whenever, beneath the open side:
    - a. A person can pass;
    - b. There is moving machinery;
    - c. Where falling material could create a hazard.
  14. Structural Design Criteria in accordance with Structural Documents
  15. Wind and Seismic Design Criteria:
    - a. Adopted Building Code:\_\_\_\_\_.
    - b. Building Risk/Occupancy Category:\_\_\_\_\_.
    - c. Wind Design Criteria:
      - 1) Mean Roof Height:\_\_\_\_\_.
      - 2) Basic Wind Speed:\_\_\_\_\_ (3 Second Gust).
      - 3) Exposure Category:\_\_\_\_\_.
    - d. Seismic Design Criteria:
      - 1) Seismic Design Category:\_\_\_\_\_.
      - 2) Design Short Period MCE Spectral Response acceleration,  $S_{DS}$ :\_\_\_\_\_.



- 3) Seismic Component Importance Factor,  $I_E$ : \_\_\_\_\_.
16. Service Platform structures that are exposed to wind shall be designed and installed to resist wind pressures determined in accordance with ASCE 7 chapter 29.
  17. When earthquake loads are applicable in accordance with ASCE 7 chapter 13, Service Platform structures shall be designed and installed accordingly.
  18. The design requirements for Service Platform structures, components, supports and attachments shall be supported by one of the following methods:
    - a. Project-specific design and documentation submitted for approval to the authority having jurisdiction after review and acceptance by a registered design professional.
    - b. Submittal of manufacturer's certification that the component is qualified by an independent third party via either analysis or testing in accordance with industry standards.

## 2.10 ACCESSORIES

- A. Fitted Support Pads: Designed specifically to fit non-penetrating rooftop supports for additional protection of the rooftop envelope. Slip-resistant pads are heat molded with a small lip to hold the support pad and reduce movement on the rooftop. Holes in the pad save weight and allow for venting and drainage.
  1. Support Pad Material: 100 percent recycled rubber.
  2. Dimensions: Fitted 19 x 23 inch (483 x 584 mm).
  3. Dimensions: Fitted 16 x 18 inch (406 x 457 mm).
  4. Dimensions: Fitted 9 x 15 inch (230 x 381 mm).
  5. Dimensions: Fitted 7 x 10 inch (178 x 254 mm).
  6. Dimensions: 12 x 12 inch (304.8 x 305 mm).
  7. Dimensions: Custom size as recommended by the manufacturer.
- B. Flat Support Pads: Designed specifically to fit non-penetrating rooftop supports for additional protection of the rooftop envelope. Slip resistant pads are heat molded.
  1. Support Pad Material: 100 percent recycled rubber.
  2. Dimensions: 12 x 12 inch (305 x 305 mm).
  3. Dimensions: Custom size as recommended by the manufacturer.
- C. Pipe Guides: Designed to attach to pipe supports to allow pipe to be installed or removed from pipe stands. Pipe guides ship separately for site installation, allowing room for expansion and contraction as recommended by the manufacturer.
  1. Size: 1.5.
  2. Size: 3-R-2.
  3. Size: 3-R-4.
  4. Size: 3-RAH-3.
  5. Size: 4-RAH-4.
  6. Size: 5-RAH-5.
  7. Size: 6-RAH-6.
  8. Size: 10-RAH-10

9. Size: Custom size per job specific requirements.
- D. Spacers: Polycarbonate structure with gently rounded base, drainage holes and alignment pins that attached to other components to increase height.
  1. Size: 1.5.
  2. Size: 3-R.
- E. 3-R Riser Brackets (Pairs): Designed to be inserted into Model 3-R-2 to raise the roller height clearance by 2 inches (51 mm). Sold as a pair to be inserted into 3-R-2 roof supports.
  1. Installation: Field installed.
  2. Installation: Factory installed in the 3-R-4 support.
- F. Rollers: Heavy duty support roller of polycarbonate resin.
  1. Size: 3 inch (76 mm).
  2. Size: 5 inch (127 mm).

### **Part 3 EXECUTION**

#### **3.1 EXAMINATION**

- A. Do not begin installation until substrates have been properly prepared.
- B. If substrate preparation is the responsibility of another installer, notify Architect of unsatisfactory preparation before proceeding.
- C. Field Measurements and Quantity Take Off: A manufacturer-certified technician shall perform on-site field measurements, coordinate design and layout, designate and tag products based on project conditions.

#### **3.2 PREPARATION**

- A. Clean roofing surfaces in accordance with the roofing manufacturer's instructions prior to installation.
- B. Prepare surfaces using the methods recommended by the manufacturer for achieving the best result for each substrate under the project conditions.
  1. For ballasted or built-up roofs, all loose aggregate shall be removed from an area 2 inches (51 mm) outside each base footprint.

#### **3.3 INSTALLATION**

- A. MIRO supports shall be installed as per the product specifications and or project specific submittals.
- B. Install an additional sheet of roofing material, or a MIRO Support Pad beneath the base of each stand.
- C. Place the supports:
  1. Center each stand beneath the component so supports are aligned.
  2. If more than one pipe is being supported, adjust for even weight distribution.
  3. Set pipe in support without dropping or causing any undue impact.
- D. Adjustable Supports: Adjust height of each support to achieve proper height and level before

installing supported item.

1. Level hangers, rollers or struts before installing component.
  2. Make final height adjustments to provide even-distribution of load on all supports.
- E. Fixed Anchor Stanchion Supports: Prior to installation of roof decking, insulation and roof membrane, attach support to roof structure as indicated on drawings.
1. After installation of roof decking, insulation and membrane, install pipe or rooftop mechanical supports used in connection with fixed anchor supports.
  2. Install piping or mechanical units on each support.

### 3.4 FIELD QUALITY CONTROL

- A. When requested by Architect, provide a factory-trained representative of the manufacturer to visit the site while work is in progress to assure that installation complies with design requirements and manufacturer's installation requirements.
- B. After system startup, correct any deficiencies that arise, including but not limited to, improper location or position, improper seating or level on the roof, lack of roof pads, or inadequate operation, as directed by Architect.

### 3.5 PROTECTION

- A. Protect installed products until completion of project.
- B. Touch-up, repair or replace damaged products before Substantial Completion.

END OF SECTION